

Features

Briggs & Stratton Vanguard engine

Premium-grade Vanguard engines are application-engineered to operate in tough conditions.

Low oil protection

In the event there is low-oil pressure, the engine will shut down, which will protect the engine from damage.

Premium Square D circuit breakers

Providing clear and instant identification of a tripped circuit with a Visi-Trip indicator.

Vacuum Fuel Pump

2 feet fuel lift capability.

60 Amp NEMA 14-60 full power plug included

You supply the #4/4 conductor cord, we provide the plug.

100% load tested

You won't find statistical sampling here. We load test every generator before it leaves our facility.

EMERGEN-C VEHICLE MOUNTED

18,000 Surge Watts

15,000 Continuous Watts



NEMA 14-60 60A

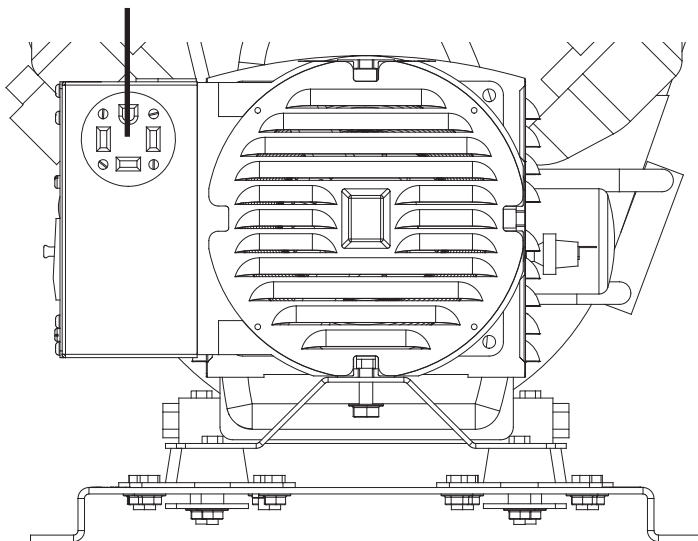

Optional Accessories

Fuel System

Includes 15 gallon composite fuel tank, primer bulb, fuel cap with gauge, carbon canister, fuel line, connectors, and brackets.

Maintenance kit

Keep the engine at its peak performance to ensure the generator will be ready when needed most.

Battery

Premium Interstate Group 26 500 CCA battery for a quick, reliable start-up.

GENERATOR

| | |
|-----------------------------------|------------------|
| SURGE WATTS | 18,000 |
| CONTINUOUS WATTS | 15,000 |
| AMPS @ 240V | 62.5 |
| OUTPUT | 120/240 VAC |
| VOLTAGE REGULATION | CAPACITOR +/-5% |
| MAIN CIRCUIT BREAKER | 60 AMP, 240 VAC |
| BONDED NEUTRAL | YES |
| 120/240 VOLT RECEPTACLES | NEMA 14-60 60AMP |
| GENERATOR WARRANTY ⁽¹⁾ | 2 YRS |

NOTES: (1) For more generator warranty information contact your local WINCO dealer.

FUEL CONSUMPTION

| | |
|-----------|-------------|
| 100% LOAD | 2.69 GAL/HR |
| 75% LOAD | 2.15 GAL/HR |
| 50% LOAD | 1.62 GAL/HR |
| 25% LOAD | 1.21 GAL/HR |
| 0% LOAD | 0.88 GAL/HR |

SHIPPING

| | |
|---------------------|-------------------|
| DIMENSIONS (LxWxH) | 34" x 21.2" x 24" |
| NET WEIGHT | 305 LBS |
| SHIPPING DIMENSIONS | 50" x 27" x 32" |
| SHIP WEIGHT | 326 LBS |
| FREIGHT CLASS | 70 |

ENGINE

| | |
|--|----------------------|
| ENGINE BRAND | BRIGGS & STRATTON |
| ENGINE MODEL | VANGUARD |
| ENGINE STARTER | ELECTRIC |
| ENGINE SPEED | 3600 RPM |
| ENGINE CYLINDERS | V-TWIN |
| DISPLACEMENT/TYPE | 895 CC / OHV |
| LOW OIL PROTECTION | STANDARD |
| RECOMMENDED OIL ⁽¹⁾ | 10W-30 |
| OIL CAPACITY | 2.5 QT |
| dBA AT 7 METERS | 79 |
| FUEL SYSTEM | OPTIONAL |
| HOUR METER | YES |
| MOTOR STARTING (CODE G) ⁽²⁾ | 6 HP |
| EPA APPROVED | YES |
| CARB APPROVED | NO |
| CSA APPROVED | NO |
| BATTERY SIZE ⁽³⁾ | BCI GROUP 26 500 CCA |
| ENGINE WARRANTY ⁽⁴⁾ | 3 YRS COMMERCIAL |

NOTES: (1) The oil recommended is for normal applications. See operator's manual for the recommended oil for your needs. (2) Code G capacitor start motor. (3) Battery not included (4) Contact your local Honda service center for engine warranty assistance.

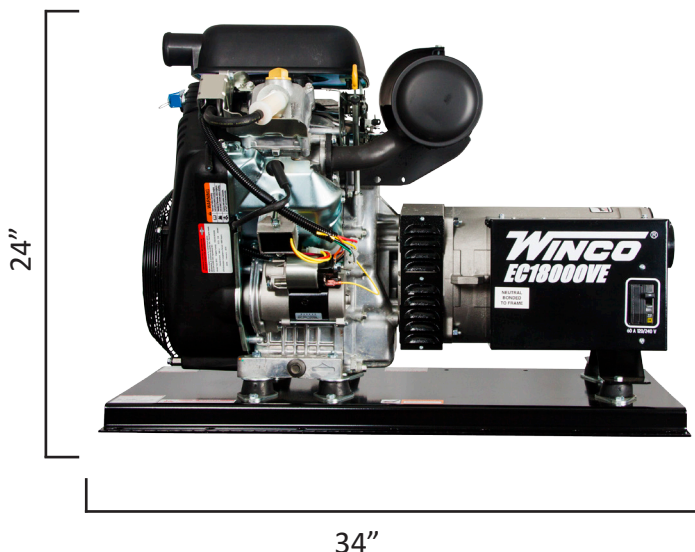

Specifications are subject to change without notice.

225 S. Cordova Ave Le Center MN • 1-800-733-2112 • www.wincogen.com