

DR100F4

LIQUID COOLED DIESEL GENERATOR SET

WINPOWER

Est. 1925

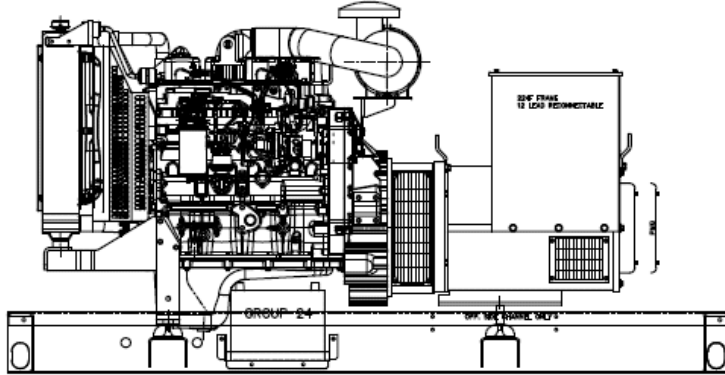

Standby Rating
105kW 60Hz

Powered by ...



N67 TM1

6.7 Liter

Turbocharged Aftercooled

EXPERIENCED DESIGN

- EXPERIENCE IN THE GENERATOR INDUSTRY SINCE 1925
- UL2200 AND CSA LISTED
- DESIGNED FOR LONG LIFE TO MAXIMIZE RETURN ON INVESTMENT
- WELDED AND POWDER COATED STEEL BASE
- ELECTRICIAN FRIENDLY SINGLE COVER CONNECTION POINTS
- LOAD BANK TESTED
- SINGLE STEP 100% LOAD TESTED

ENGINE

- EPA CARB TIER 3 COMPLIANT
- PRECISION ITALIAN MANUFACTURING
- COMPLETE SERVICE NETWORK (INCLUDING MOST CASE AND NEW HOLLAND DEALERS)
- EFFICIENT LOW FUEL CONSUMPTION DESIGN

DSE 7310 CONTROLLER

- GENERATOR PROTECTION AND METERING
- EVENT FAULT LOG RECORDING
- 9 CONFIGURABLE INPUTS (EXPANDABLE TO 24)
- 6 CONFIGURABLE OUTPUTS (EXPANDABLE TO 80)

GENERATOR

- STANDBY RATED
- BRUSHLESS ROTATING FIELD
- WOUND 2/3 PITCH FOR LOW HARMONIC DISTORTION
- CLASS H WINDING INSULATION FOR PEAK PROTECTION
- MEETS BS EN 60034, BS5000, VDE 0530, NEMA MG1-32, ICE34, CSA C22.2-100, AS1359
- SX460 AUTOMATIC VOLTAGE REGULATION STANDARD STEADY STATE VOLTAGE +/- 1.5%
- OPTIONAL PMG WITH 1% OR .5% VOLTAGE REGULATION ISOLATES THE AVR CONTROL CIRCUIT FROM THE EFFECTS OF NON-LINEAR LOADS, REDUCES TRANSIT VOLTAGE DIP DURING HEAVY MOTOR STARTING. BUILT IN OVER-EXCITATION PROTECTION IN CASE OF A SHORT CIRCUIT

ENGINE SPECIFICATIONS

MAKE	FPT
MODEL	N67 TM1
TYPE	DIESEL
KWM @ 1800 RPM-STANDBY	141
GROSS HORSEPOWER-STANDBY	201 HP
INJECTION SYSTEM	DIRECT
SPEED GOVERNOR	MECHANICAL
CYLINDERS	6
TOTAL DISPLACEMENT	6.7L
BORE X STROKE	mm 104 X 132
ASPIRATION	TURBOCHARGED AFTERCOOLED
COMBUSTION AIR REQUIREMENT	410 CFM
COOLING	LIQUID
RADIATOR CAPACITY	3.83 GAL
TOTAL COOLING CAPACITY	6.6 GAL
COOLING AIR REQUIREMENT	12,078 CFM
HOUSING	SAE 3
FLYWHEEL	11½ inches
ROTATION	CCW
LUBE OIL SPEC	API CF-CH4, ACEA E3-E5
LUBE OIL CONSUMPTION	< 0.1% OF FUEL.
OIL & FILTER REPLACEMENT	600 HRS
TOTAL OIL CAPACITY	18 QUARTS
FUEL SPEC	EN 590
EXHAUST OUTLET SIZE @ MUFFLER	5"
ELECTRICAL SYSTEM (NEGATIVE GROUND)	12 VDC
ALTERNATOR (BOSCH)	90 AMPS
STARTER	BOSCH
BATTERY (NOT INCLUDED BCI 31)	900 CCA

ALTERNATOR SPECIFICATIONS

RATING	(125/40°C) STANDBY
TYPE	4 POLE – REVOLVING FIELD
SPEED	1800 rpm
INSULATION SYSTEM	CLASS H
SINGLE PHASE	4 LEAD
THREE PHASE	12 LEAD
STATOR WINDINGS	DOUBLE LAYER CONCENTRIC
PITCH	2/3
WAVEFORM DISTORTION	1.5%
TELEPHONE INTERFERENCE	<2.0%
EFFICIENCY PEAK	~93.5%
COUPLING	FLEXIBLE DISC
BEARINGS (MAINTENANCE FREE)	1
VOLTAGE CONTROL	(SX460 STANDARD) SELF EXCITED
REGULATION	+/- 1.5%
SINGLE PHASE RATING	1.0pf
THREE PHASE RATING	0.8pf

Permanent Magnet Generator Available

If the information that you require is not shown, please contact your dealer.

GENERATOR CONTROLLER

General

Deep Sea digital genset controllers are highly advanced microprocessor controllers. Each model is designed to stand up to the harshest conditions providing timely performance information and safety shutdowns. With so many options it is easy to find a controller flexible enough to meet your application. Some options may require activation through the free interface software or additional accessories. The DSE 7310 is standard.

Feature	DSE7310
Engine Display/Protection	
Engine RPM	X
Low Oil Pressure	X
High Coolant Temperature	X
Low Coolant Level	Optional
Overspeed	X
Underspeed	X
Overcrank	X
Charging Alternator Failure	X
CAN ECU Shutdown	X
Genset Display/Protection	
Voltage (L-N)	X
Voltage (L-L)	X
Overvoltage	X
Undervoltage	X
Frequency	X
Overfrequency	X
Underfrequency	X
Phase Imbalance	Disabled
Amp Display/Shutdown	X
kW, kVa, kVAr, pf Display	X
kWh, kVAh, kVArh Display	X
Generator Phase Sequence	X
Earth Current	Optional
Additional Displays/Protections	
Emergency Stop	X
Fuel Leak/Sender Failure	X
High Fuel Level	Optional
Low Fuel Level	X
Fuel Level	X
Battery Voltage	X
Battery Over/Under Voltage	X
Battery Charger Failure	Optional
Communications	
USB Connectable	X
RS232/RS485	X
NFPA Annunciator	10xDSE2548
Remote Display Panel	3xDSE2510
Ethernet/Modem	Optional
Additional Features	
Audible Alarm	X
Engine Exerciser	X
Maintenance Interval Timer	3 Event
Load Shedding/Dummy	5 Step
Configurable Inputs	9-24w/DSE2130
Configurable Outputs	6-80w/DSE2751
Event Log	250
Alternative Configurations	3
UL/CSA Listed	X

OPERATIONAL DATA



Electrical Output 105kW Standby

Output Voltage – 60Hz	kW	kVa	Amperes	CB Size
120/240, 1-phase, 1.0 pf	100	100	416	400
120/208, 3-phase, 0.8 pf	105	131	364	350
120/240, 3-phase, 0.8 pf	105	131	315	300
277/480, 3-phase, 0.8 pf	115	143	172	175

Consult factory for switchable voltage and 50hz.

Fuel Consumption

100% Load.....	7.71 Gallons/Hr
80% Load.....	6.78 Gallons/Hr
50% Load.....	4.67 Gallons/Hr

Winpower offers two UL142 double wall fuel tank options for this model. This includes removable stub-up end plate as well as leak detection and digital fuel level indication.

NFPA 110 Level 1 Package Option

This option provides a higher state of readiness in accordance with NFPA 110. Option includes a dual rate battery maintenance charger with failure indication, 16-light remote annunciator, low coolant level indication, block heater upgrade that maintains 100°-120°F and enhanced genset controller pre-alarm settings.

Derating Factors

Temperatures > 104°F	3% per 10°F
Altitude	3% per 1000 ft
Prime Power.....	10%
Max Operating Temp.....	50°C/122°F

Engine Block Heater Specifications

- Volts – 120
- Watts – 1000
- Thermostat On/Off - 100°/120°F

Limited Warranty

Winpower warrants its product from material defects for a period of one year or 1000 hrs. FPT warrants the engine for standby generator applications for 60 months or 2000 hours. Contact Winpower for copies of full warranty statements.

Options and Accessories*

Optional Fuel Accessories

- 230 gal UL142 Tank
- 415 gal UL142 Tank
- DOT Trailer w/Integrated Tank

Battery Chargers

- 2 amp (Standard)
- 5 amp w/Fail Contact
- 10 amp w/Fail Contact
- 10 amp NFPA compliant

Enclosure Options

- POWR-PAK (Open skid, no enclosure)
- SOUND-PAK

Controller Options

- DSE 7310 (Standard)
- NFPA 110 Level 1
- 16 Light Remote Annunciator
- Remote Display Panel (DSE 2510)
- Ethernet
- DSE 2130 Input Expansion
- DSE 2751 Output Expansion

Generator Accessories

- Anti-condensation Heater
- PMG
- 12 Lead (Double Delta) Single Phase

Distributed by

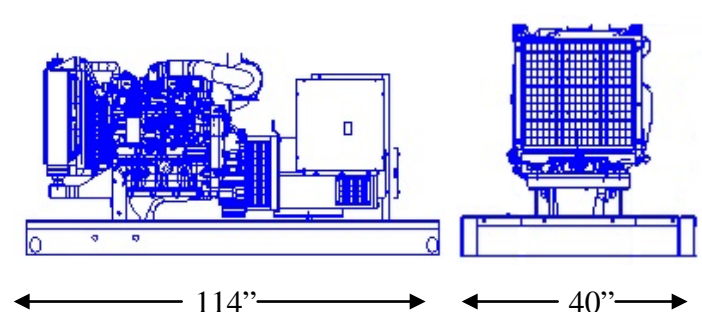

* NOT ALL OPTIONS ARE UL2200 LISTED
 SPECIFICATIONS SUBJECT TO CHANGE WITHOUT NOTICE