

WINCO[®]

DE SERIES GENERATORS

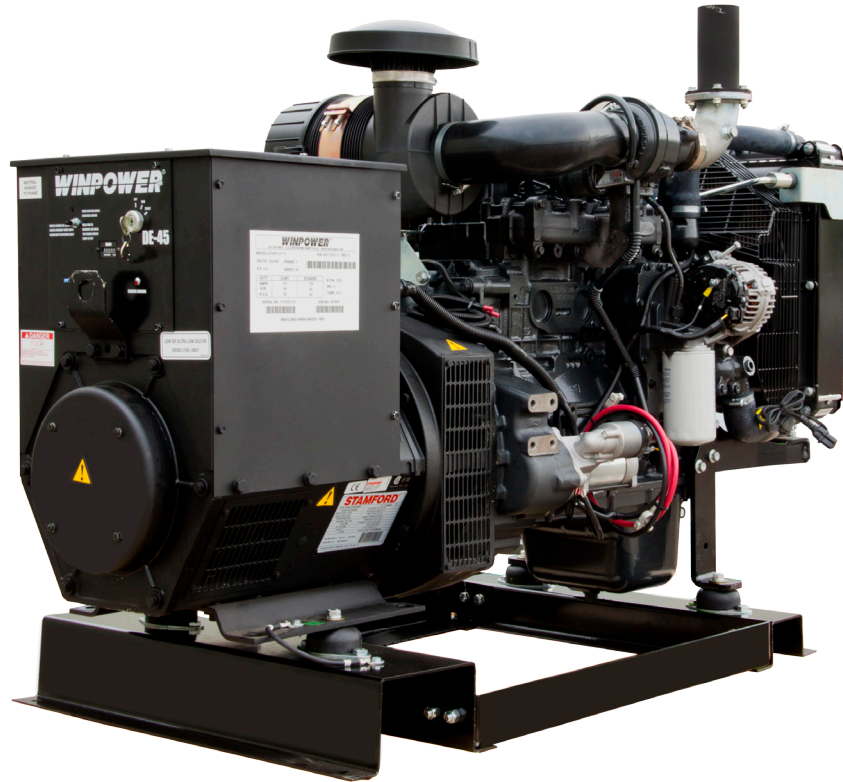

INSTALLATION AND OPERATORS MANUAL

MANUAL KEY START AND DSE4510 ELECTRIC START

WINCO INC. 225 S. CORDOVA AVE. LE CENTER, MN 56057 507-357-6821
SERVICE DEPT. 507-357-6831
www.wincogen.com

TABLE OF CONTENTS

SAVE THESE INSTRUCTIONS

SAFETY

IMPORTANT SAFETY INSTRUCTIONS
ANSI SAFETY DEFINITIONS

TESTING POLICY

SPECIFICATIONS

DE2014
DE45F4
DE65F4
DE90F4

INTRODUCTION

PRODUCT DESCRIPTION

PREPARING THE UNIT

UNPACKING
LIFTING THE GENERATOR SET

INSTALLATION

GENERAL INFORMATION
ENGINE GENERATOR SET MOUNTING
VENTILATION REQUIREMENTS

FUEL INSTALLATION

INSTALLING THE FUEL LINE
LUBRICATION
COOLANT
INSTALLING THE BATTERY

A.C. ELECTRICAL CONNECTIONS

Neutral Lugs
Ground Lug
SERVICING BATTERIES
Generator Circuit Breaker

	ENGINE CONTROL PANEL LAYOUT	12
	MANUAL KEY START	
	INITIAL START UP	
2	STARTING PROCEDURE	
3	DSE4510 ENGINE CONTROLLER	
	MODULE DISPLAY	
	FRONT PANEL CONFIGURATION	13
3	DSE 4510 CONTROLLER	14
4	DEFAULT CODES	14
	DSE4510 ELECTRONIC START CONTROL LAYOUT	
	DSE4510 INITIAL START UP	
	STARTING PROCEDURE	
6	TROUBLE SHOOTING TABLES	15
	CONTROL BOX AC WIRING	16
7	KEY START PANEL SCHEMATIC	16
	DE20 & DE30 ENGINE HARNESS SCHEMATIC	17
7	DE45 & DE65 ENGINE HARNESS SCHEMATIC	17
	4510 ELECTRIC START PANEL	18
	THREE PHASE AC WIRE HIGH AND LOW WYE	18
8	THREE PHASE AC WIRING- DELTA	19
	SINGLE PHASE 311 WINDING	19
	12 MONTH LIMITED WARRANTY	20
10		

SAVE THESE INSTRUCTIONS

This manual contains important instructions that should be followed during installation and maintenance of the generator. Read and understand all instructions in the manual before starting and operating the generator.

USING THIS MANUAL

Congratulations on your choice of a WINCO generator. You have selected a high-quality, precision-engineered generator designed and tested to give you years of satisfactory service.

To get the best performance from your new generator, it is important that you carefully read and follow the operating instructions in this manual.

Should you experience a problem please follow the "Troubleshooting Tables" near the end of this manual. The warranty listed in the manual describes what you can expect from WINCO should you need service assistance in the future.

COPY YOUR MODEL AND SERIAL NUMBER HERE
No other WINCO generator has the same serial number as yours.
If you should ever need to contact us on this unit, it will help us to respond to your needs faster.

MODEL _____

SERIAL NUMBER _____

PURCHASE DATE _____

DEALER NAME _____

DEALER PHONE # _____

SAFETY

IMPORTANT SAFETY INSTRUCTIONS

SAVE THESE INSTRUCTIONS

This manual contains important information that should be understood and followed before the installation, operation and maintenance of the generator. Failure to follow the safety instructions in this manual could result in serious injury or death. Keep this manual available for future reference.

ANSI SAFETY DEFINITIONS

DANGER:

DANGER indicates an imminently hazardous situation which, if not avoided, will result in death or serious injury. This signal word is to be limited to the most extreme situations.

WARNING:

WARNING indicates a potentially hazardous situation which, if not avoided, could result in death or serious injury.

CAUTION:

CAUTION indicates a potentially hazardous situation which, if not avoided, may result in minor or moderate injury. It may be used to alert against unsafe practices.

NOTE: CAUTION is also used on the unit labels and in this manual to indicate a situation that could result in serious damage or destruction of the equipment and possible personal injury.

1. ELECTRIC SHOCK -

The output voltage present in this equipment can cause a fatal electric shock. This equipment must be operated by a responsible person.

- A. Do not allow anyone to operate the generator without proper instruction.

- B. Guard against electric shock.
- C. Avoid contact with live terminals or receptacles.
- D. Use extreme care if operating this unit in rain or snow.
- E. Use only three-prong grounded plugs and extension cords.
- F. Be sure the unit is properly grounded to an external ground rod driven into the earth.

2. FIRE HAZARD -

- A. Keep a fire extinguisher nearby and know its proper use. Fire extinguishers rated ABC by NFPA are appropriate.

3. NOISE HAZARD -

Excessive noise is not only tiring, but continual exposure can lead to loss of hearing.

- A. Use hearing protection when working around this equipment for long periods of time.
- B. Keep your neighbors in mind when permanently installing this equipment.

4. CLEANLINESS -

Keep the generator and surrounding area clean.

- A. Remove all grease, ice, snow or materials that create slippery conditions around the unit.
- B. Remove any rags or other materials that could create a potential fire hazard.
- C. Carefully clean up any gas or oil spills before starting the unit.

5. SERVICING EQUIPMENT -

All service, including the installation or replacement of service parts, **should be performed only by a qualified technician.**

- A. Use only factory approved repair parts.
- B. Do not work on this equipment fatigued.
- C. Use extreme caution when working on electrical components. High output voltages from this equipment can cause serious injury or death.
- D. Installing a generator is not a "do-it-yourself" project. Consult a qualified, licensed electrician or contractor. The installation must comply with all national, state, and local codes.

TESTING POLICY

Before any generator is shipped from the factory, it is fully checked for performance. The generator is loaded to its full capacity, and the voltage, current, and frequency are carefully checked.

Rated output of generator is based on engineering tests of typical units, and is subject to, and limited by, the temperature, altitude, fuel, and other conditions specified by the manufacturer of applicable engines.

SPECIFICATIONS

DE2014

MODEL	DE2014-3	DE-2014-4	DE2014-17	DE2014-18
Generator				
Wattage	20,000	20,000	20,000	20,000
Volts	120/240	120/208	120/240	277/480
Phase	Single	Three	Three	Three
PF	1.0	.80	.80	.80
Amps	83.0	69.5	60.2	30.1
Hertz	60	60	60	60
Engine				
Model	Isuzu 4LE1			
Starting System	12 Volt			
Muffler	Standard			
Fuel Consumption (full load)	1.8 Gal/hr			

Generator Testing Resistance

Model	Stamford PI144E
Winding Group	06 (1ph) 311 (3ph)
Resistances	Ohms
Rotor	0.67
Stator 311	0.296 @ 22°C
Stator 06	0.148 @ 22°C
Exciter Rotor	0.215
Exciter Stator	19.36
Voltage Regulator	AS480

Engine Replacement Parts

Oil Filter (2 req'd)	2992544
Pre-fuel Filter and Water Sep	2992662
Water Sensor	4254020
Fuel Filter Elements	2994048
Air Filter Element	8025818
Alternator Belt	500341810
Alternator	500315943
Starter Motor Assembly	99486046
Upper Radiator Hose	8040980
Lower Radiator Hose	

Engine Fluid Specifications

Fuel	ASTM D-975 -1D or 2D EN590 or equivalent
	See engine manual for additional fuel types and specifications
Oil Type	See Lubrication section in this manual
Oil Capacity	8.6 Quarts
Cooling System	50/50 mix

DE3014

MODEL	DE3014-3	DE-3014-4	DE3014-17	DE3014-18
Generator				
Wattage	29,000	30,000	30,000	30,000
Volts	120/240	120/208	120/240	277/480
Phase	Single	Three	Three	Three
PF	1.0	.80	.80	.80
Amps	120	104	90	45
Hertz	60	60	60	60
Engine				
Model	Isuzu 4LE1T Turbocharged			
Starting System	12 Volt			
Muffler	Standard			
Fuel Consumption (full load)	2.6 Gal/hr			

Generator Testing Resistance

Model	Stamford PI144H
Winding Group	06 (1ph) 311 (3ph)
Resistances	Ohms
Rotor	0.89
Stator 311	0.179 @ 22°C
Stator 06	0.060 @ 22°C
Exciter Rotor	0.21
Exciter Stator	22.9
Voltage Regulator	AS480

Engine Replacement Parts

Oil Filter (2 req'd)	2992544
Pre-fuel Filter and Water Sep	2992662
Water Sensor	4254020
Fuel Filter Elements	2994048
Air Filter Element	8025818
Alternator Belt	500341810
Alternator	500315943
Starter Motor Assembly	99486046
Upper Radiator Hose	8040980
Lower Radiator Hose	

Engine Fluid Specifications

Fuel	ASTM D-975 -1D or 2D EN590 or equivalent
	See engine manual for additional fuel types and specifications
Oil Type	See Lubrication section in this manual
Oil Capacity	8.6 Quarts
Cooling System	50/50 mix

DE45F4

MODEL	DE45F4-3	DE-45F4-4	DE45F4-17	DE45F4-18
Generator				
Wattage	40,000	45,000	45,000	45,000
Volts	120/240	120/208	120/240	277/480
Phase	Single	Three	Three	Three
PF	1.0	.80	.80	.80
Amps	166	156	135	68
Hertz	60	60	60	60
Engine				
Model	FPT N45SM1 Turbocharged			
Starting System	12 Volt			
Muffler	Standard			
Fuel Consumption (full load)	4.09 Gal/hr			

Generator Testing Resistance

Model	Stamford UC1224D
Winding Group	311
Resistances	Ohms
Rotor	0.64
Stator	0.129 @ 22°C
Exciter Rotor	0.142
Exciter Stator	21.0
Voltage Regulator	SX460

Engine Replacement Parts

Oil Filter	2992242
Fuel Filter Elements	50410784
Air Filter Element	8041642
Alternator Belt	504013617
Alternator	504225814
Starter Motor Assembly	504031929
Upper Radiator Hose	8050892
Lower Radiator Hose	8050893

Engine Fluid Specifications

Fuel	ASTM D-975 -1D or 2D EN590 or equivalent
	See engine manual for additional fuel types and specifications
Oil Type	See Lubrication section in this manual
Oil Capacity	13.5 Quarts
Cooling System	50/50 mix

DE65F4

MODEL	DE65F4-3	DE-65F4-4	DE65F4-17	DE65F4-18
Generator				
Wattage	55,000	62,000	62,000	62,000
Volts	120/240	120/208	120/240	277/480
Phase	Single	Three	Three	Three
PF	1.0	.80	.80	.80
Amps	229	215	186	93
Hertz	60	60	60	60
Engine				
Model	FPT N45SM2 Turbocharged			
Starting System	12 Volt			
Muffler	Standard			
Fuel Consumption (full load)	4.57 Gal/hr			

Generator Testing Resistance

Model	Stamford UC1224F
Winding Group	311
Resistances	Ohms
Rotor	0.83
Stator	0.065 @ 22°C
Exciter Rotor	.078
Exciter Stator	20.0
Voltage Regulator	SX460

Engine Replacement Parts

Oil Filter	2992242
Fuel Filter Elements	50410784
Air Filter Element	8041642
Alternator Belt	504013617
Alternator	504225814
Starter Motor Assembly	504031929
Upper Radiator Hose	8050892
Lower Radiator Hose	8050893

Engine Fluid Specifications

Fuel	ASTM D-975 -1D or 2D EN590 or equivalent
	See engine manual for additional fuel types and specifications
Oil Type	See Lubrication section in this manual
Oil Capacity	13.5 Quarts
Cooling System	50/50 mix

DE90F4

MODEL	DE90F4-3	DE-90F4-4	DE90F4-17	DE90F4-18
Generator				
Wattage	86,000	90,000	90,000	90,000
Volts	120/240	120/208	120/240	277/480
Phase	Single	Three	Three	Three
PF	1.0	.80	.80	.80
Amps	358	312	270	135
Hertz	60	60	60	60
Engine				
Model	FPT N45TM2 Turbocharged After-Cooled			
Starting System	12 Volt			
Muffler	Standard			
Fuel Consumption (full load)	6.94 Gal/hr			

Generator Testing Resistance

Model	Stamford UC1274C
Winding Group	06 (1ph) 311 (3PH)
Resistances	Ohms
Rotor	1.12
Stator 311	0.059 @ 22°C
Stator 06	0.022 @ 22°C
Exciter Rotor	0.091
Exciter Stator	20.0
Voltage Regulator	SX460

Engine Replacement Parts

Oil Filter	2992242
Fuel Filter Elements	50410784
Air Filter Element	8041322
Alternator Belt	504013617
Alternator	504225814
Starter Motor Assembly	504031929
Radiator Hose Adapter (2)	8036102
Upper Radiator Hose	4863960
Lower Radiator Hose	98433199

Engine Fluid Specifications

Fuel	ASTM D-975 -1D or 2D EN590 or equivalent
	See engine manual for additional fuel types and specifications
Oil Type	See Lubrication section in this manual
Oil Capacity	13.5 Quarts
Cooling System	50/50 mix

INTRODUCTION

PRODUCT DESCRIPTION

The engine-generator set consists of a multi-cylinder, liquid-cooled engine nominally operating at 1800 RPM. The generator frequency regulation is maintained by the engine governor to within +/- 1.5 Hertz from no load to rated load for standard mechanical governors. The generator is connected to the engine flywheel via flexible drive disks. The generator set is skid mounted with isolation mounts between the engine and base on all units.

NOTICE:

A Customer supplied 12 Volt battery is required to complete the installation. Battery requirements are listed later under the battery installation section.

These engine-generator sets come standard with a manual key start system. This key start system utilizes a safety latching relay that shuts the unit down if the oil pressure gets low or water temperature gets too high. **The safety latching relay must be depressed during cranking.** The optional DSE4510 digital controller is available and electronically starts the generator set. The DSE4510 will electronically display useful engine and generator performance information. The controller monitors critical operating parameters and will shut the generator down to protect the equipment from damage.

GENERATOR SET:

Every WINPOWER generator set has its own unique identity data plate. This data plate identifies the complete unit model number, the system serial number, and has links to the individual components that form the generator set in our factory records. Several of the major components also have their own individual data plates providing additional information to document build data for warranty and replacements parts. Be sure to have the main WINPOWER unit data plate information recorded inside the front cover of this manual for future reference and for identification whenever requesting field or factory assistance. Primary fields needed for assistance are complete model number and serial number.

ENGINE:

This manual covers specific operation of the combined engine generator set. The basic engine information provided in this manual is not suitable for all operating conditions. Refer to the engine operators manual for more detailed operation and maintenance information.

CAUTION: EQUIPMENT DAMAGE:

Be sure to check the engine oil level frequently as specified in the engine manual.

The engine manufacturer has established an excellent worldwide engine service organization; engine service is available from a nearby authorized dealer or distributor. Go to the WINCO website for a list of engine dealers (http://wincogen.com/Engine_Support) or contact the WINCO Service Department.

The rated power of each engine-generator is limited by the temperature, altitude, and all other ambient conditions specified by the engine manufacturer. Engine power may decrease 3½% for each 1000 feet above sea level, and will decrease an additional 1% for each 10 degrees Fahrenheit above 60° Fahrenheit. Units should not be operated in ambient temperature greater than 125° Fahrenheit.

GENERATOR:

WINPOWER generator sets use brushless, AVR (Auto-Voltage Regulator) controlled broad-range generator ends. The generator converts rotational mechanical energy into electrical energy. These WINPOWER units are equipped with generators manufactured by Cummins Stamford. Each generator 'end' has its own data tag. A unique serial number is on the data plate and the data label is affixed to the main frame on the generator on the left side.

PREPARING THE UNIT

UNPACKING

1. As you receive your unit, it is critical to check it for any damage. If any damage is noted, it is always easiest to refuse the shipment and let WINCO take care of the freight claim. If you sign for the unit, the transfer of the ownership requires that you file the freight claim

2. Before proceeding with the preparations of your new generator for operation, take a couple of minutes to ensure the unit you have received is the correct model and review the specification pages in this manual to ensure that this unit meets your job requirements.

CAUTION: EQUIPMENT DAMAGE:

These units are shipped with oil and a 50/50 mix of coolant. Be sure to check all fluid levels before operating. See engine manufacturer's instruction manual for recommended oil requirements before initial starting.

Once generator set is on-site:

1. Carefully remove the crate.
2. After inspecting the engine-generator for external, physical damage, locate and check the following items packed with the unit:
 - a. Installation and Operator's Manual.
 - b. Engine manufacturer's instruction manual.
 - c. Battery hold-down brackets & hardware.
 - d. Unit components or accessory items shipped loose for on-site installation.
 - e. Optional accessories.
3. Remove main frame hold-down bolts.
4. Unit can now be lifted from shipping rails.

LIFTING THE GENERATOR SET

NOTICE: PERSONAL INJURY:

To prevent injury to persons or equipment, observe the following guidelines when lifting the generator:

Due to the different designs, configurations, options, weights, site conditions, and available material handling equipment, specific lifting instructions are not provided for each individual generator set model. General guidelines provided are applicable to the entire generator line. It is the responsibility of the installing party to follow the lifting equipment's operator's manual to prevent injury to personnel and damage to the generator. Smaller generator sets may not require use of overhead lifting equipment and may be placed on the pad with basic material handling equipment, i.e. a forklift.

CAUTION:

Do not attempt to lift the generator set by the means of the lifting eyes on the engine or generator end. These lifting points are only for the use during the manufacturing process and are designed for lifting of the individual generator set components.

WARNING:

NEVER attempt to lift the fuel tank filled with fuel. Sloshing of the fuel can cause a shift in the balance of the fuel tank, making for a DANGEROUS, unbalanced lifting load. If the generator was shipped on the fuel tank, use the lifting points located on the fuel tank to move the entire generator set into place. DO NOT PLACE FUEL IN THE TANK PRIOR TO LIFTING.

INSTALLATION

WARNING: PERSONAL INJURY:

Before proceeding with the installation, be sure the engine control is in the "stop" position. Also, be sure the generator MLCB (main line circuit breaker) is in the "off" position and the unit starting battery is disconnected.

GENERAL INFORMATION

This series of engine-generator sets are designed and built as open power units, meaning no weather protection has been provided. These units must be installed inside of an enclosure that will provide proper protection from the elements.

Before beginning the installation process, recheck the voltage, phase, and amperage rating of the generator set. Be certain it can handle the intended load and are compatible with the intended loads. Plans for installation should be prepared with proper attention to mechanical and electrical engineering detail to assure a satisfactory system installation. The installation must comply with all national, state, and local codes.

The information in this manual is offered only as a guide to finalizing your installation plans.

NOTICE:

For full service switching of the entire load, the ATS must be 'SE' (Service Entrance) rated or must have a properly rated fusible disconnect installed before the ATS to protect the contacts.

ENGINE GENERATOR SET MOUNTING

The unit's main frame must be bolted solidly to a solid base. The engine-generator is mounted on channels which are attached with special shock mounts to the main frame. This allows the engine-generator free movement without affecting the base or surrounding equipment.

WARNING: EQUIPMENT DAMAGE:

Never mount these engine-generator sets to a wooden base/structure. Over time, the wood will deteriorate and the unit mountings will come loose. These units must be mounted to a steel or concrete base.

The unit should be mounted to allow ample working room around it. A general rule to follow is five (5) feet of clearance from flammable surfaces. But sufficient access must be provided for servicing the equipment.

VENTILATION REQUIREMENTS

WARNING: EQUIPMENT DAMAGE:

It is the installer's responsibility to ensure that there is sufficient cooling air available to prevent the engine and generator from over heating. Damage caused by overheating is not covered by warranty.

Providing proper air movement during your installation planning is absolutely essential. You will need to provide a fresh air inlet as well as a hot air outlet (to the outside of protection housing) for proper engine performance. These engine-generator sets are equipped with unit mount radiators and the engine is equipped with a pusher type fan. The hot air from the face of the radiator must be ducted out of the enclosure to ensure proper cooling. Failing to do so will allow the hot air to recirculate around the radiator causing the engine to overheat, resulting in an engine shutdown. If louvers are used in front of the hot air duct to protect the unit from outside weather, the louvers should be 1½ times as large as the area of the radiator face to prevent back pressure. In addition to a hot air discharge, you must plan a fresh air intake opposite the radiator discharge. These fresh air inlets should also be 1½ to 2 times larger than the radiator face. The extra air inlet area is required to minimize restriction and to provide combustion air for the engine. Do not block fresh air intakes with other equipment as this will result in insufficient air flow to the engine for cooling. Installing them opposite the hot air discharge will allow a sweeping flow of cooling air across the engine, preventing hot spots.

FUEL INSTALLATION

The fuel supply should be as close to the engine as possible. This will reduce the installation cost of fuel runs and minimize line losses. The diesel fuel supply should be no more than 3 feet below the fuel inlet pump. If your fuel supply is lower than 3 feet, you may have to install an additional lift pump to bring the fuel up to the mechanical fuel pump on the engine.

The information in this manual is offered to assist you in providing the proper fuel for your engine. However, this information is only provided to inform you of the engine's requirements and assist in making

you aware of the decisions you must make. In no case should the instructions or information provided be interpreted to conflict with any local, state, or national codes. If in doubt, always consult your local fire marshal or fuel supplier.

INSTALLING THE FUEL LINE

Engine-generator sets are properly adjusted before they leave the factory. Connecting a fuel supply with adequate supply volume is critical to reliable operation. Diesel units with optional base mounted fuel tanks are pre-plumbed to the mechanical fuel pump on the engine.

Open skid mounted diesel units are often supplied with capped inlet and return lines. The use of a suitable customer supplied flexible fuel lines is essential between the engine and fuel supply to provide a vibration break between your fuel supply and the engine.

WARNING: FIRE DANGER:

Connecting rigid fuel line (i.e. steel or copper line) directly to the inlet fuel filter or fuel pump may cause the fuel line to crack during operation creating a serious fire hazard.

DE20 FUEL CONNECTIONS



FUEL INLET CONNECTION



FUEL RETURN LINE CONNECTION

DE30 FUEL CONNECTIONS

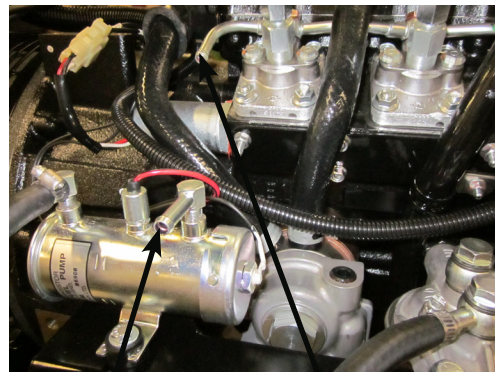

FUEL INLET CONNECTION

FUEL RETURN LINE CONNECTION

DE45-90 FUEL CONNECTIONS

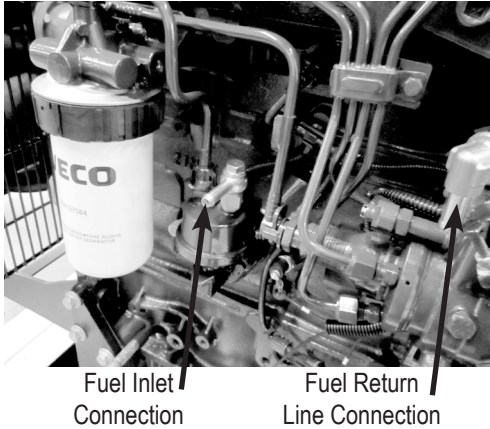

LUBRICATION

Before starting the engine, check the oil level in the crankcase. If it is low, refill to the full mark with the proper weight/grade of oil as recommended by the engine manufacturer's maintenance instructions. The necessity of using the correct oil, and keeping the crankcase full, cannot be over emphasized. Failure to use the proper oil and keep the crankcase properly filled will cause excessive engine wear and shorten its useful life.

ISUZU Oil Viscosity Table
Use API CC or CD

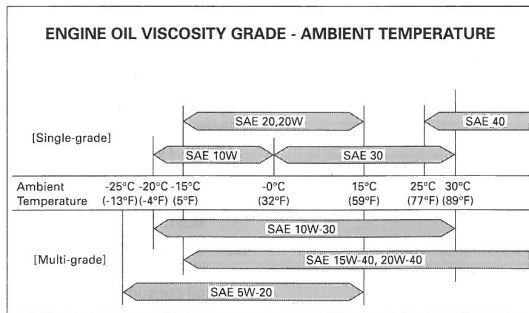

Fiat Oil Viscosity Table
Use API CF of CH

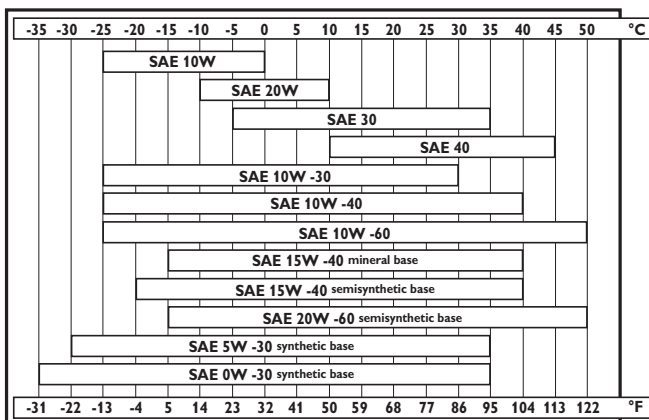

COOLANT

Before starting the engine, check the coolant level in the radiator. If it is low, refill as specified in the engine manufacturer's maintenance instructions. The radiator should be filled to about 1 inch below the filler neck. For additional information on engine coolant requirements, see engine manufacturer's maintenance instructions.

INSTALLING THE BATTERY

CAUTION:

In the following battery installation procedure, check to be sure the engine control is in the "stop" position. This should be your last step before initial start-up.

A customer supplied 12 Volt battery is required to complete the installation. Installation of the highest CCA rated battery, within the correct BCI group, will increase cold weather starting performance.

BATTERY REQUIREMENTS

Model	Voltage	BCI Group	Min. CCA Rating
DE20I4	12	24	650
DE30I4	12	24	650
DE45F4	12	24	650
DE65F4	12	24	650
DE90F4	12	31	900

WARNING: EQUIPMENT DAMAGE:

All of these units are 12 Volt and they are all negative ground. Permanent damage will occur if they are connected to a 24 Volt system or a positive ground system. If you are using the truck batteries to start these units, you may have to disable the charging system to keep it from interfering with the vehicle charging system.

Installation and servicing of batteries must only be performed or supervised by personnel knowledgeable of batteries and the required precautions. Keep unauthorized personnel away from batteries.

When installing or replacing batteries, use the proper group/size starting battery. The battery should be a maintenance-free lead acid design. Deep cycle batteries will not work for this application.

CAUTION: PERSONAL DANGER:

NEVER dispose a battery in a fire. The battery is capable of exploding.

DO NOT open or mutilate the battery. Released electrolyte is known to be harmful to the skin and eyes and to be very toxic.

These engine-generator sets are all NEGATIVE ground. Be very careful not to connect the battery in reverse polarity, as this may short circuit the battery charging system on the engine.

CAUTION:

A battery presents a risk of electrical shock and high short circuit current. The following precautions must be observed when working with batteries:

1. Remove watches, rings, and other metal objects.
2. Use tools with insulated handles.
3. Check both the battery cable ends and the battery posts to be sure they are free of corrosion.
4. Always connect the battery positive cable first and then connect the battery negative cable. When removing the battery cables from the battery, reverse the procedure, disconnect the negative first and then the positive cable.
5. Be sure all connections are tight and coat the terminals and cable ends with dielectric grease.

WARNING:

The electrolyte is diluted sulfuric acid that is harmful to the skin and eyes. It is electrically conductive and corrosive. The following precautions must always be taken.

1. Always wear full eye protection and protective clothing.
2. Where electrolyte contacts skin, wash off immediately with water.
3. If electrolyte contacts the eyes, flush thoroughly and immediately with water and seek immediate medical attention
4. Spilled electrolyte is to be washed down with an acid neutralizing agent. A common practice is to use a solution of one pound of bicarbonate of soda (baking soda) to one gallon of water. The bicarbonate of soda solution is to be added until the evidence of reaction (foaming) has ceased. The resulting liquid is to be flushed with water and the area dried.

DANGER: EXPLOSIVE FIRE RISK:

1. Never smoke when near batteries.
2. Do not cause a flame or spark in the battery area.
3. Always discharge static electricity from your body before touching batteries by first touching a ground metal surface.

SERVICING BATTERIES

Batteries used on these units may, over time, lose water. This is especially true if you are using a trickle charger to maintain your battery. When refilling the battery with water, use only distilled water. Tap water will shorten the service life of the battery.

Never fill the battery above the fill line. Over filling above the upper level line may cause the electrolyte to overflow, resulting in corrosion to the engine or nearby parts. Immediately wash off any spilled electrolyte following the procedure above.

NOTE: Always make sure that a new battery is fully charged before installing it on a generator set. Failure to do so can cause damage to the engine control module in the generator set.

All connections must be clean and tight. Check the electrolyte in the battery periodically to be sure it is above the plates. Never allow the battery to remain in a discharged condition.

A.C. ELECTRICAL CONNECTIONS

NOTICE: CLASS 1 WIRING METHODS ARE TO BE USED FOR ALL FIELD WIRING CONNECTIONS TO TERMINALS OF A CLASS 2 CIRCUIT

NOTE: The symbol  always indicates ground where shown. All wiring must be completed in accordance with the National Electric Code as well as any state and local codes.

You must pay particular attention to wire size requirement for the amperage of service you are dealing with. The table below provides you guidance on wire sizing based on both wire type and amperage. **Wire amperages have been derated for 40° C ambient temperatures operation.**

WARNING:

A mainline circuit breaker has been provided inside the generator housing. During all wiring installations, make sure the breaker is in the OFF position and the generator start battery is disconnected.

NEUTRAL LUGS

Each DE unit comes with a neutral lug from the factory to provide a connection point from the generator to the transfer switch or load distribution center. **The generator ships from the factory with a bonded neutral.**

Model	Lug AMP	Wire Capability	Torque
DE20	100	#12 AWG to #1/10 AWG	50 in. lbs.
DE30 - DE90	225	#4 AWG to 300 MCM	250 in. lbs.

GROUND LUG

Ground lugs are provided to connect to the distribution center. **The Generator ships from the factory with a bonded neutral.**

Model	Wire Capability	Torque
DE20 - DE30	#10 AWG to 2/0 AWG	200 in. lbs.
DE45 - DE90	#6 AWG to 300 MCM	250 in. lbs.

WARNING: PERSONAL DANGER:

These units are shipped with a NEUTRAL TO GROUND BOND INSTALLED. If your system already has a neutral to ground bond, then you must run a separate ground lead to that location and UNBOND THE JUMPER IN THE CONNECTION PANEL. For additional information, refer to the current National Electrical Code on grounding.

WARNING: EQUIPMENT DAMAGE:

When installing a three phase 240 Volt system, be sure you know which lead is high voltage 'wild' leg (208 Volt to neutral). The generator normally carries the high voltage on the G2 lead.

GENERATOR CIRCUIT BREAKER

This circuit breaker provides overload protection for the generator. Your power feeds from the load panel will connect to the open lugs on the circuit breaker. The generator power feeds have already been wired into one set of the lugs.

The following table gives you the circuit breaker size, lug wire sizes and torque specifications. See actual breaker for additional information and restrictions.

kW	Voltage	PH	AMP	Wire Capability	Lug Torque
20	120/240	1	85	#12 AWG - 2/0 AWG	50 in lbs
20	120/208	3	70	#12 AWG - 2/0 AWG	50 in lbs
20	120/240	3	70	#12 AWG - 2/0 AWG	50 in lbs
20	277/480	3	30	#14 AWG - #1/0 AWG	80 in lbs

30	120/240	1	125	#12 AWG - 2/0 AWG	50 in lbs
30	120/208	3	100	#12 AWG - 2/0 AWG	50 in lbs
30	120/240	3	100	#12 AWG - 2/0 AWG	50 in lbs
30	277/480	3	45	#14 AWG - #1/0 AWG	80 in lbs

45	120/240	1	175	#4 AWG - 300 MCM	250 in lbs
45	120/208	3	150	#4 AWG - 300 MCM	250 in lbs
45	120/240	3	750	#4 AWG - 300 MCM	250 in lbs
45	277/480	3	100	#14 AWG - #1/0 AWG	80 in lbs

65	120/240	1	250	#1 AWG - 600 MCM	375 in lbs
65	120/208	3	225	#4 AWG - 300 MCM	250 in lbs
65	120/240	3	225	#4 AWG - 300 MCM	250 in lbs
65	277/480	3	100	#14 AWG - #1/0 AWG	120 in lbs

90	120/240	1	350	#1 AWG - 600 MCM	375 in lbs
90	120/208	3	300	#1 AWG - 600 MCM	375 in lbs
90	120/240	3	300	#1 AWG - 600 MCM	375 in lbs
90	277/480	3	125	#14 AWG - #1/0 AWG	120 in lbs

For additional conductor sizes between the generator and the load. Based on wire type and temperature rating. Wire has been derated for 40°C ambient temperature.

kW	Voltage	PH	CB AMP	Wire Temperature Rating			
				Cu Conductor		Al Conductor	
				75°C	90°C	75°C	90°C
20	120/240	1	85	#3 AWG	#4 AWG	#1 AWG	#2 AWG
20	120/208	3	70	#4 AWG	#6 AWG	#3 AWG	#4 AWG
20	120/240	3	70	#4 AWG	#6 AWG	#3 AWG	#4 AWG
20	277/480	3	30	#8 AWG	#8 AWG	#8 AWG	#8 AWG

kW	Voltage	PH	CB AMP	Wire Temperature Rating			
				Cu Conductor		Al Conductor	
				75°C	90°C	75°C	90°C
30	120/240	1	125	1/0 AWG	#1 AWG	3/0 AWG	2/0 AWG
30	120/208	3	100	#2 AWG	#3 AWG	1/0 AWG	#1 AWG
30	120/240	3	100	#2 AWG	#3 AWG	1/0 AWG	#1 AWG
30	277/480	3	45	#6 AWG	#8 AWG	#4 AWG	#6 AWG

kW	Voltage	PH	CB AMP	Wire Temperature Rating			
				Cu Conductor		Al Conductor	
				75°C	90°C	75°C	90°C
45	120/240	1	175	3/0 AWG	2/0 AWG	250 MCM	4/0 AWG
45	120/208	3	150	2/0 AWG	1/0 AWG	3/0 AWG	2/0 AWG
45	120/240	3	150	2/0 AWG	1/0 AWG	3/0 AWG	2/0 AWG
45	277/480	3	70	#4 AWG	#4 AWG	#2 AWG	#3 AWG

kW	Voltage	PH	CB AMP	Wire Temperature Rating			
				Cu Conductor		Al Conductor	
				75°C	90°C	75°C	90°C
65	120/240	1	250	300 MCM	250 MCM	500 MCM	350 MCM
65	120/208	3	225	250 MCM	4/0 AWG	400 MCM	300 MCM
65	120/240	3	225	250 MCM	4/0 AWG	400 MCM	300 MCM
65	277/480	3	100	#2 AWG	# AWG	1/0 AWG	#1 AWG

kW	Voltage	PH	CB AMP	Wire Temperature Rating			
				Cu Conductor		Al Conductor	
				75°C	90°C	75°C	90°C
90	120/240	1	350	600 MCM	500 MCM	(2) 250	600 MCM
90	120/208	3	300	500 MCM	350 MCM	(2) 4/0	500 MCM
90	120/240	3	300	500 MCM	350 MCM	(2) 4/0	500 MCM
90	277/480	3	125	1/0 AWG	#1 AWG	3/0 AWG	2/0 AWG

For additional information on wire sizing refer to table 310-16 of the National Electrical Code ANSI/NFPA 70.

ENGINE CONTROL PANEL LAYOUT

MANUAL KEY START

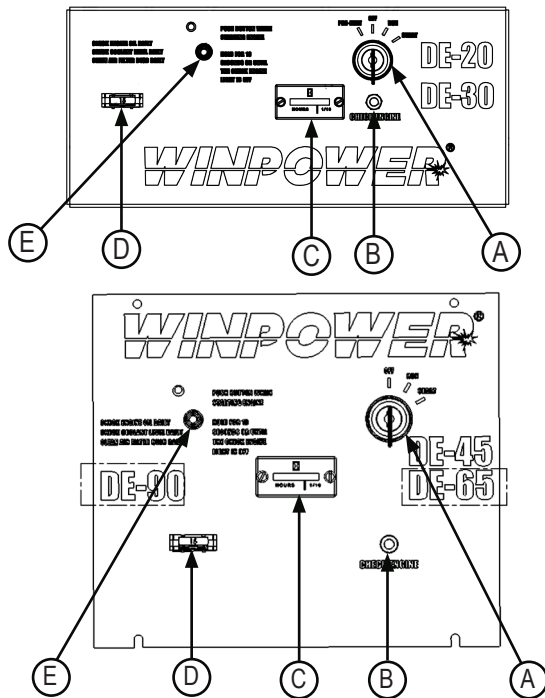

A. Four position start switch

1. Preheat - This position is used on the DE20 and DE30 only. With the switch in this position the glow plugs on the engine are activated.
2. Off - In this position all power to the engine is turned off and the engine is stopped.
3. Run - With the switch in this position the fuel solenoid and the fuel pump on the engine are activated. A 12 Volt signal is also being sent to the Voltage regulator on the engine alternator to activate it.
4. Start - This position on the switch will activate the starter on the engine to start it.

B. Check engine light

This light will come on when the low oil pressure switch or the high water temperature sensor come on when you go to start the engine. This will also come on when you go to start the engine. This light will also come on when you go to start the engine and stay on until the engine has built sufficient oil pressure to open the low oil pressure switch.

C. Running the meter

This meter records the actual hours of the engine operation.

D. 25 Amp fuse

This fuse protects all the DC wiring in the engine control panel and on the engine. If this fuse is blown, nothing will work on the engine.

E. Safety latching relay

This safety latching relay provides the 12 Volt DC power to the fuel solenoid and the engine alternator field circuit during normal operation. If the system experiences a low oil pressure fault or a high water temperature fault, this relay will trip, disconnecting the fuel solenoid

and shutting down the engine. When tripped, the button on the panel will extend out about 1 inch. This button must also be held in during starting until the check engine light goes out.

INITIAL START UP

MANUAL KEY START

Use the following check list to verify correct installation before starting the engine.

- Engine oil. Fill as required with proper grade/qty.
- Engine coolant. Fill as required with proper mixture.
- Unit mounting base properly bolted down.
- Clearance for service and maintenance on all sides.
- Proper fuel line material and size.
- All fuel line connections tight.
- Battery connections clean and tight
- Battery fully charged.
- All AC and DC wiring installed and properly protected.

After completing the previous checklist, the engine-generator set is ready for the initial start-up test.

STARTING PROCEDURE

1. Rotate start switch (A) to the preheat position and hold for 10 seconds. NOTE: This step applies to the DE20 & DE30 ONLY.
2. Rotate the start switch (A) to the Run position. Then while depressing the Safety Latching Relay button (E) rotate the switch to the Start position. At this point the starter should engage and the unit will start.
3. As the unit starts, release the Start Switch and it will return to the run position. You must continue to depress the Safety Latching Relay button until the Check Engine light goes out. When this light goes out, it indicates that the engine has built sufficient oil pressure to operate properly and the high coolant temperature has not been exceeded.

WARNING: EQUIPMENT DAMAGE:

Do not depress the safety latching relay button for over 10 seconds. If the light has not gone out in 10 seconds, it indicates that either the engine has not built oil pressure or the coolant temperature has exceeded the allowable maximum.

4. After the engine is up to and running, the circuit breaker can be closed to power your loads. During periods of very cold operation, it is best to let the engine warm up for a few minutes before applying load.

5. When stopping the unit, it is best to turn off all of the loads before turning the Start Switch to the off position. This prevents your loads from getting low Voltage while still running during unit shutdown. If for any reason during operation the oil pressure should drop below

the allowable level the Safety Latching Relay button will pop out and the unit will shutdown. You will also get a check engine light at this time. If you find the unit stopped with the relay button popped out, it could have been caused by either low oil pressure or high water temperature.

DSE4510 ENGINE CONTROLLER

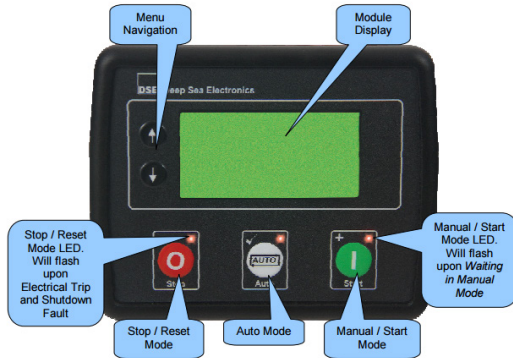

	STOP/RESET (red button) - This button places the module into its Stop/Reset mode. This will clear any alarm conditions for which the triggering criteria have been removed. The fuel supply de-energizes and the engine comes to a standstill. Should a remote start signal be present while operating in this mode, a remote start WILL NOT occur.
	AUTO (white button) - This button places the module into its Automatic mode. This mode allows the module to control the function of the generator automatically. The module will monitor the remote start input and once a start request is made, the set will be automatically started and placed on load. The module will then wait until the next start event.
	START (green button) - Pressing this button from STOP/RESET will start the engine and run the load.
	MENU NAVIGATION - Used for navigating the instrumentation, event log, and configuration screens.

PROTECTIONS

When an alarm is present, the common alarm LED if configures will illuminate. The LCD display will show an icon to indicate the failure.

WARNINGS

Warnings are non-critical alarm conditions and do not affect the operation of the generator system, they serve to draw the operator's attention to an undesirable condition. Warning alarms are self-resetting when the fault condition is removed. The icon will appear steady in they display.

SHUTDOWN

Shutdowns are critical alarm conditions that stop the engine and draw the operator's attention to an undesirable condition. Shutdown alarms are latching. The fault must be removed and the STOP/RESET button pressed to reset the module. The icon will appear flashing in the display.

Example of DSE home page display

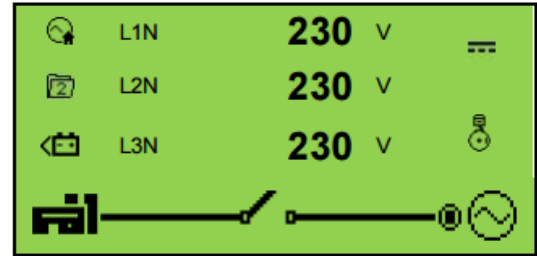

FRONT PANEL CONFIGURATION

1. Press the and the buttons together to enter the editor mode.
2. Press the or navigation buttons to cycle through the front panel editor to select the required page in the configuration tables.
3. Press the to select the next parameter or to select the previous parameter within the current page.
4. When viewing the parameter to be edited, press the button, the value begins to flash.
5. Press the or buttons to adjust the value to the required setting.
6. Press the button to save the current value, the value ceases flashing.
7. Press the button to save and exit the editor, the configuration icon is removed from the display.

NOTES:

Pressing ans holding the or buttons will give auto-repeat functionality. Values can be changed quickly by holding the buttons for a prolonged period of time.

The editor automatically exits after 5 minutes of inactivity to ensure security.

















The PIN number is not set by WINCO when the module leaves the factory. If the code has been 'lost' or 'forgotten', the module must be returned to the DSE factory to have the module removed. A charge will be made for this procedure.







NB - This procedure cannot be performed away from the factory.

The PIN number is automatically reset when the editor is exited (manually or automatically) to ensure security.

DSE 4510 CONTROLLER

DEFAULT CODES

	Auxiliary Inputs - Auxiliary inputs can be be user configured and will display the message as written by the user.
	Fail to Start -The engine has not fired after the preset number of start attempts.
	Low Oil Pressure - The module detects that the engine oil pressure has fallen below the low oil pressure pre-alarm setting level after the Safety On timer has expired.
	Engine High Oil Temperature - The module detects that the engine oil temperature has exceeded the high engine temperature pre-alarm setting level after the Safety On timer has expired.
	Underspeed - The engine speed has fallen below the underspeed pre-alarm setting.
	Overspeed - The engine speed has risen above the overspeed pre-alarm setting.
	Generator Under Voltage - The generator output voltage has fallen below the pre-set pre-alarm setting level.
	Generator Over Voltage - The generator output voltage has risen above the pre-set pre-alarm setting after the Safety On timer has expired.
	Generator Under Frequency - The generator frequency has fallen below the pre-set pre-alarm setting after the Safety On timer has expired.
	Generator Over Frequency - The generator output frequency has risen above the pre-set alarm setting
	Analogue Input Configured As Digital - The analogue inputs can be configured to digital inputs. The module detects that an input configured to create a fault condition has become active.
	Charge Failure - The auxiliary charge alternator voltage is low as measured from the W/L terminal.
	Low Fuel Level - The level detected by the fuel level sensor is below the low fuel level pre-set alarm setting.
	High Fuel Level - The level detected by the fuel level sensor is above the high fuel level pre-set alarm setting.
	Delayed Over Current - The measured current has risen above the configured trip level for a configured duration.
	kW Overload - The measured kW has risen above the configured trip level for a configured duration
	CAN ECU Fault - The engine ECU has detected an alarm – CHECK ENGINE LIGHT Contact Engine Manufacturer for support.

	CAN Data Fail - The module is configured for CAN operation and does not detect data on the engine Can data link
	Emergency Stop -The emergency stop button has been depressed. This failsafe (normally closed to emergency stop) input and immediately stops the set should the signal be removed.
	Oil Sender Open Circuit - The oil pressure sensor has been detected as being open circuit.
	Coolant Temperature Sender Open Circuit - The coolant temperature sensor has been detected as being open circuit
	Oil Filter Maintenance Alarm Maintenance due for oil filter.
	Air Filter - Maintenance Alarm Maintenance due for air filter.
	Fuel Filter - Maintenance Alarm Maintenance due for fuel filter.

DSE4510 ELECTRONIC START CONTROL LAYOUT

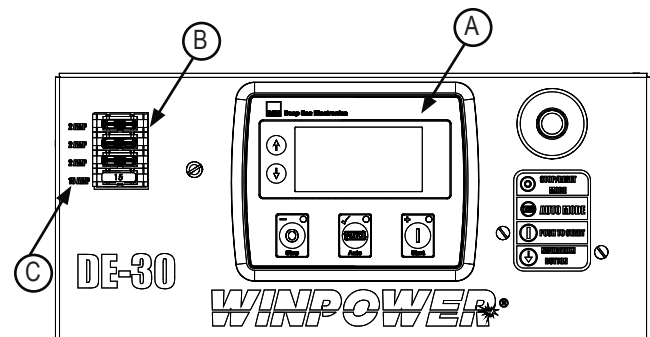

A. Deep Sea 4510 Engine control
See controller explanation on page 12.

B. 2 Amp fuse
These fuses are in the AC input line from the generator that provide the AC Voltage reading on the display. If the fuse is blown, the DSE4510 will not display a voltage or frequency reading and will shutdown on low voltage or frequency. (Replacement fuse ATO-ATC-2A-250 Volt)

C. 10 Amp fuse
This fuse supplies the 12 Volt DC to power the DSE 4510 controller circuits on the boards. If this fuse is blown, the DSE 4510 will not function at all. (Replacement fur ATO-ATC 2A-250 Volt)

DSE4510 INITIAL START UP

WARNING: EQUIPMENT DAMAGE:

DO NOT jump start these engine-generator sets. Starting these units on a low battery or jump starting them will cause damage to the engine control module.

Use the following check list to verify correct installation before starting the engine.

- Engine oil. Fill as required with proper grade/qty.
- Engine coolant. Fill as required with proper mixture.
- Unit mounting base properly bolted down.
- Clearance for service and maintenance on all sides.
- Proper fuel line material and size.
- All fuel line connections tight.
- Battery connections clean and tight
- Battery fully charged.
- All AC and DC wiring installed and properly protected.

After completing the previous checklist, the engine-generator set is ready for initial start-up.

STARTING PROCEDURE

MANUAL MODE

WARNING: EQUIPMENT DAMAGE:

Before attempting to start this unit, complete your pre-start checklist and ensure the generator mainline circuit breaker is in the proper position prior to starting. Starting this unit without it properly connected can cause serious personal injury or equipment damage.

1. Press and release the red Stop/Reset button
2. Press and release the green Start Engine button. The engine-generator set will crank and start automatically. If the engine fails to start, it will display a fault code and the common alarm indicator will start blinking. See the fault code appendix portion of this manual.
3. With the unit running smoothly, check the no load voltage and frequency of the generator output.
4. Once the unit is running and the safety on time has elapsed, the engine monitoring switches are active for low oil pressure and high water temperature.
5. After the engine is up and running, the circuit breaker can be closed to power your loads. During periods of very cold operation, it is best to let the engine warm up for a few minutes before applying the load.
6. When stopping the unit, it is best to turn off all the loads before pressing the stop button. This prevents your loads from getting low voltage while still running during shutdown.

TROUBLE SHOOTING TABLES

ENGINE WILL NOT CRANK:

1. Low/dead battery
2. Blown DC fuses 2 Amp or 25 Amp
3. Defective DSE4510
4. Defective key switch
5. Loose or dirty battery terminals
6. Defective starter
7. Defective Start solenoid
8. Locked up engine genset
9. Defective engine harness
10. Improper battery voltage to start solenoid, fuel pump, or fuel solenoid

ENGINE CRANKS BUT WILL NOT START

1. Improper fuel delivery to the unit
2. Fuel supply shut off
3. Fuel tank empty
4. Air in the fuel system
5. Engine fuel solenoid has not opened
6. Defective fuel pump
7. Defective fuel solenoid
8. Defective engine harness
9. Improper battery voltage to fuel pump or fuel solenoid

ENGINE STARTS, THEN STOPS AND ALARM LIGHT COMES ON

1. Engine oil pressure is low
2. Engine has water temperature
3. Refer to fault code on DSE4510

ENGINE WILL NOT COME UP TO SPEED AFTER IT STARTS

1. Insufficient fuel volume getting to the unit
 - a. Too small of fuel line
 - b. Fuel racks not opened properly
2. Governor is defective
3. AC short in generator components

NO AC OUTPUT FROM GENERATOR

1. Defective Diode
2. Defective voltage regulator
3. Defective rotor
4. Defective stator
5. Defective exciter rotor
6. Defective exciter stator
7. AC short in the output leads
8. Defective/open generator output breaker
9. Wiring error

CONTROL BOX AC WIRING

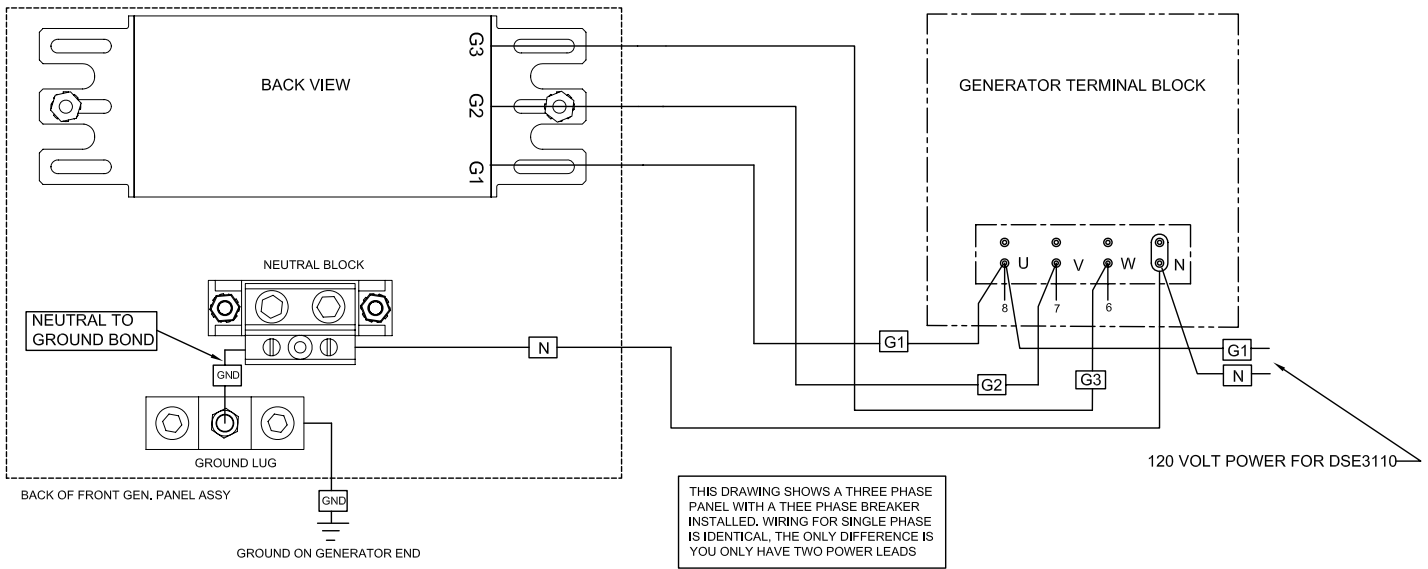

KEY START PANEL SCHEMATIC

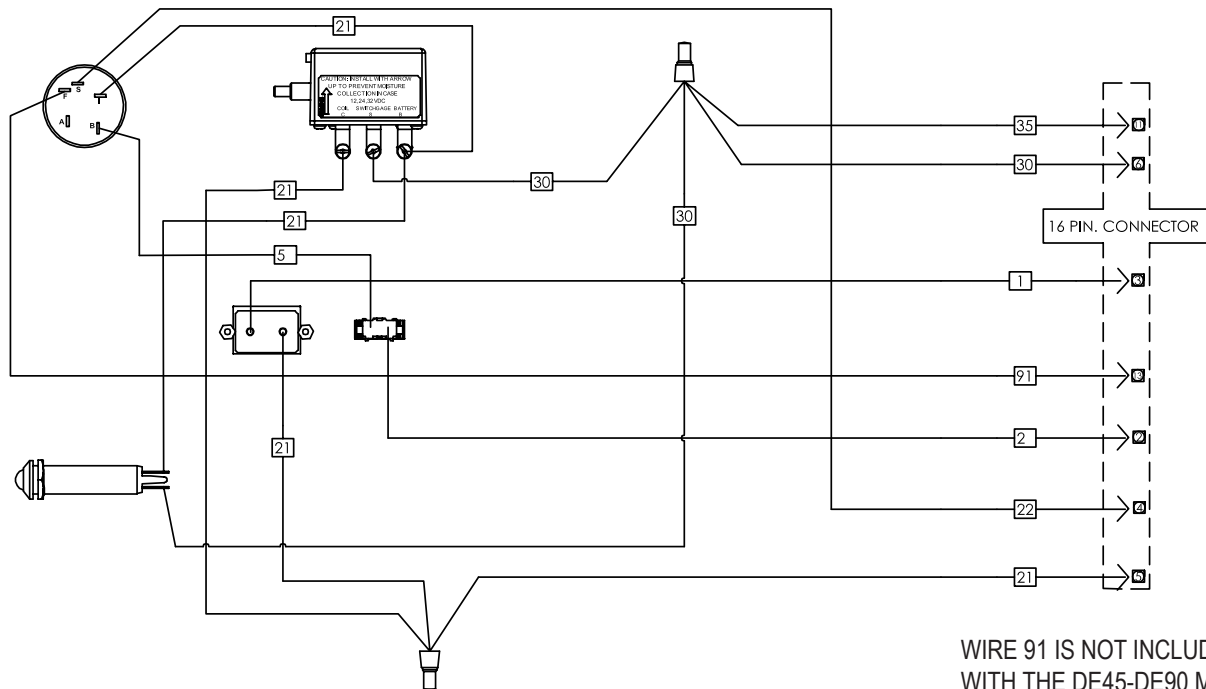

DE20 & DE30 ENGINE HARNESS SCHEMATIC

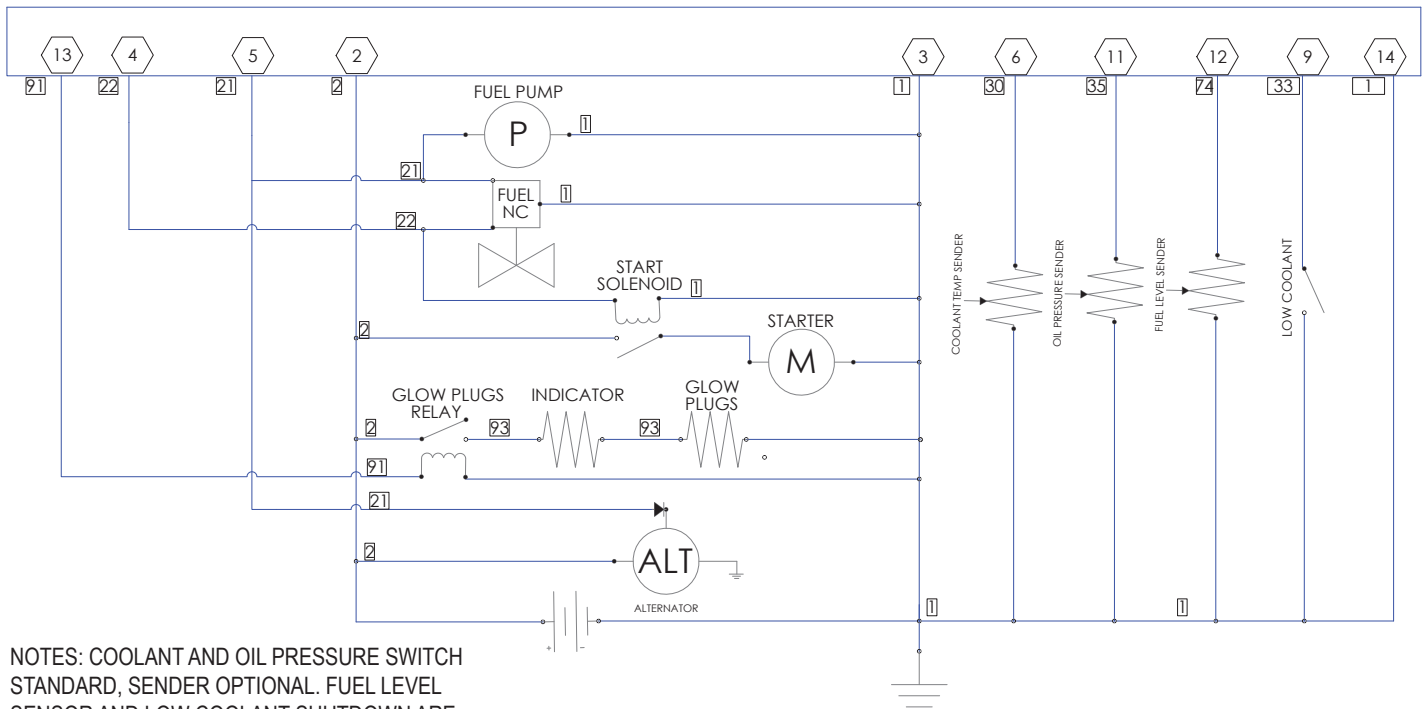

NOTES: COOLANT AND OIL PRESSURE SWITCH STANDARD, SENDER OPTIONAL. FUEL LEVEL SENDER AND LOW COOLANT SHUTDOWN ARE OPTIONAL ACCESSORIES.

DE45 & DE65 ENGINE HARNESS SCHEMATIC

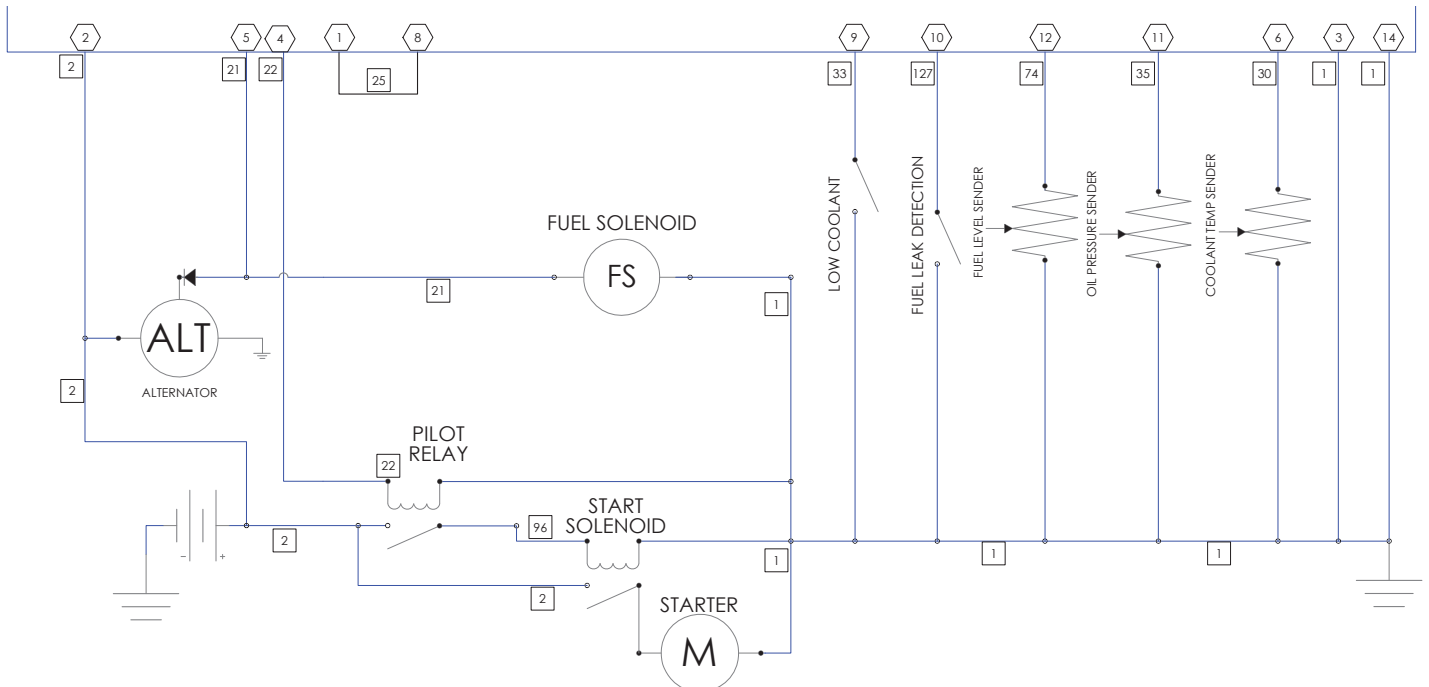

NOTE: LOW COOLANT SWITCH IS OPTIONAL. OIL PRESSURE AND COOLANT TEMPERATURE SENDERS INCLUDED ON MODELS WITH ELECTRONIC ENGINE CONTROLS. FUEL LEVEL IS FOR UNITS WITH TANKS AND LEAK DETECTION FOR UNITS WITH SECONDARY CONTAINMENT.

4510 ELECTRIC START PANEL

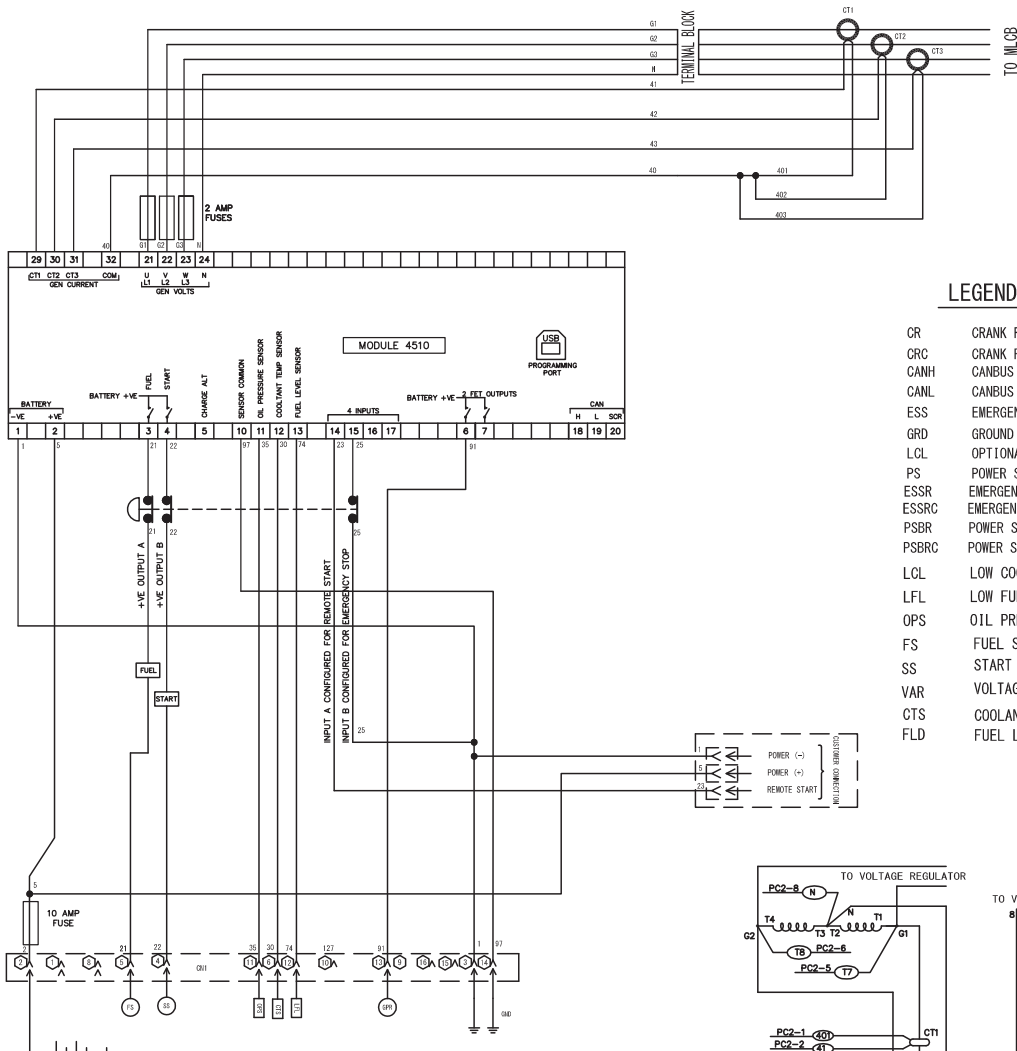

LEGEND

- CR CRANK RELAY
- CRC CRANK RELAY CONTACT
- CANH CANBUS HIGH
- CANL CANBUS LOW
- ESS EMERGENCY STOP SWITCH
- GRD GROUND (CHASSIS OR FRAME)
- LCL OPTIONAL LOW COOLANT LEVEL PROBE
- PS POWER SWITCH (DC)
- ESSR EMERGENCY STOP SWITCH RELAY
- ESSRC EMERGENCY STOP SWITCH RELAY CONTACT
- PSBR POWER SWITCH BYPASS RELAY
- PSBRC POWER SWITCH BYPASS RELAY CONTACT
- LCL LOW COOLANT LEVEL
- LFL LOW FUEL LEVEL
- OPS OIL PRESSURE SENDER
- FS FUEL SOLENOID
- SS START SOLENOID
- VAR VOLTAGE ADJUSTMENT RHEOSTAT
- CTS COOLANT TEMPERATURE SENDER
- FLD FUEL LEAK DETECTION

THIS SIDE OF CONNECTOR 1 REFERENCE ONLY
SOME TERMINALS NOT USED IN ALL CONFIGURATIONS

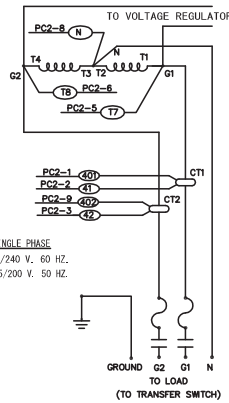
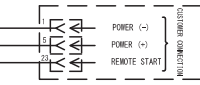

HIGH VOLTAGE SINGLE PHASE
120/208-139/240 V, 60 HZ.
100/173- 115/200 V, 50 HZ.

GENERATOR: SINGLE PHASE

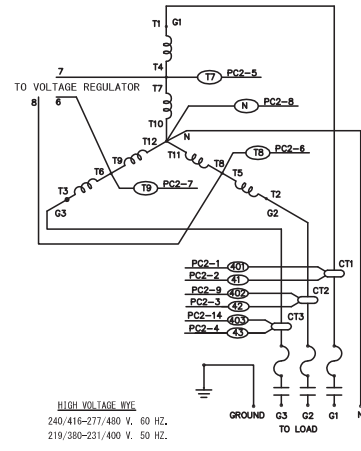

HIGH VOLTAGE WYE
240/416-277/480 V, 60 HZ.
219/380-231/400 V, 50 HZ.

GENERATOR: THREE PHASE

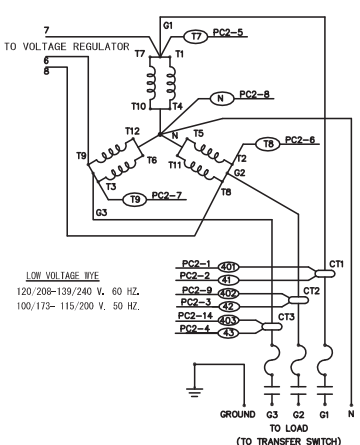

LOW VOLTAGE WYE
120/208-139/240 V, 60 HZ.
100/173- 115/200 V, 50 HZ.

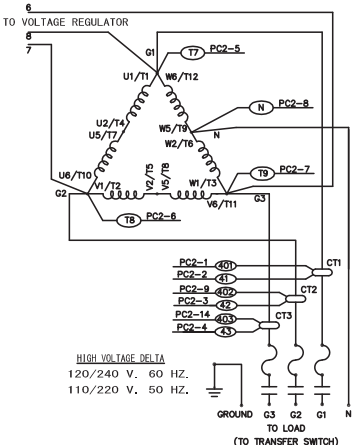

HIGH VOLTAGE DELTA
120/240 V, 60 HZ.
110/220 V, 50 HZ.

GENERATOR: THREE PHASE

THREE PHASE AC WIRE HIGH AND LOW WYE

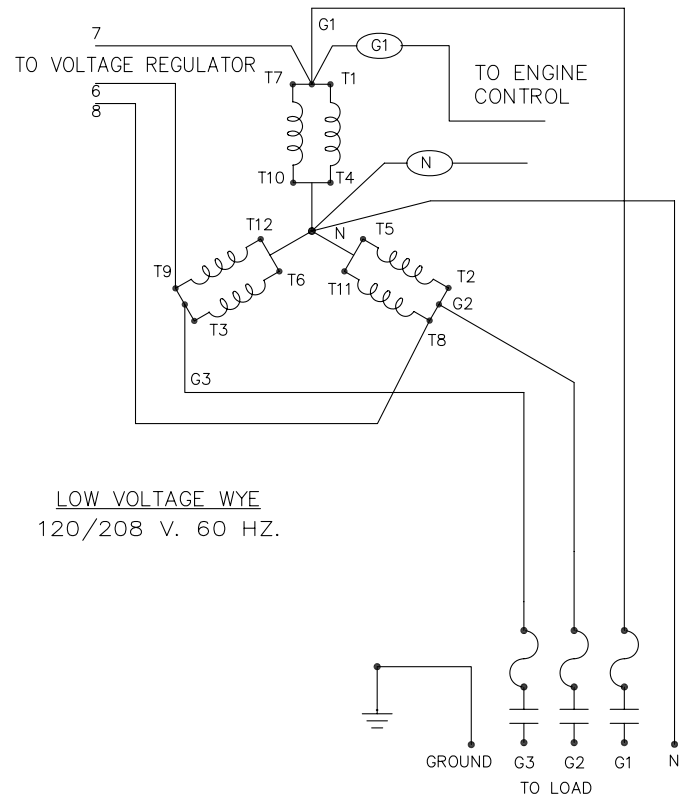
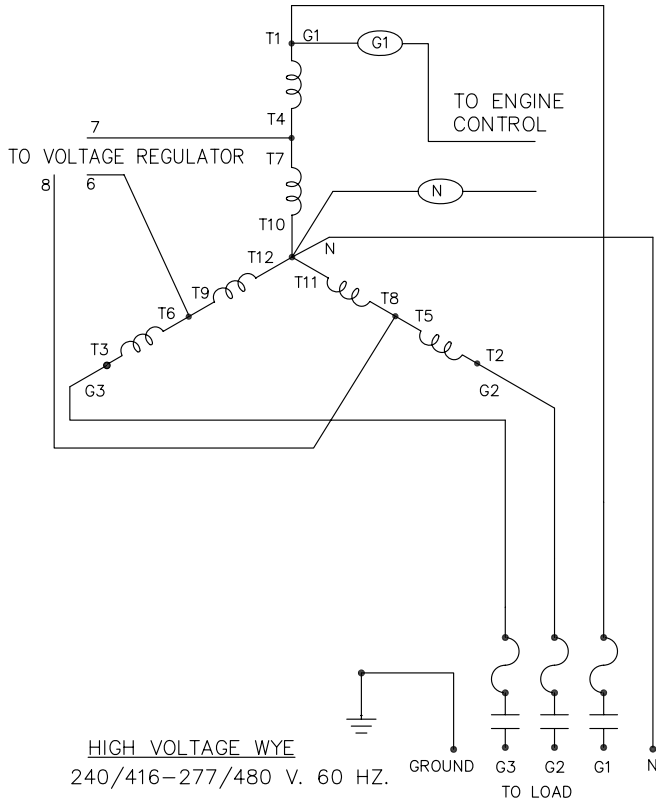

THREE PHASE AC WIRING- DELTA

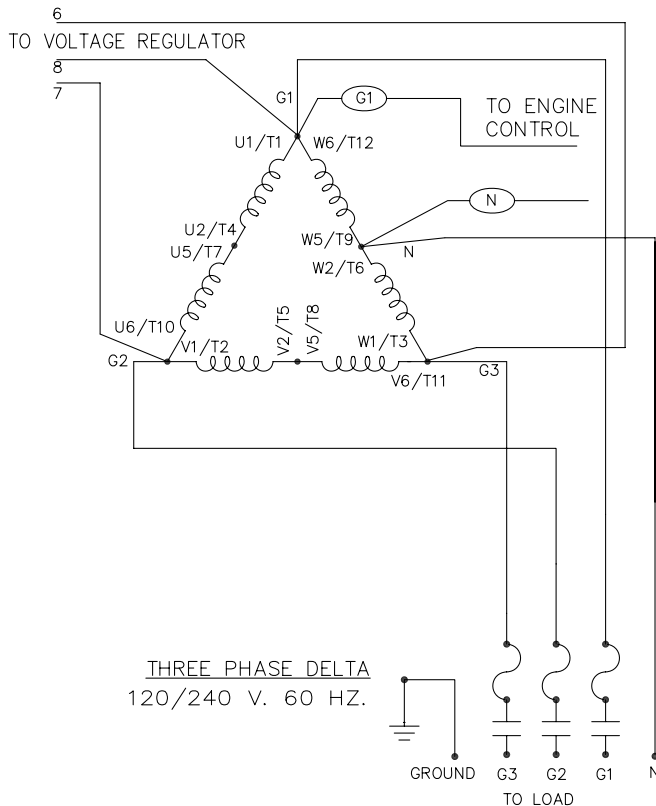

SINGLE PHASE 311 WINDING

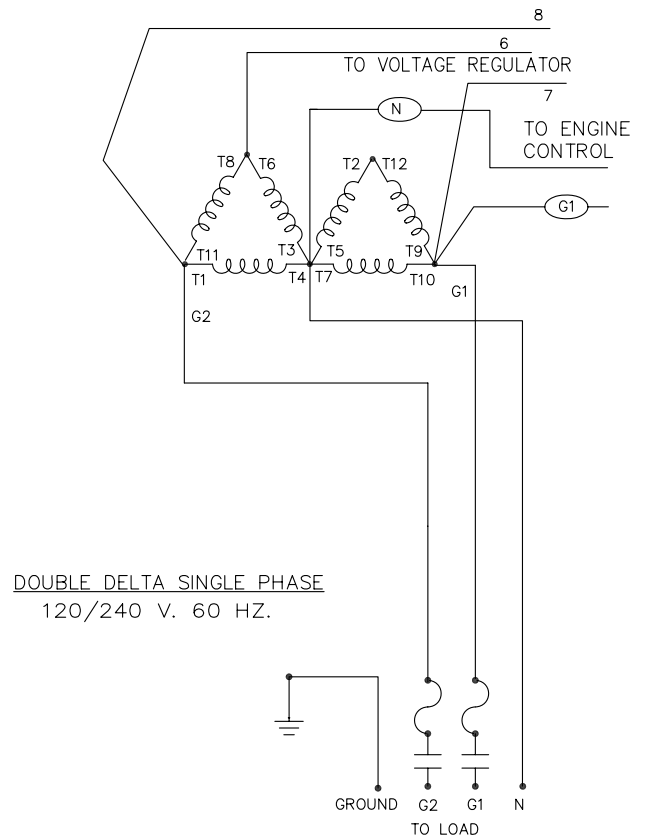



12 MONTH LIMITED WARRANTY

WINCO, Incorporated warrants to the original purchaser for 12 months or 1000 hours which ever occurs first, that goods manufactured or supplied by it will be free from defects in workmanship and material, provided such goods are installed, operated and maintained in accordance with WINCO written instructions.

WINCO's sole liability, and Purchaser's sole remedy for a failure under this warranty, shall be limited to the repair of the product. At WINCO's option, material found to be defective in material or workmanship under normal use and service will be repaired or replaced. For warranty service, return the product within 12 months or 1000 hours which ever occurs first from the date of purchase, transportation charges prepaid, to your nearest WINCO Authorized Service Center or to WINCO, Inc. at Le Center Minnesota.

THERE IS NO OTHER EXPRESS WARRANTY.

To the extent permitted by law, any and all warranties, including those of merchantability and fitness for a particular purpose, are limited to 12 months or 1000 hours which ever occurs first, from date of purchase. In no event is WINCO liable for incidental or consequential damages.

Note: Some states do not allow limitation on the duration of implied warranty and some states do not allow the exclusion or limitation of incidental or consequential damages, so the above limitations may not apply in every instance. This warranty gives you specific legal rights which may vary from state to state.

WINCO reserves the right to change or improve its products without incurring any obligations to make such changes or improvement on products purchased previously.

EXCLUSIONS:

WINCO does not warrant Engines. Engines are covered exclusively by the warranties of their respective manufacturers, see enclosed warranties.

WINCO does not warrant Component Parts that are warranted by their respective manufacturers.

WINCO does not warrant modifications or alterations which were not made by WINCO, Inc.

WINCO does not warrant products which have been subjected to misuse and/or negligence or have been involved in an accident.

This warranty does not include travel time, mileage, or labor for removal or re-installation of WINCO product from its application.