

# Model VI6000

## Digital Inverter Generator



**User's Manual**  
January 2015

**VOLTMASTER®**

## PREFACE

Thank you for purchasing a Voltmaster® inverter generator.

This manual covers the operation and preventive maintenance of the VI6000 generator with EPA and California Air Resources Board (CARB) certification if so designated.

All information in this publication is based on the latest product information available at the time of printing.

We reserve the right to make changes at any time without notice and without incurring any obligation.

No part of this publication may be reproduced without written permission.

This manual should be considered a permanent part of the generator and should remain with it if it is resold.

Pay special attention to statements preceded by the following words:



Failure to properly follow these precautions can result in property damage, serious injury or DEATH!

Read all labels and the owner's manual before operating this generator.

Generators produce carbon monoxide, a poisonous, colorless, odorless gas that can cause death or serious injury.

Indoor use of a generator can kill quickly. Generators should be used outdoors only.

Generators should be used outdoors only and away from garages and open windows and protected from rain and snow.

Always stop engine before refueling. Wait 5 minutes before restarting.  
Keep any source of ignition away from the fuel tank at all times.

The portable generator is not meant to be used as a permanent back-up power system for the home. A permanently installed stationary generator is designed to be safely used for this specific purpose.



Indicates a strong possibility of severe personal injury or death if instructions are not followed.



Indicates a possibility of personal injury or equipment damage if instructions are not followed.

**NOTE** Gives helpful information.

If a problem should arise, or if you have any questions about the generator, consult an authorized dealer or service center.



Our generators are designed to give safe and dependable service if operated according to the instructions. Read and understand the Owner's Manual before operating the generator. Failure to do so could result in personal injury or equipment damage.

# CONTENTS

PREFACE .....	1
CONTENTS .....	3
1. SAFETY INSTRUCTIONS .....	5
2. COMPONENT LOCATIONS .....	8
2.1 Exterior View .....	8
2.2 Inlet System.....	9
2.3 Exhaust System.....	9
2.4 CARB Evaporative Control System .....	10
2.5 Carbon Canister .....	11
2.6 Control Panel.....	12
2.7 Serial Number.....	12
3. PRE OPERATION CHECK .....	13
3.1 Engine Oil Level .....	13
3.2 Fuel Level.....	14
3.3 Air Cleaner.....	15
4. STARTING THE GENERATOR .....	16
5. GENERATOR USE .....	19
5.1 AC Power Application .....	21
5.2 Output and Overload Indicators.....	22
5.3 Voltage Selection Switch .....	23
5.4 Smart Throttle.....	24
5.5 Air Conditioning Operation.....	24
5.6 DC Power Application.....	25
6. STOPPING THE GENERATOR .....	27
7. MAINTENANCE .....	28
7.1 Emission Control System .....	28
7.2 Maintenance Schedule.....	31
7.3 Changing The Oil.....	31
7.4 Air Cleaner Service.....	32
7.5 Spark Plug Service .....	33
7.6 Spark Arrestor Maintenance .....	35

8. TRANSPORTING/STORAGE .....	36
9. TROUBLESHOOTING .....	37
10. SPECIFICATIONS .....	39
11. WIRING DIAGRAM .....	40
12. WHEEL KIT .....	41

---

# 1. SAFETY INSTRUCTIONS

---

## WARNING

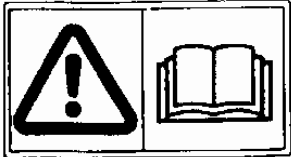

- Our generators are designed to give safe and dependable service if operated according to these instructions.

Read and understand the owner's manual before operating the generator. Failure to do so could result in personal injury or equipment damage.

## WARNING

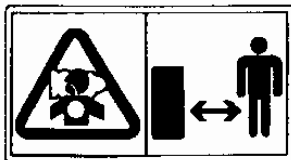

- Exhaust gas contains poisonous carbon monoxide.

Never run the generator in an enclosed area.

Be sure to provide adequate ventilation.

## WARNING

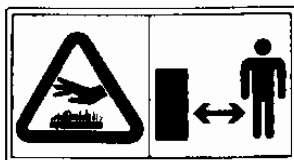

The muffler becomes very hot during operation and remains hot for several minutes after stopping the engine.

Be careful not to touch the muffler while it is hot.

Let the engine cool before storing the generator indoors.

The engine exhaust system will be heated during operation and remain hot immediately after stopping the engine.

To prevent burns, pay attention to the warning marks attached to the generator.

## WARNING

The generator must be operated outside with adequate ventilation.

It cannot be operated in an enclosed compartment of any vehicle or garage area.

To ensure safe operation:



■ Gasoline is extremely flammable and explosive under certain conditions. Refuel in a well ventilated area with the engine stopped.

■ Keep away from smoking materials, sparks and other sources of combustion when refueling the generator. Always refuel in a well-ventilated location.

■ Wipe up spilled gasoline at once.

■ Restrict use of the generator in high-hazard risk areas.

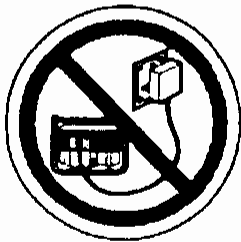

■ Connections for standby power to a building's electrical system must be made by a qualified electrician and must comply with all applicable laws and electrical codes. Improper connections can allow electrical current from the generator to back feed into the utility lines. Such back feed may electrocute utility company workers or others who contact the lines during a power outage, and when utility power is restored, the generator may explode, burn, or cause fires in the building's electrical system. This generator is not designed to be connected to an automatic transfer switch. Serious damage to the engine and inverter module may result.

■ Always make a pre-operation inspection before you start the engine.

■ Place the generator at least three feet or one meter away from buildings or other equipment during operation.

■ Operate the generator on a level surface to prevent fuel spillage or oil starvation.

■ Know how to stop the generator quickly and understand operation of all the controls. Never permit anyone to operate the generator without proper instructions. Keep children and pets away from the generator when it is in operation.

- Never operate the generator with the door open or any panels removed. Do not operate in any enclosure such as an RV compartment.
- Keep away from rotating parts while the generator is running.
- The generator is a potential source of electrical shocks when misused; do not operate with wet hands.
- Do not operate the generator in rain or snow or let it get wet.



---

## 2. COMPONENT LOCATIONS

---

### 2.2 Inlet System

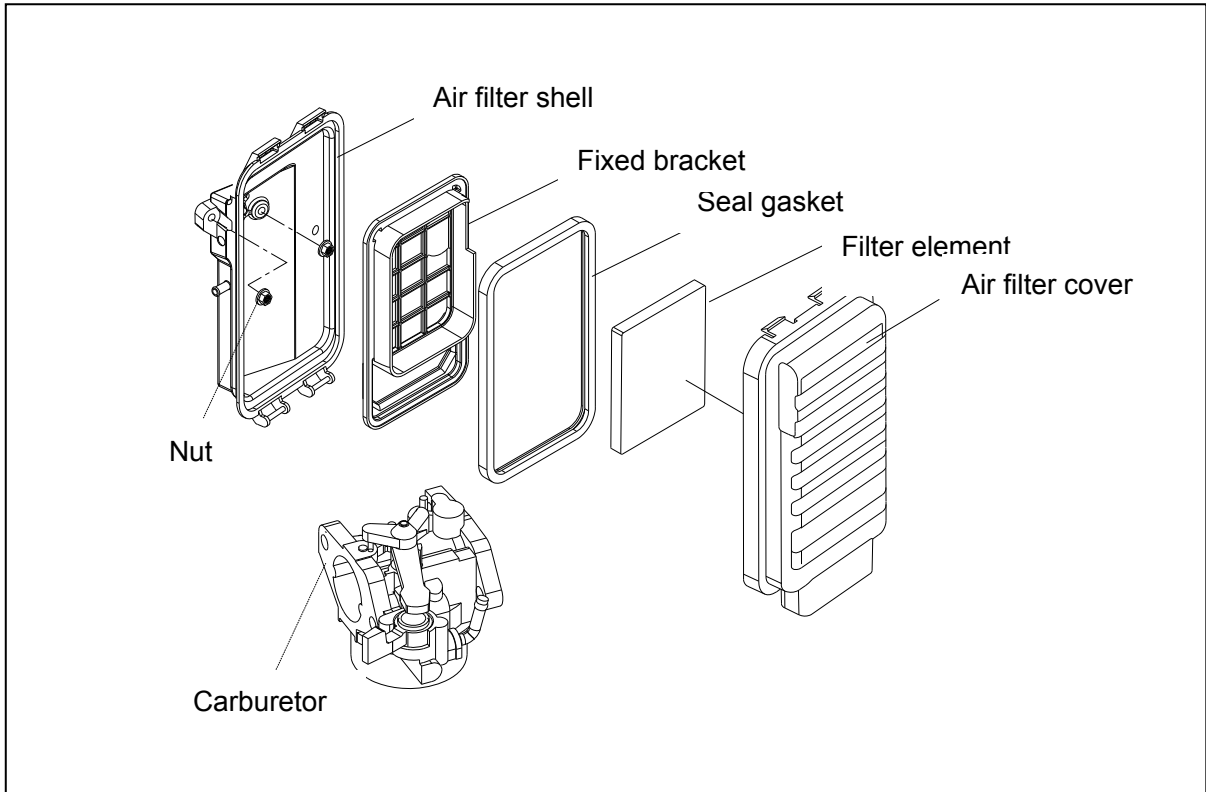

## 2.3 Exhaust System

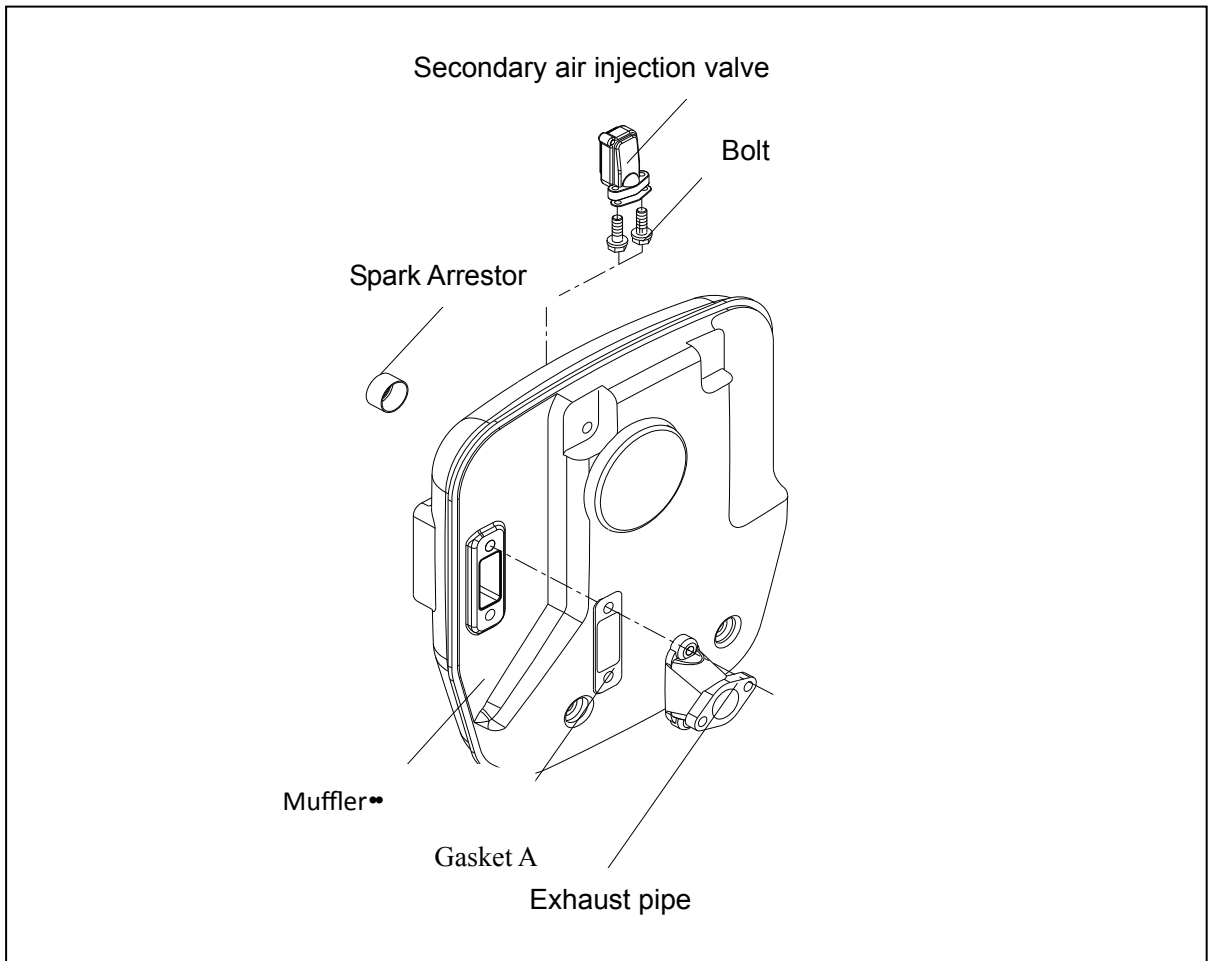

## 2.4 CARB Evaporative Control System

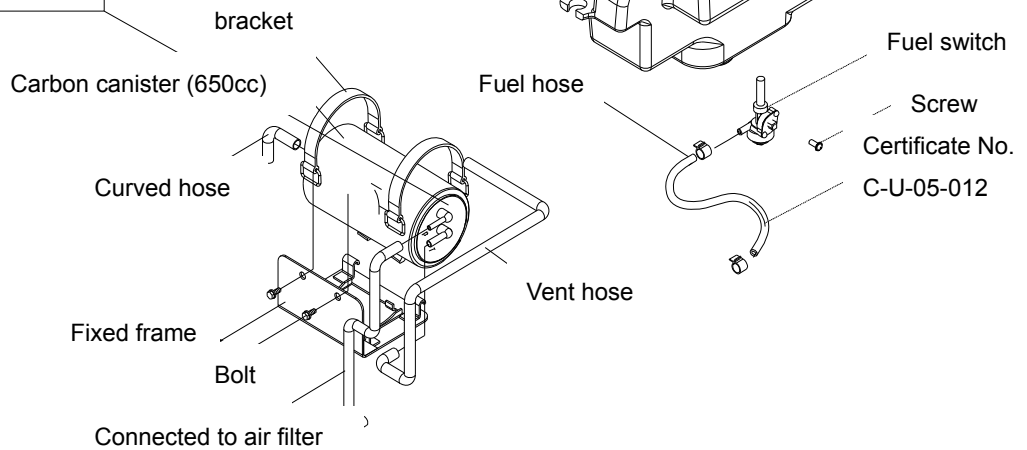
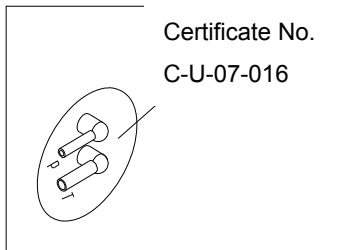
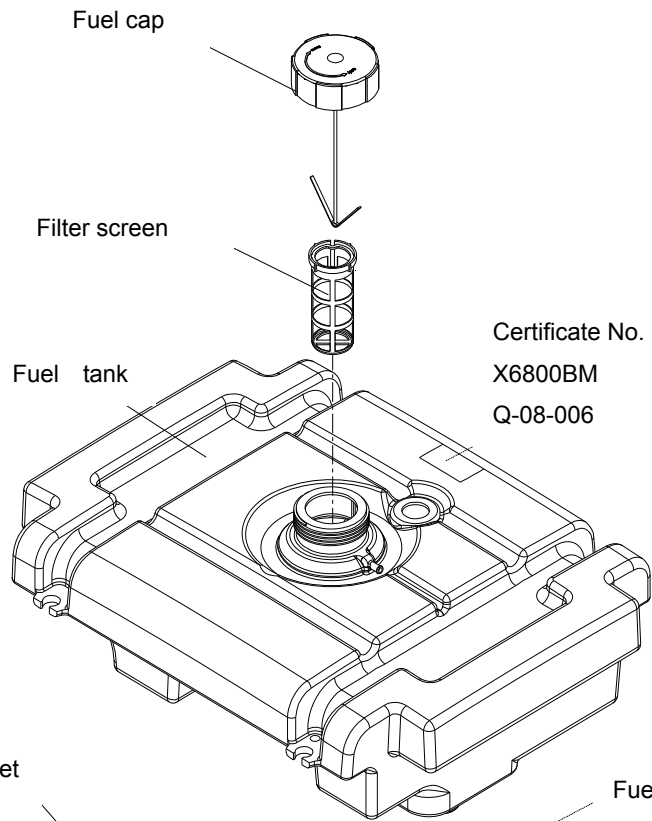
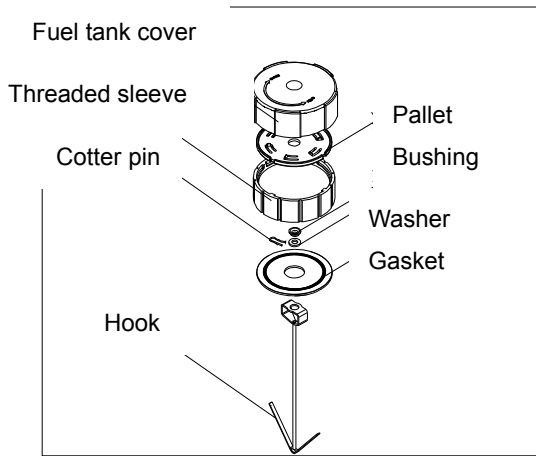

## 2.5 Carbon Canister Location (CARB only)

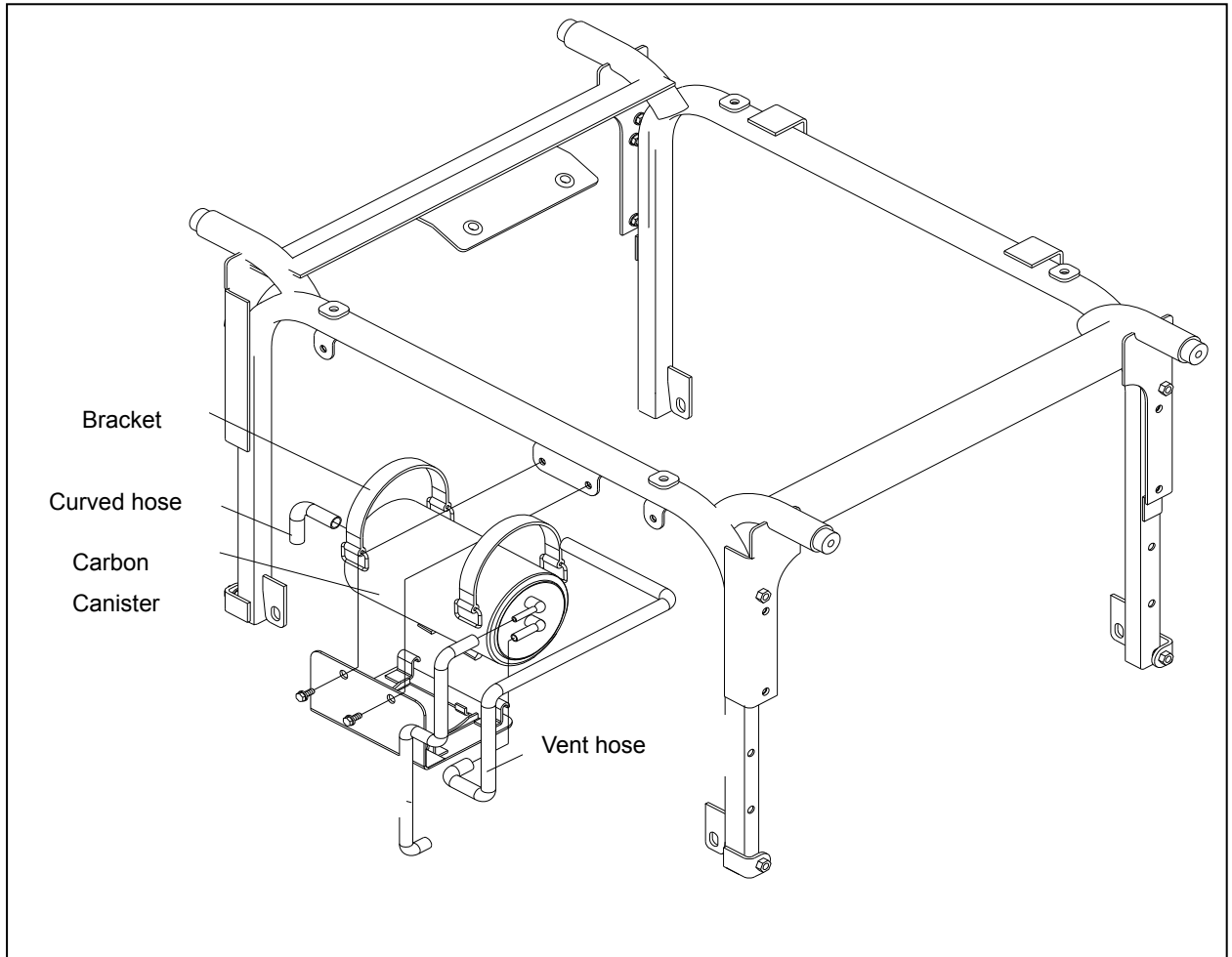

## 2.6 Control Panel

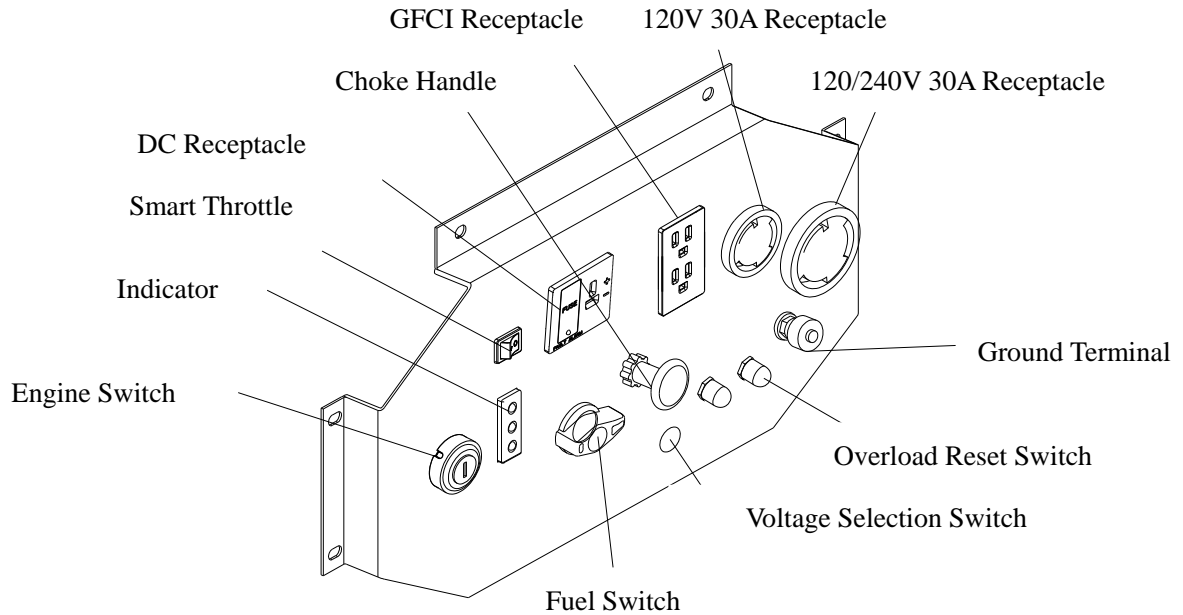

## 2.7 Serial Number

The engine serial number is stamped on the engine block to the left of the oil drain plug. In most cases the battery will have to be removed to view it clearly. Refer to this number when ordering parts or making technical inquiries.

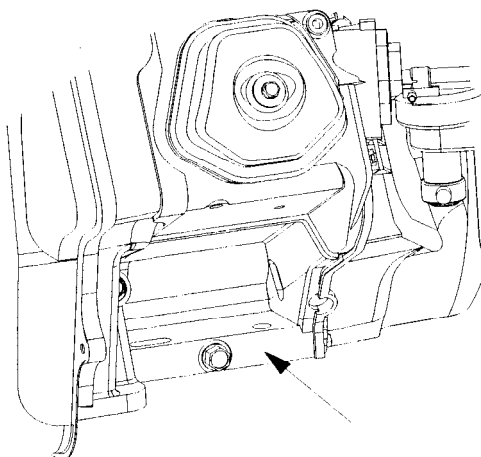

### 3. PRE-OPERATION CHECK

Be sure to check the generator on a level surface with the engine stopped.

#### 3.1 Check the engine oil level

#### ⚠ WARNING

- Using non detergent or 2-stroke engine oil could shorten the engine's service life.
- Use a high-detergent, premium quality four cycle engine oil, certified to meet or exceed U.S. Automobile manufacturer's requirements for API Service Classification SG/SF.
- Select the appropriate viscosity for the average temperature in your area.

#### SAE Viscosity Grades

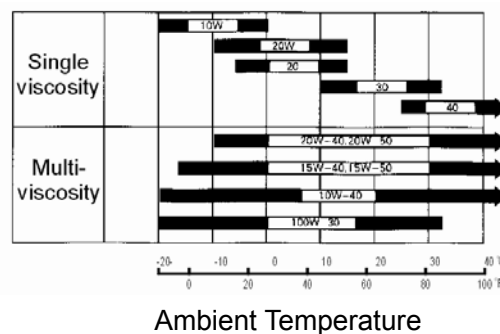

Open the service door. Remove the oil filler cap and wipe the dipstick with a clean rag. Check the oil level by inserting the dipstick in the filler hole without screwing it in. If the oil level is below the end of the dipstick, refill with recommended oil up to the top of the oil filler neck.

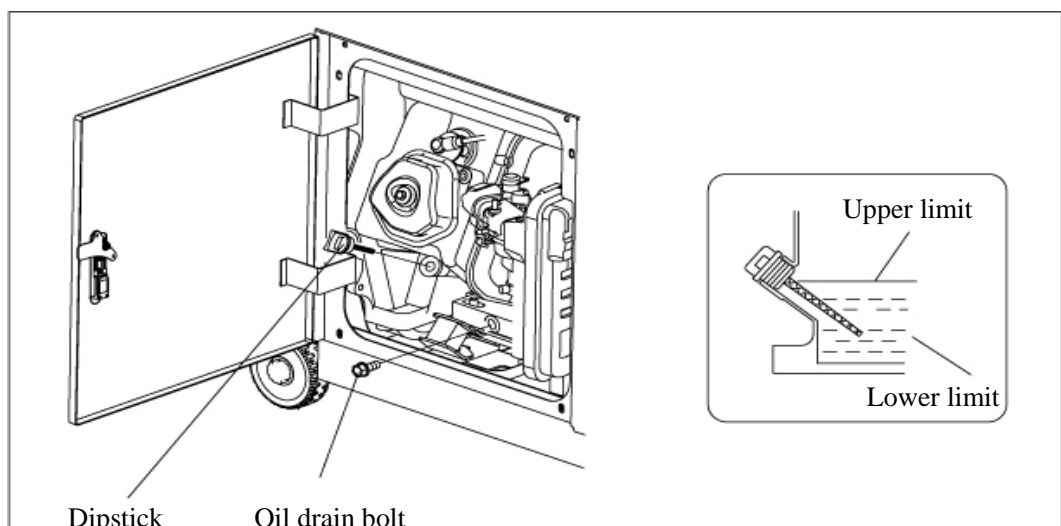

## **⚠ CAUTION**

- Running the engine with insufficient oil can cause serious engine damage.
- The oil Alert System will automatically stop the engine before the oil level falls below the safe limit. However, to avoid the inconvenience of an unexpected shutdown, it is still advisable to visually inspect the oil level before each use.

### **3.2 Check the fuel level**

Use unleaded 87 octane regular gasoline Do not use premium or high octane fuels.

The engine is tuned to run on regular gasoline and engine damage and poor performance may result from using higher octane fuels.

If the fuel level is low, refill to the shoulder of the fuel strainer.

Never use an oil/gasoline mixture or dirty gasoline.

Avoid getting dirt, dust or water in the fuel tank.

After refueling, tighten the fuel filler cap securely.

## **⚠ WARNING**

- Gasoline is extremely flammable and is explosive under certain conditions.
- Refuel in a well-ventilated area with the engine stopped. Do not smoke or allow flame or sparks in the area where the engine is refueled or where gasoline is stored.
- Do not overfill the fuel tank (there should be no fuel in the filler neck). After refueling, make sure the fuel filler cap is closed properly and securely.
- Be careful not to spill fuel when refueling. Spilled fuel or fuel vapor may ignite. If any fuel is spilled, make sure the area is dry before starting the engine.
- Avoid repeated or prolonged contact with skin or breathing of vapors. KEEP OUT OF REACH OF CHILDREN.

Fuel tank capacity: 5.8 gallons or 22 liters

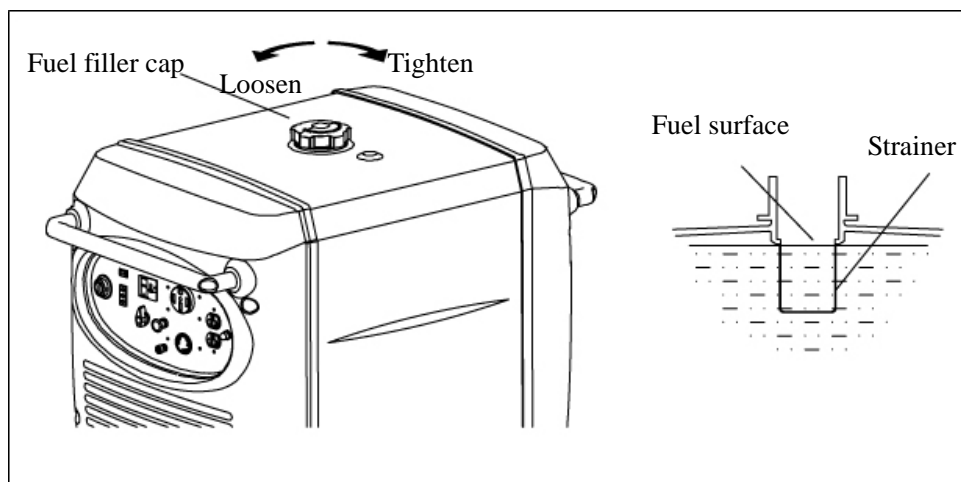

## **GASOLINES CONTAINING ALTERNATE FUELS**

If you decide to use a gasoline containing ethanol be sure its octane rating is no lower than the specification. Do not use a blend that contains more than 10% ethanol. Do not use gasoline containing methanol.

### **3.3 Check the air cleaner**

Check the air cleaner elements to be sure they are clean and in good condition.

Open the service cover. Remove the air cleaner cover and remove the paper air cleaner element. Replace the element if dirty or damaged.

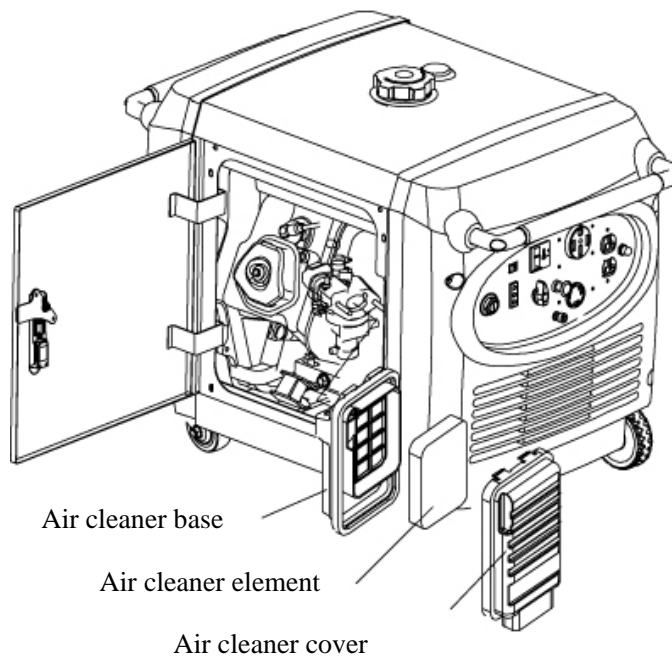

Air Cleaner Assembly

### **⚠ CAUTION**

■ Never run the engine without the air cleaner. Rapid engine wear will result from contaminants such as dust and dirt, being drawn through the carburetor, into the engine.



---

## 4. STARTING THE GENERATOR

---

### CAUTION

■ When starting the generator after adding fuel for the first time, after long-term storage, or after running out of fuel, turn the fuel valve lever to the "ON" position then wait 10 to 20 seconds before starting the engine.

- a. Turn the fuel valve lever to the ON position.

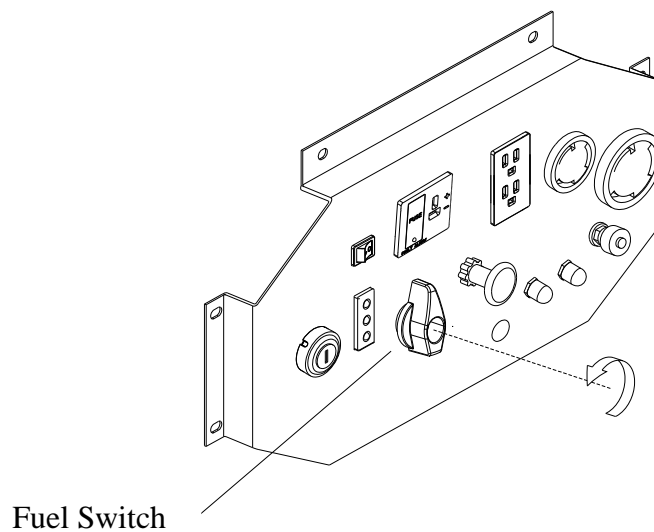
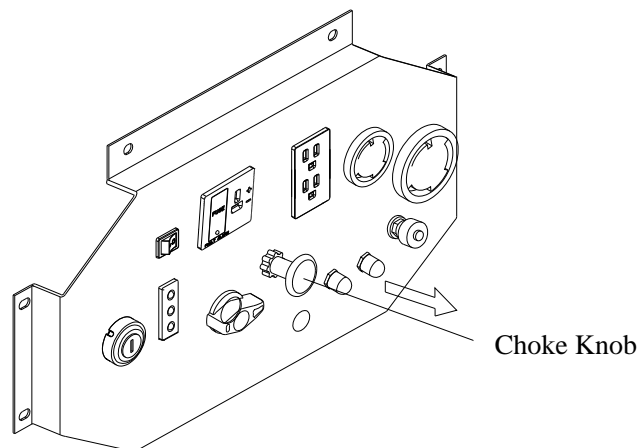

Fig. 7

- b. Pull the choke knob out to the CLOSED position

Do not use the choke when the engine is warm or the air temperature is high,



c. Insert the engine key and turn the ignition switch to ON position.

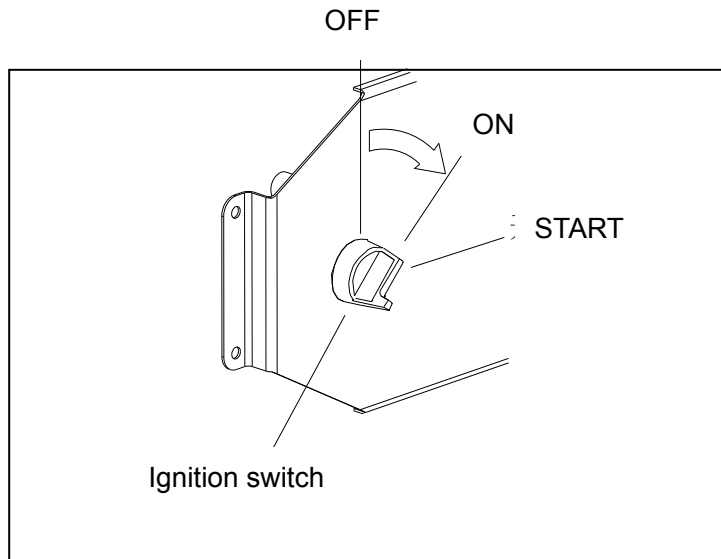

d. Turn the ignition switch to the START until the engine starts.

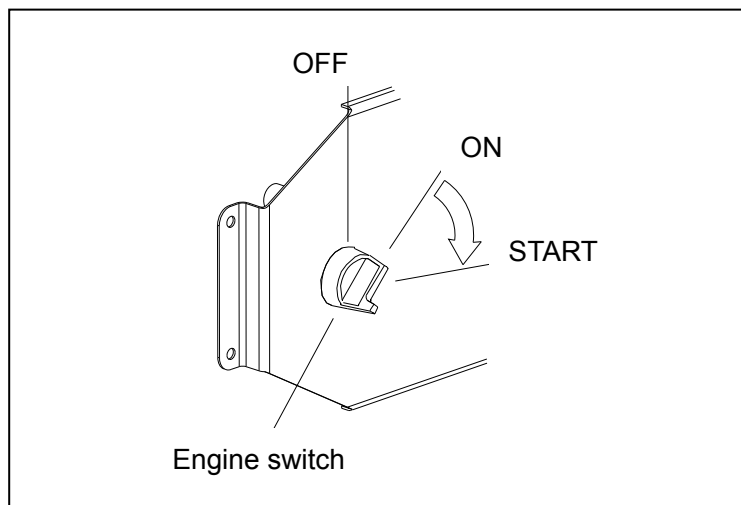

4.5 Push the choke knob to the OPEN position as the engine warms up

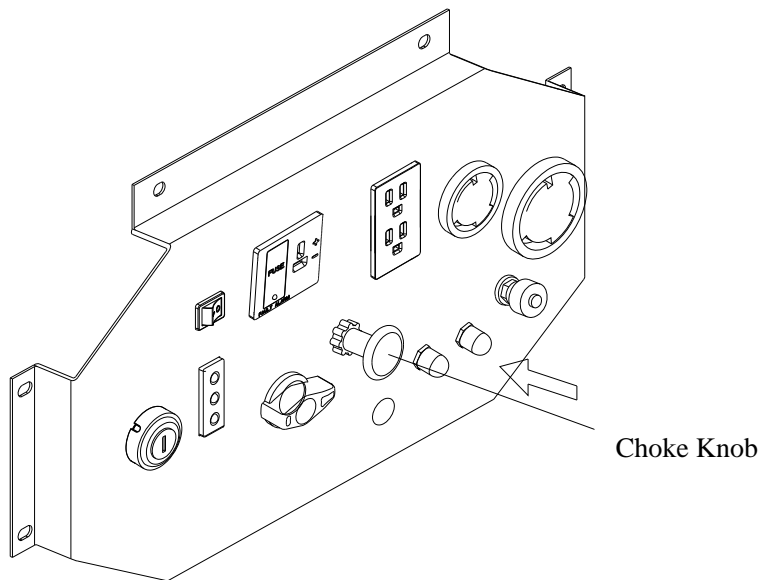

### High altitude operation

At high altitude, the standard carburetor air-fuel mixture will be excessively rich. Performance will decrease, and fuel consumption will increase.

High altitude performance can be improved by installing a smaller diameter main fuel jet in the carburetor.. If you operate the generator at altitudes higher than 5,000 feet (1,500m) above sea level, have your authorized dealer perform the jet replacement..

Even with suitable carburetor jetting, engine horsepower will decrease approximately 3.5% for each 1000 feet (350m) increase in altitude. The effect of altitude on the horsepower will be greater than this if no carburetor modification is made.

### CAUTION

■ Operation of the generator at an altitude lower than the carburetor is jetted for may result in reduced performance, overheating, and serious engine damage caused by an excessively lean air/fuel mixture.

---

## 5. GENERATOR USE

---

### WARNING

■ To prevent electrical shock from faulty appliances, the generator should be grounded. Connect a length of heavy wire between the generator's ground terminal and an external ground source.

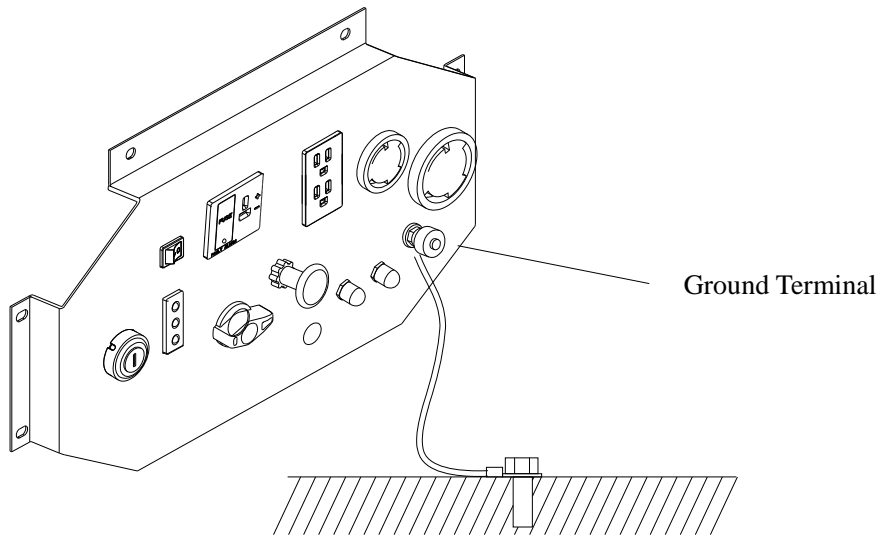

### CAUTION

■ Limit operation requiring maximum power to 30 minutes. For continuous operation do not exceed the rated power. In either case, the total wattage of all appliances connected must be considered.

■ Do not exceed the current limit specified for any one receptacle.

■ Do not connect the generator to a household circuit. This could cause the damage to the generator or to electrical appliances in the house.

■ Do not modify or use the generator for other purposes than which it is intended. Also observe the following when using the generator:

- Do not connect generators in parallel.
- Do not connect an extension to the exhaust pipe.

■ When an extension cable is required, be sure to use tough rubber sheathed flexible cable.

■ Keep the generator away from other electric cables or wires such as commercial power supply lines.

## NOTE

- You may use DC receptacle when using AC supply.
- If you want to use AC and DC receptacle simultaneously, the total output should not be over the sum output of AC and DC.
- Electrical equipment containing the wiring and plug should not have defect.

## Control panel

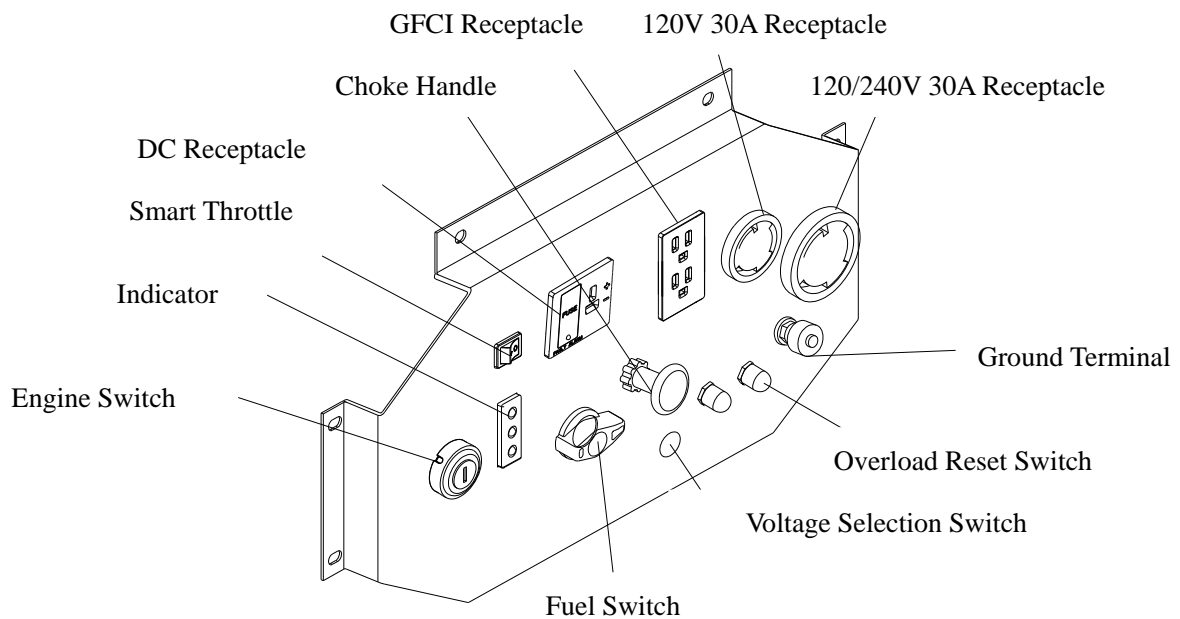

## 5.1 AC Application

1. Start the engine and make sure the green output indicator light comes on.

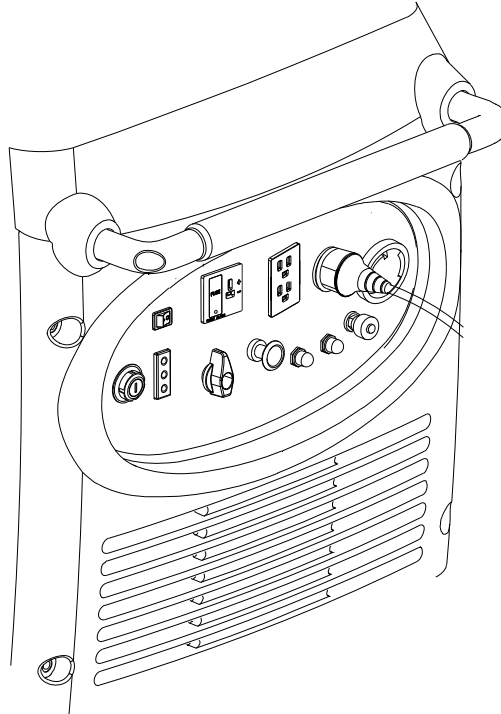

2. Confirm that the appliance to be used is switched off and plug in the appliance.

### CAUTION

- Be sure that all appliances are in good working order before connecting them to the generator. If an appliance begins to operate abnormally, becomes sluggish, or stops suddenly, turn off the generator engine switch immediately. Disconnect the appliance and examine it for signs of malfunction.

## 5.2 Output and Overload Indicators

The green output indicator light will remain ON during normal operating conditions. If the generator is overloaded or if there is a short in the connected appliance the output indicator will go OFF and the overload indicator will go ON and current to the connected appliance will be shut off. Correct the overload condition and press the overload reset switch on the panel to restore AC power.

Check the engine oil level if the red low oil indicator comes ON.

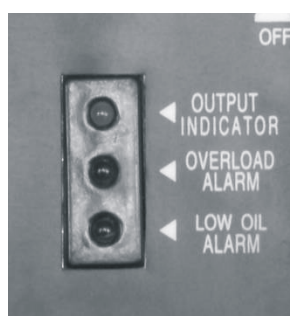

### NOTICE

■ Before connecting an appliance to the generator, check that it is in good order and that its electrical rating does not exceed that of the generator.

Then connect the power cord of the appliance and start the engine.

### NOTICE

■ When an electric motor is started, both the overload indicator light and the output indicator light may go on simultaneously. This is normal if the overload indicator light goes off after about four seconds. If the overload indicator light stays on, consult your dealer.

The two 120V receptacles are rated at 20 and 30 amps respectively. Should this current be exceeded, the circuit protection device will activate and cut all current to the receptacle. This will be indicated by the push button popping out. Reduce the load to the receptacle and reset the circuit protector by pushing in the button.

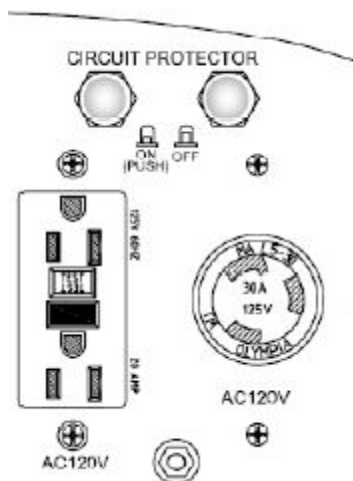

### 5.3 Voltage Selection Switch

The voltage selection switch has two positions: AC120V and AC120/240V.

1. When the voltage selection switch is in the 120/240V position, the generator supplies both 120V and 240V AC power. If you operate the generator with the switch in this position, the electric current is limited to 15 amps to the 120V receptacles although it can provide 15 amps at 240V from the 120/240V receptacle.
2. When the voltage selection switch is in the 120V position, the generator supplies 120V AC only. It can supply a full 30 amps to the 30 Amp receptacle or 20A to the GFCI receptacle. Total current is limited to 45.8 amps at rated load.



## 5.4 Smart Throttle



When the SMART throttle is placed in the on position, engine speed is kept at idle automatically when the electrical load is disconnected and returns to the proper speed required by the electrical load when the load is reconnected. The engine speed varies according to the amount of load applied to the generator. Placing the smart throttle in the on position is recommended to minimize fuel consumption and engine noise while in operation.

### **NOTE**

- When high electrical load appliances are connected simultaneously, turn the SMART throttle switch to the OFF position to reduce voltage fluctuation.
- The SMART throttle system does not operate efficiently if the electrical appliance will be used in a rapid on-off or low to high rpm mode.

When the smart throttle is in the off position, the engine runs at rated load RPM.

## 5.5 Air Conditioning Operation

For best results, the SMART throttle switch should be in the off position. Bring the generator to a normal operating temperature before applying the air conditioning load. Always allow a 2 minute wait period when manually cycling an air conditioner off and on. A longer wait period may be required under unusually hot weather conditions. Additionally, all other loads should be turned off until the air conditioner has started and is performing normally. It is also important to follow the air conditioner manufacturer's instructions for starting and restarting for proper operation. Some air conditioner manufacturers offer

a start capacitor as an extra cost option. The lack of a start capacitor can cause the air conditioner to draw too high a starting current and overload the generator. Contact your air conditioner dealer if you consistently have problems starting your air conditioner with the generator.

## 5.6 DC Power Application

The DC receptacle may be used for charging 12 volt automotive-type batteries only. It is not designed to operate DC motors. Output voltage is 15-30V. DC output will vary according to the position of the Smart throttle switch.

a. Connect the charging cable to the DC receptacle of the generator and then to the battery terminals.

### **WARNING**

- To prevent the possibility of creating sparks near the battery, connect the charging cable first to the generator then to the battery. Disconnect the cable first at the battery.
- Before connecting the charging cable to a battery that is installed in a vehicle, disconnect the vehicle's battery ground cable. Reconnect the vehicle's ground cable after the charging cables are removed. This procedure will prevent the possibility of a short circuit and sparks if accidental contact is made between a battery terminal and the vehicle's frame or body.
- Do not attempt to start an automobile engine with the generator still connected to battery. The generator may be damaged.
- Connect the positive battery terminal to the positive charging cord. Do not reverse the charging cables or serious damage to the generator and/or battery may occur.

**! WARNING**

■ The battery gives off explosive gases: keep sparks, flames and cigarettes away. Provide adequate ventilation when charging.

■ The battery contains sulfuric acid (electrolyte). Contact with skin or eyes may cause severe burns. Wear protective clothing and a face shield.

A. If electrolyte gets on your skin, flush with water.

B. If electrolytes gets in your eyes, flush with water for at least 15 minutes and call a physician.

■ Electrolyte is poisonous.

If swallowed, drink large quantities of water or milk and follow with milk of magnesia or vegetable oil and call a physician.

■ Keep out of reach of children.

**! CAUTION**

The DC output is to be used to charge batteries only. Serious damage to the stator windings can occur if connected to a DC motor or transformer.

b. Start the generator.

■ The DC receptacle may be used while the AC power is in use.

■ The DC receptacle is protected from an overload with a fuse. If the DC circuit is overloaded, the 5 amp fuse will blow and power to the DC receptacle will cease. The red light on the DC panel will illuminate. The fuse is located to the left of the receptacle and is accessed by snapping open the access door.

Replace the fuse with one of the same capacity. Using a higher rated fuse may cause damage to the generator alternator.

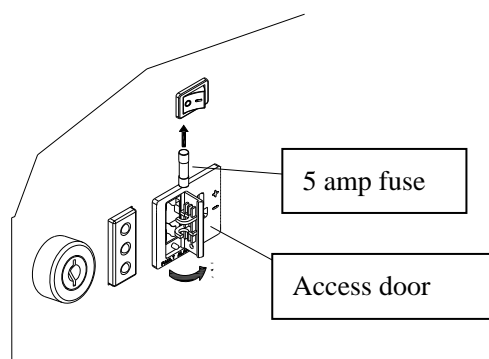

---

## **6. STOPPING THE GENERATOR**

---

To stop the engine in an emergency, turn the engine switch OFF.

In normal use:

1. Switch off the connected equipment and pull the plug from the receptacle.
2. Turn off the ignition switch.
3. Turn the fuel valve lever to the OFF position.

---

## 7. MAINTENANCE

---

The purpose of the maintenance and adjustment schedule is to keep the generator in the best operating condition.

### **WARNING**

- Shut off the engine before performing any maintenance. If the engine must be run, make sure the area is well ventilated. The exhaust contains poisonous carbon monoxide gas.

### **CAUTION**

- Use genuine Voltmaster parts or the equivalent. The use of replacement parts which are not of equivalent quality may damage the generator.

### 7.1 Emission Control System

#### Emission source

Exhaust gas contains carbon monoxide, nitrous oxide (NO<sub>x</sub>), and hydrocarbons. It is very important to control the emissions of NO<sub>x</sub> and hydrocarbons as they are a major contributor to air pollution. Carbon monoxide is a poisonous gas. The emission of fuel vapors is a source of pollution as well. The generator engine employs a precise air-fuel ratio and emission control system to reduce the emissions of carbon monoxide, NO<sub>x</sub>, hydrocarbons, and evaporative fuel emissions.

#### Regulation

Your engine has been designed to meet current Environmental Protection Agency (EPA) and the California Air Resources Board (CARB) clean air standards. The regulations dictate that the manufacturer provide operation and maintenance standards regarding the emission control system. Tune up specifications are provided in the Specifications section and a description of the emission control system may be found in the appendix to this manual. Adherence to the following instructions will ensure your engine meets the emission control standards.

## **Modification**

Modification of the emission control system may lead to increased emissions.

Modification is defined as the following:

- Disassembling or modifying the function or parts of the intake, fuel or exhaust system.
- Modifying or destroying the speed governing function of the generator.

## **Engine faults that may affect emission**

Any of the following faults must be repaired immediately. Consult with your authorized Voltmaster service center for diagnosis and repair:

- Hard starting or shut down after starting
- Unstable idle speed
- Shut down or backfire after applying an electrical load
- Backfire or afterfire.
- Black smoke and/or excessive fuel consumption

## **Replacement parts and accessories**

The parts making up the emission control system applied to the engine have been specifically approved and certified by the regulatory agencies. You can trust that Voltmaster replacement parts have been manufactured to the same production standard as the original parts. The use of replacement parts or accessories which are not supplied by Voltmaster may affect the engine emission performance. The manufacturers of replacement parts and accessories have the responsibility to guarantee that their replacement products will not adversely affect emission performance.

## **Maintenance**

Maintain the generator according to the maintenance schedule in this section. Service items more frequently when used in dusty areas, or under conditions of high load, temperature, and humidity.

## Air Quality Index (only for California certified models)

CARB requires that an air quality index label be attached to every certified engine showing the engine emission information for the emission duration period. The label is provided for the user to compare the emission performance of different engines. The lower the air index, the better the engine emission performance. The description of durability is helpful for the user to learn the engine emission duration period and the service life of emission control system. Refer to the warranty section of this owner's manual for more information.

EMISSION CONTROL INFORMATION	
FAMILY NAME: ISUZU 2700ACTRIVE PWR CARB Part-1-CO2372	
ENGINE DISPLACEMENT: 2700cc (165cu in) (Other Name)	
THIS ENGINE MEETS U.S. EPA PHASE 2001 CALIFORNIA EMI AND DVE	
EMISSION REGULATIONS FOR SMALL OFF-ROAD MACHINES.	
THIS ENGINE IS CERTIFIED TO OPERATE ON GASOLINE,	
NO OTHER ADJUSTMENTS NEEDED.	
THE AIR INDEX OF THIS ENGINE IS 3	
0	10
BEST CLEAN	WORST CLEAN
NOTE: THE LOWER THE AIR INDEX, THE LESS POLLUTION.	
THIS ENGINE IS CERTIFIED TO BE DISEASE COMPLIANT FOR THE FOLLOWING USE:	
<input type="checkbox"/> DOMESTIC CONSUMER	<input checked="" type="checkbox"/> INTERMEDIATE CONSUMER
<input type="checkbox"/> EXTENDED CONSUMER	
CHECK OWNER MANUAL FOR FURTHER DETAILS.	
000-2011-J F B A M J J A S O R D WUKI SUZUKI POWER CO., LTD.	

## 7.2 Maintenance Schedule

REGULAR SERVICE PERIOD (1) Perform at every indicated month or operating hour interval, whichever occurs first		EACH USE	FIRST MONTH OR 20 HRS	EVERY 3 MONTHS OR 50 HRS	EVERY 6 MONTHS OR 100 HRS	EVERY YEAR OR 300 HRS
ITEM						
Engine oil	Check	○				
	Change		○		○	
Air cleaner	Check	○				
	Clean			○ (2)		
Spark plug	Clean-adjust				○	
Spark arrester	Clean				○	
Fuel sediment cup	Clean				○	
Valve clearance	Check-adjust					○ (3)
Fuel tank and strainer	Clean					○ (3)
Fuel line	Check	Every 2 years (Replace if necessary)(3)				

NOTE: (1) Log hours of operation to determine proper maintenance.

(2) Service more frequently when used in dusty areas.

(3) These items should be serviced by an authorized dealer unless the owner has the proper tools and is mechanically proficient. See the service manual.

## 7.3 Changing Oil

Drain the oil while the engine is still warm.

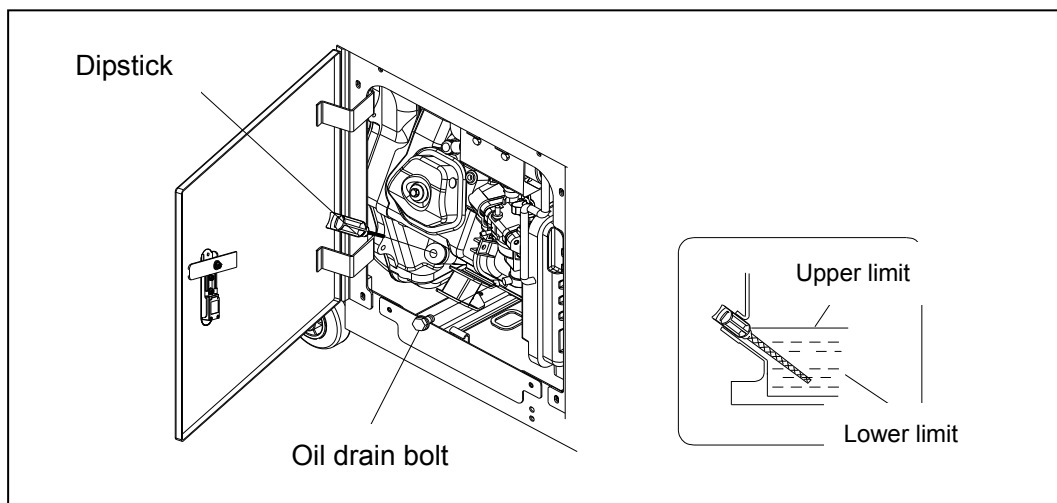



1. Open the left side maintenance cover.
2. Take out the oil outlet plug.
3. Remove the drain bolt, and drain the oil. Retighten the bolt securely.
4. Refill with the recommended oil and check the level.
5. Close the left side maintenance cover.

Engine oil capacity: 1.1L

#### NOTE

■ Please dispose of used motor oil in a manner that is compatible with the environment. We suggest you take it in a sealed container to your local service station for reclamation. Do not throw it in the trash or pour it on the ground.

### 7.4 Air Cleaner Service

A dirty air cleaner will restrict air flow to the carburetor to prevent carburetor malfunction, service the air cleaner regularly. Service more frequently when operating the generator in extremely dusty areas.

#### WARNING

■ Do not use gasoline or low flash point solvents for cleaning. They are flammable and explosive under certain conditions.

#### CAUTION

■ Never run the generator without the air cleaner. Rapid engine wear may result

1. Open the left side maintenance cover.
2. Unsnap the clips, remove the air cleaner cover.
3. Inspect the air cleaner. Replace if dirty or the replacement is called for based on hours of operation.
4. Reinstall the air cleaner cover.
5. Close and latch the left side maintenance cover.

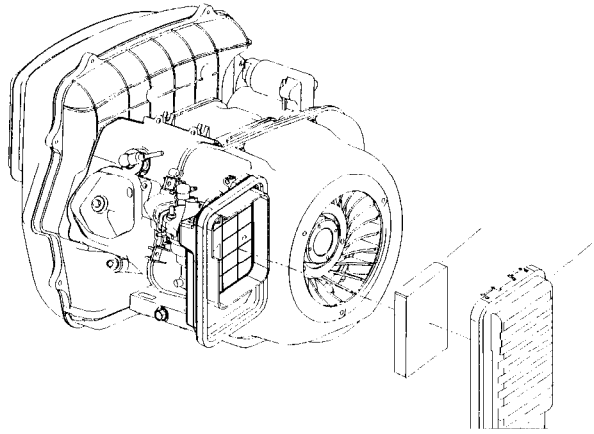

### 7.5 Spark Plug Service

Recommended spark plug: WR7DC

To ensure proper engine operation, the spark plug must be properly gapped and free of deposits.

1. Open the left side maintenance cover.
2. Remove the spark plug cap.

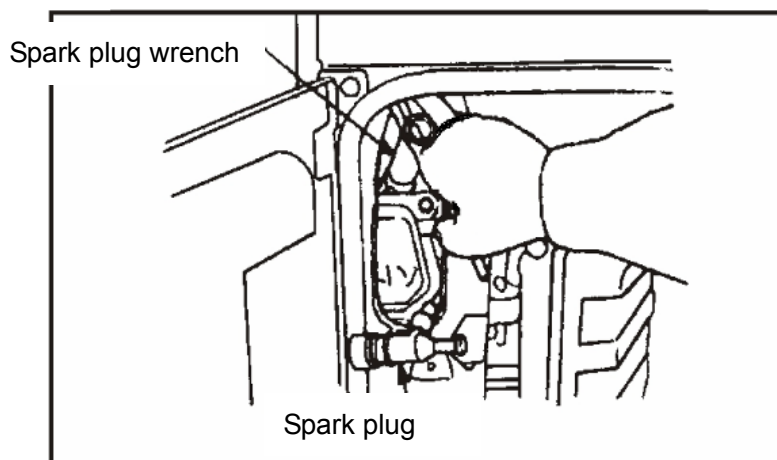

3. Clean dirt from around the spark plug base.
4. Use the wrench to remove the spark plug.
5. Visually inspect the spark plug. Discard it if the insulator is cracked or chipped

Clean the spark plug with a wire brush if it is to be reused.

6. Measure the plug gap with a feeler gauge.

The gap should be 0.7-0.8mm (0.028-0.031in). Correct as necessary by carefully bending the side electrode.

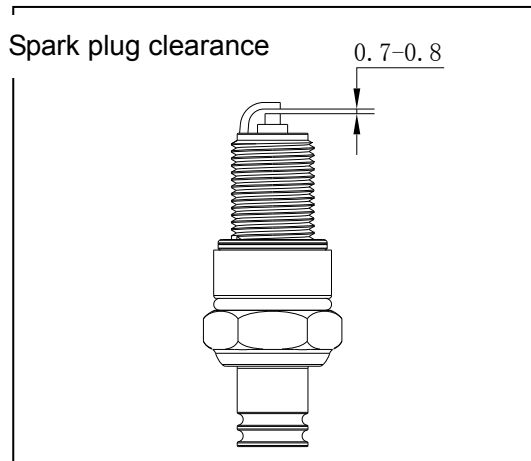

### CAUTION

- The spark plug must be securely tightened. An improperly tightened plug can become very hot and possibly damage the generator.
- Never use a spark plug with an improper heat range.

7. Install the spark plug carefully, by hand, to avoid cross-threading.

8. After a new spark plug has been seated by hand, it should be tightened 1/2 turn with a wrench to compress its washer.

If a used plug is being reinstalled, it should only require 1/8 to 1/4 turn after being seated.

9. Reinstall the spark plug inspection cover and tighten the cover screw.

10. Close and latch the left side maintenance cover.

## 7.6 Spark Arrestor Maintenance

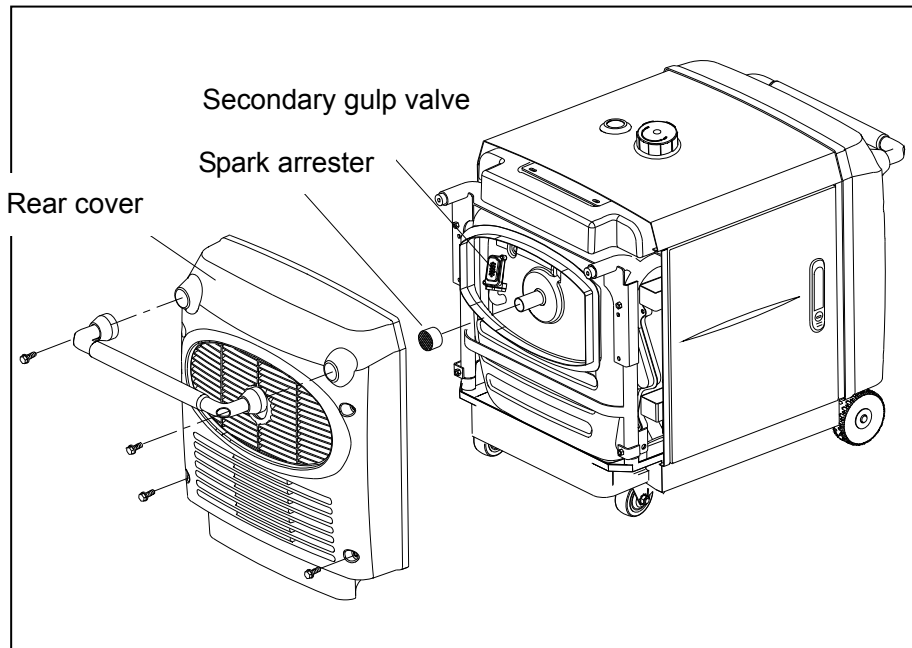

Fig, 17

### WARNING

■ If the generator has been running, the muffler will be very hot. Allow it to cool before proceeding.

### CAUTION

■ The spark arrester must be serviced every 100 hours to maintain its efficiency.

1. Remove the back cover.
2. Remove the exhaust tail pipe and spark arrester.
3. Use a brush to remove carbon deposits from the spark arrester screen.

### NOTE

■ Inspect the spark arrester screen for holes or tears. Replace if necessary.

4. Reinstall the spark arrester.
5. Reinstall the upper muffler protector.

---

## 8. TRANSPORTING/STORAGE

---

a. When transporting the generator, turn the fuel valve lever OFF and keep the generator level to prevent fuel spillage. Fuel vapor or spilled fuel may ignite. Do not transport the generator in a vehicle with fuel in the tank.

b. Exercising the generator

It is essential that the generator be exercised on a regular basis. This will prevent the accumulation of varnish or sludge in the fuel system and also remove moisture from the generator windings. Additionally, seals and other moving engine parts are kept lubricated and the battery is recharged.

Exercise the generator by running it with at least a 1/2 load (1500W) for 60 minutes per month. Gasoline fuel treatments to prevent contamination of your fuel supply are available from your dealer. Fuel varnishing necessitating replacement of the carburetor is not a warrantable failure.

c. Before storing the unit for an extended period:

1. Ensure the storage area is free of excessive humidity and dust.
2. Drain the fuel
  - A. Open the left side maintenance cover.
  - B. Turn fuel valve lever to ON and then loosen the carburetor drain screw. Drain the gasoline from the carburetor and fuel tank into a suitable container.

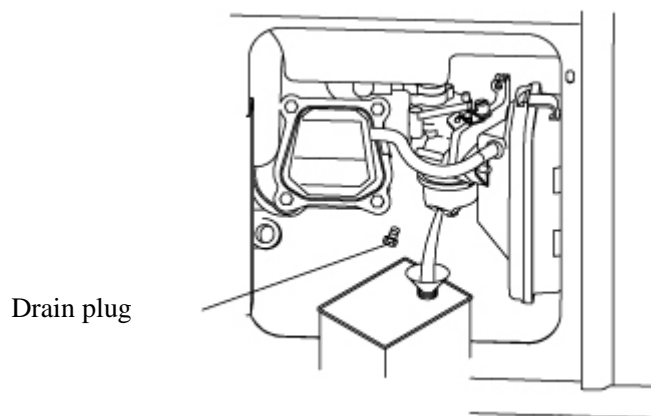
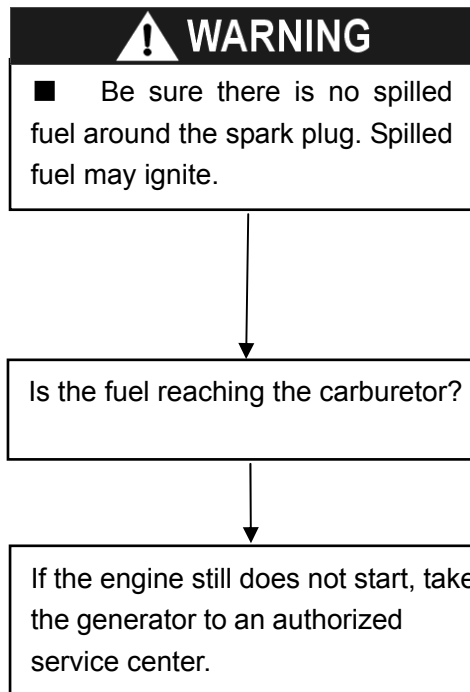
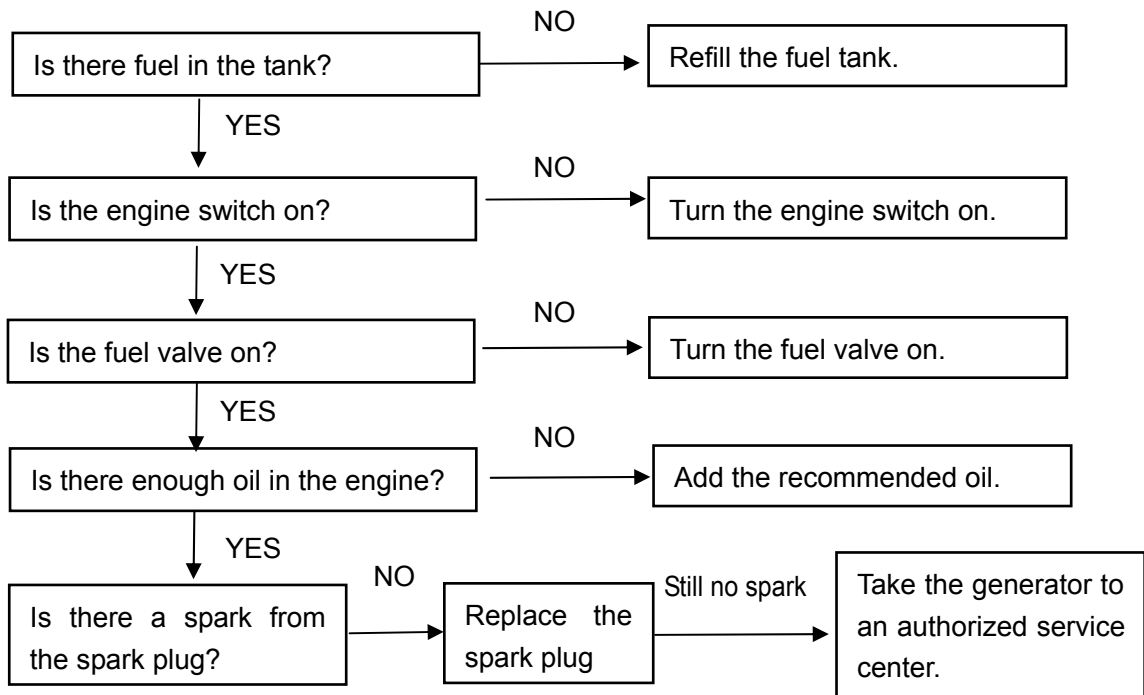

Fig.19 Drain the fuel

3. Once a month, recharge the battery.
4. Change the engine oil.
5. Remove the spark plug and pour one tablespoon of clean engine oil into the cylinder. Crank the engine several revolutions to distribute the oil and then reinstall the spark plug.

## 9. TROUBLESHOOTING

When the engine will not start:



To check:

- 1) Remove the spark plug cap and clean any dirt from around the spark plug.
- 2) Remove the spark plug and install the spark plug in the plug cap.
- 3) Set the plug side electrode on the cylinder head to ground.
- 4) Crank the engine; sparks should jump across the gap.

To check:

- 1) Turn off the fuel valve and loosen the drain screw.
- 2) Fuel should flow from the drain when the fuel valve is turned on.

**AC appliance does not operate:**

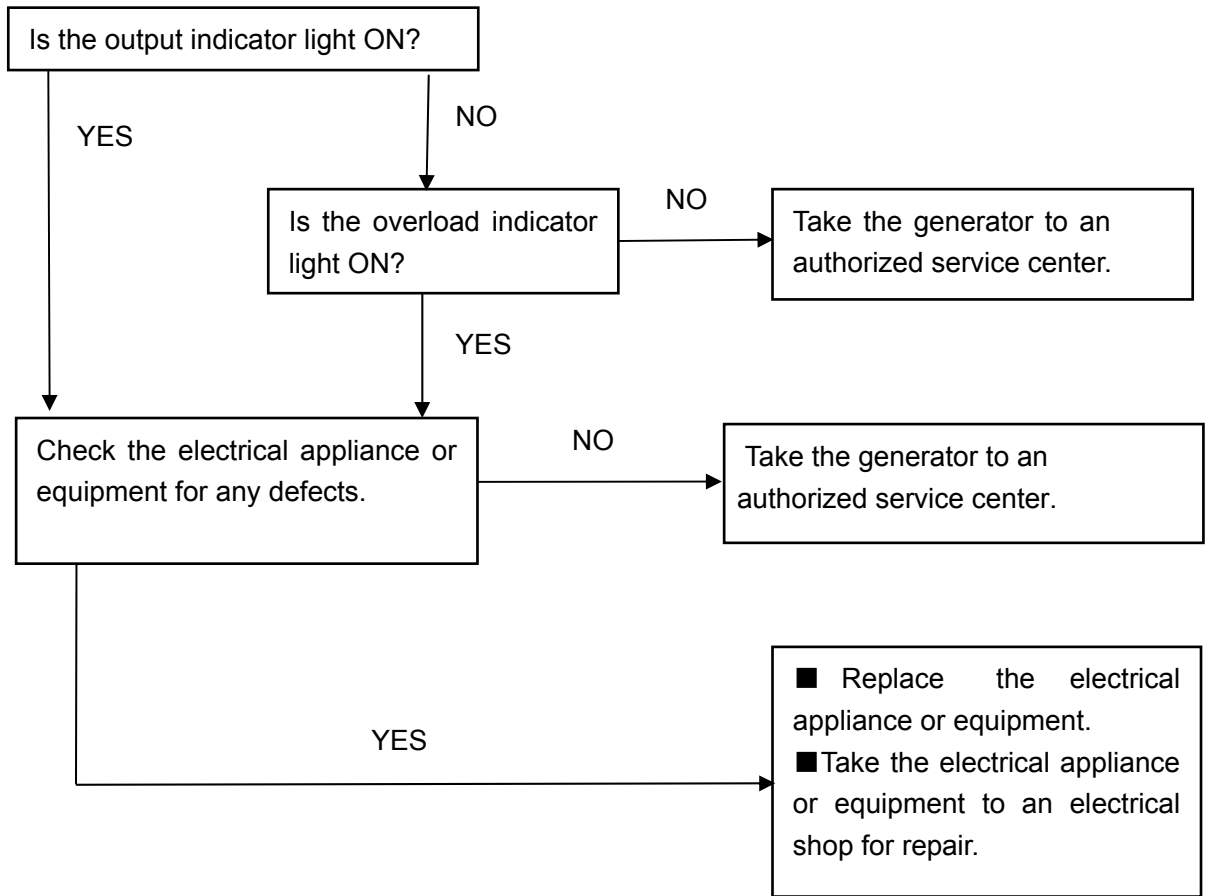

**No output at the DC receptacle:**

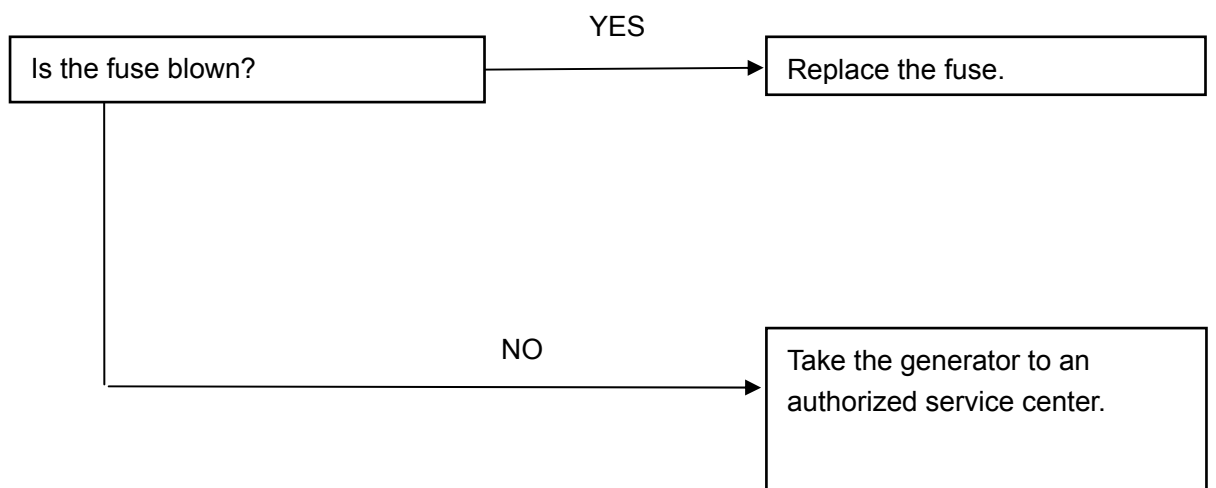

## 10. SPECIFICATIONS

### GENERATOR

Model	VI6000
Rated frequency (Hz)	60
Rated voltage (V)	120/240
Rated current (A)	45.8/22.9
Rated output (Watts)	5500
Max output (Watts)	6000
DC voltage	12V@5.0A
Phase	Single

### ENGINE

Model	KG390GTi
Type	Single cylinder, 4 stroke, vertical, air-cooled, OHV, gasoline engine
Displacement (Bore × Stroke)	23.7 cu. In. (389 cc)
Compression ration	8.5:1
Rated power [kW(hp)/(r/min)]	7.7/3600
Rated rotation speed (rpm)	3600
Ignition system	T. C. I
Spark plug	WR7DC
Starting system	Electric starter/manual recoil
Fuel	Automotive unleaded gasoline, 87 octane
Lube oil	SAE 10W30 (above CC grade)
Lube oil capacity	1.2 qt. (1.1L)

### GENERAL

Fuel tank capacity (L)	5.8gal.(22L)
Continuous running time at rated output	7.5 Hours
Noise level(zero load~ full load) @ 23' (7M)	64-65 decibels
Overall dimension (L×W×H) in. (mm)	48.6×25.59×30.3 (1235×650×770)
Dry weight –lbs (kg)	263 (115)

### Tune Up Specifications

Spark Plug Gap	0.024-0.028 in (0.6-0.7 mm)
Valve Clearance- cold (Intake)	0.0039 ±.0008 in (0.10 ± 0.02 mm)
Valve Clearance- cold (Exhaust)	0.0059 ± .0008 in (0.10 ± 0.02 mm)



# 11. WIRING DIAGRAM

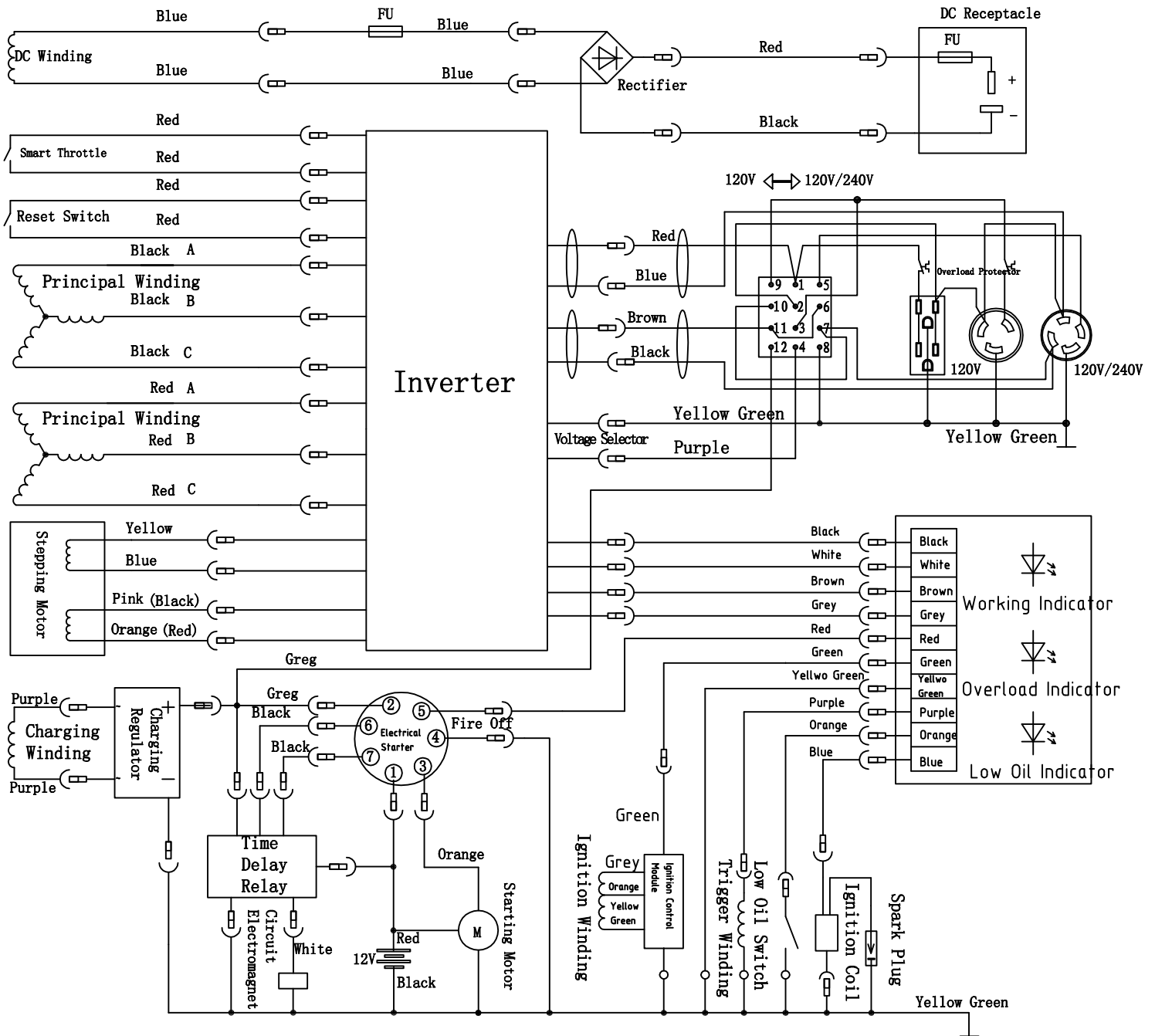

	①	②	③	④	⑤	⑥	⑦
OFF				● — ●	● — ●	● — ●	● — ●
ON	● — ●	● — ●					
START	● — ●	● — ●	● — ●				

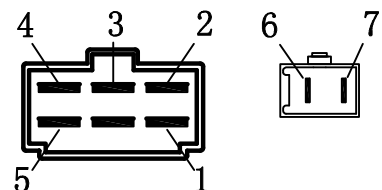

---

## 12. WHEEL KIT

---

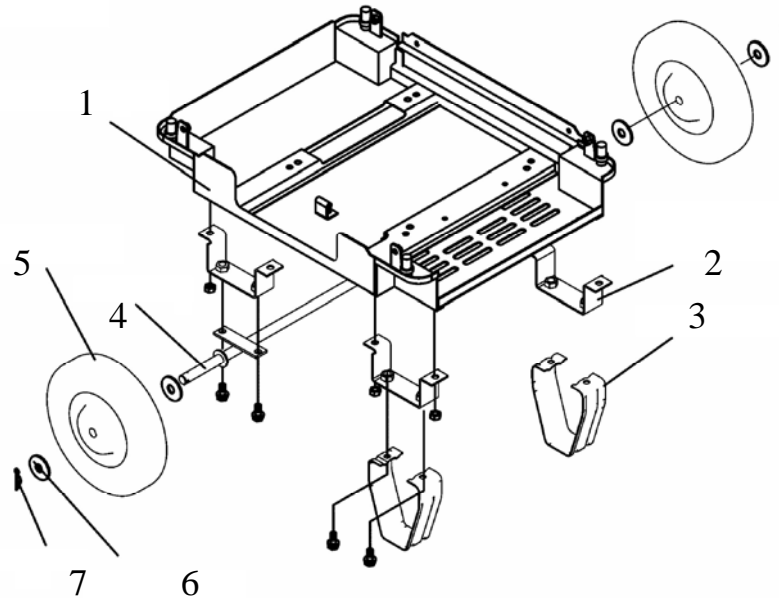

- |                         |                     |
|-------------------------|---------------------|
| 1. Chassis- installed   | 5. 10" Wheel        |
| 2. Support Bracket- (4) | 6. Wheel Washer (4) |
| 3. Front Stabilizer (2) | 7. Wheel Clip       |
| 4. Axle Assembly        |                     |

### Assembly:

1. Install the four support brackets and secure with bolts.
2. Attach the front stabilizers to the chassis (below the handles)
3. Attach the axle assembly.
4. Install one washer on the axle against each welded stop.
5. Install the two wheels.
6. Install the two remaining washers and secure with the wheel clips.

The handles are preassembled before packaging. To raise the handles, simply raise the handle assembly to a horizontal position. To retract the handles, slide the chrome collars toward you to clear the sleeve and lower them to the starting position.

Voltmaster is a Wanco brand. Voltmaster, Wanco, and the Voltmaster and Wanco logos are registered trademarks of Wanco Inc. All other trademarks are property of their respective owners.



**WANCO INC.**  
5870 Tennyson Street  
Arvada, Colorado 80003  
800-730-3927  
303-427-5700  
303-427-5725 fax  
**[www.voltmaster.com](http://www.voltmaster.com)**

©2015 Wanco Inc. All rights reserved.