

WINGCO[®] GENERATORS

An American Company

We produce our products in our 200,000ft² facility located in Le Center, Minnesota, equipped with modern engineering, fabrication and assembly capabilities.



Volt Meter

Large, 3" voltmeter ensures the proper output is reached.



PTO Shield

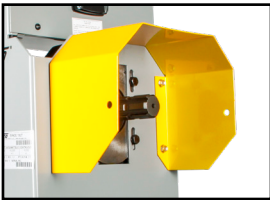

1 3/8" 6-Spline

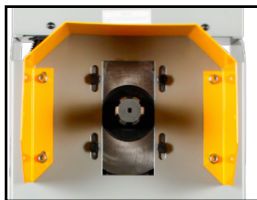

Receptacle Panel

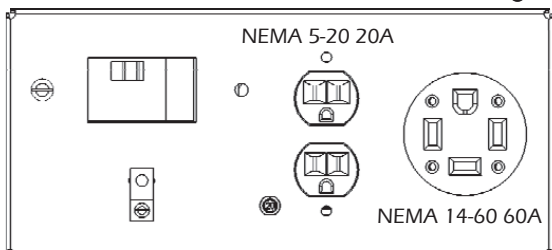

W15PTOS

15,000 WATTS

Rugged Design



Brushless Industrial Genend



SPECIFICATIONS

ELECTRICAL

MODEL NUMBER	VOLTS	STANDBY (125/40C)			CONTINUOUS (105/40C)			CIRCUIT BREAKER	MOTOR STARTING ⁽¹⁾
		WATTS	AMPS 1.0 PF	AMPS 0.8 PF	WATTS	AMPS 1.0 PF	AMPS 0.8PF		
W15PTOS-3	120/240 1-PH	15,000	62.5	N/A	13,000	54	N/A	60A	5 HP

(1) Code G capacitor motor.

W15PTOS-3

PTO INPUT SPEED	515 RPM
INPUT SHAFT SIZE	1 3/8" - 6 SPLINE
REQUIRED INPUT HP ⁽¹⁾	30
VOLTMETER	STANDARD
NEUTRAL BONDED	YES
GROUND LUG	YES
GEARCASE OIL	SAE 85W-90-140
GEARCASE CAPACITY	1 PINT

NOTES: (1) Required HP at PTO of tractor for full rated power. Each 2 HP equals approximately 1kW of electric power.

OPTIONAL ACCESSORIES

PTO SHAFT	1 3/8" 6-SPLINE
PTO TRAILER	TDM76
THREE POINT HITCH	TPH250
MANUAL TRANSFER SWITCH	VARIOUS

SHIPPING

SHIPPING DIMENSIONS (L x W x H)	37" x 16" x 25"
SHIP WEIGHT	234 LBS
FREIGHT CLASS	65

GEN END

LEAD	4 LEAD
WINDING	DEDICATED
VOLTAGE REGULATOR	CAPACITOR
VOLTAGE REGULATION	+/- 5%
TOTAL HARMONIC DISTORTION	< 5%
GENERATOR SPEED	3600 RPM
INSULATION PROTECTION	CLASS H IP23
BRUSHLESS	YES
EFFICIENCY PEAK 1.0 PF	80.3
120 VOLT RECEPTACLES	(2) NEMA 5-20 20A
240 VOLT RECEPTACLES	(1) NEMA 14-60 60A
60A FULL POWER PLUG	INCLUDED
ASSEMBLED IN	USA
UNIT WARRANTY ⁽¹⁾	1 YEAR

NOTES: (1) For more generator warranty, see operator's manual.

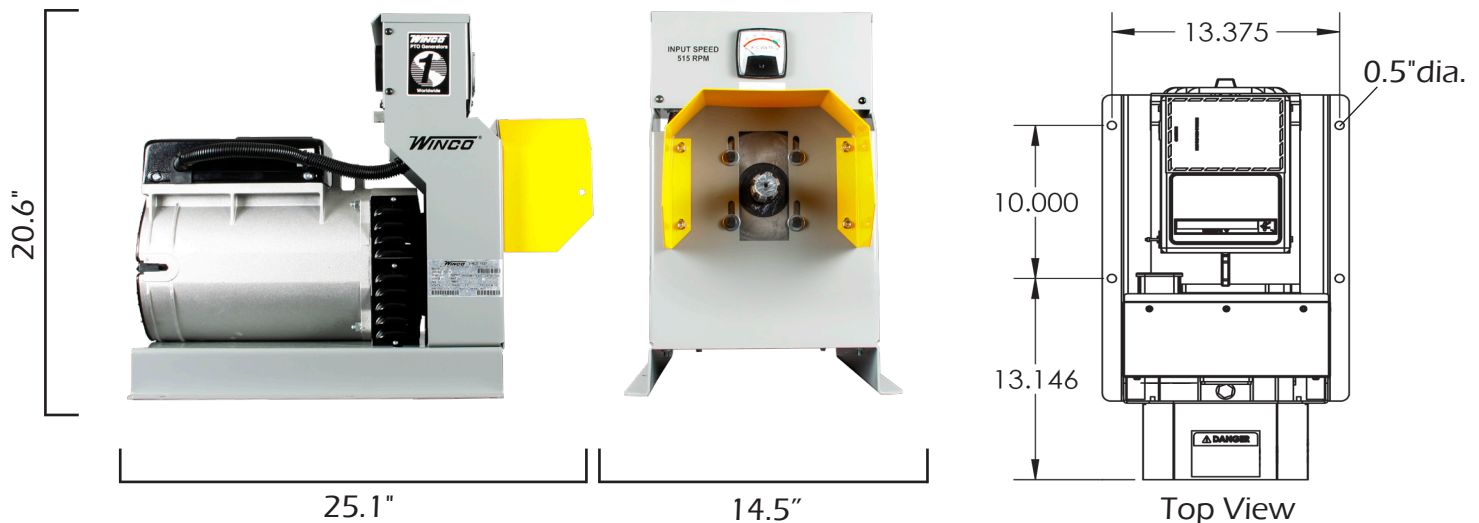

Specifications are subject to change without notice.

