



---

## OWNER'S AND OPERATOR'S MANUAL

---

# Diesel Engine Generator DGK14F

Vertical, Water-Cooled 4-Cycle Diesel Engine

### California Proposition 65



#### **WARNING**

Breathing diesel engine exhaust exposes you to chemicals known to the State of California to cause cancer and birth defects or other reproductive harm.

- Always start and operate the engine in a well ventilated area.
- If in an enclosed area, vent the exhaust to the outside.
- Do not modify or tamper with the exhaust system.
- Do not idle the engine except as necessary.

For more information go to [www.P65warnings.ca.gov/diesel](http://www.P65warnings.ca.gov/diesel).



#### **WARNING**

Cancer and reproductive Harm-  
[www.P65Warnings.ca.gov](http://www.P65Warnings.ca.gov)



#### **WARNING**

Batteries, battery posts, terminals and related accessories contain lead and lead compounds, and other chemicals known to the State of California to cause cancer and birth defects or other reproductive harm. WASH HANDS AFTER HANDLING.



#### **CAUTION**

Do not operate the Generator, or any other appliance, before you have read and understood the instructions for use and keep near for ready use.





## Introduction

Thank you for purchasing this Shindaiwa soundproof diesel engine generator.

- This manual has been created to ensure safe usage of this generator. Be sure to read this manual before operation. Improper operation/handling of this generator will result in an accident or malfunction.
- Handling/Operation of this generator can only be performed by persons who understand the contents of this manual and can handle/operate the generator in a safe manner. Persons who suffer from an illness, are taking medicine or not feeling well such that safe operation would be negatively affected must not operate this generator.
- Work performed using this generator and handling/operation of this generator must be in accordance with corresponding laws and regulations based on such laws. Consult with the authorized distributor where this generator was purchased if you have any inquiries regarding the corresponding laws.
- Always be sure to include this manual when loaning out this generator and instruct operating personnel to read this manual before operation.
- Store this manual in a specified location where it will be secure and available for consulting at any time. Order another copy from the authorized distributor where this generator was purchased if this manual becomes dusty, grimy or torn.
- Consult with the authorized distributor where this generator was purchased if you have any inquiries regarding any points related to this generator and manual.  
When inquiring about this generator, be sure to provide the model name and serial number.
- If disposing of this generator, do so in a manner that is in compliance with laws related to industrial waste. Contact the authorized distributor where the generator was purchased if you have any inquiries regarding proper disposal.

■ Caution notice ranks in this manual are classified as follows.

 **WARNING:** Indicates a potentially hazardous situation which, if not avoided, can result in death or serious injury.

 **CAUTION :** Indicates a potentially hazardous situation which, if not avoided, can result in minor or moderate injury and property damage.

**< Note > :** Other types of cautions and indications.

- Note that  **CAUTION** items can also lead to major accidents under some circumstances if not correctly followed.  
All caution notices are important. Be sure to follow all of them.

## Table of Contents

<b>1. Safety Instructions</b> .....	<b>2</b>
<b>2. Specifications</b> .....	<b>6</b>
2-1. Specifications .....	6
2-2. Ambient Conditions .....	7
<b>3. Applications</b> .....	<b>7</b>
<b>4. Part Names</b> .....	<b>7</b>
4-1. External View/Part Names .....	7
4-2. Operation Panel Configuration .....	9
<b>5. Equipment</b> .....	<b>10</b>
5-1. Available Output Monitor .....	10
5-2. Spill Containment .....	10
5-3. Warning Indicators .....	11
5-4. Spill Containment Overflow Warning Indicator .....	13
5-5. Meters and Gauges.....	13
5-6. Fuel Piping Switch (3Way Fuel Valve).....	16
<b>6. Transport/Installtion</b> .....	<b>16</b>
6-1. Transport Procedures.....	16
6-2. Installation Procedures.....	17
<b>7. Load Connections</b> .....	<b>18</b>
7-1. Load Cable Selection .....	18
7-2. Connecting Load Cables .....	19
<b>8. Pre-Operation Inspection</b> .....	<b>20</b>
8-1. Checking Engine Oil.....	20
8-2. Checking Coolant.....	21
8-3. Checking the Fuel .....	22
8-4. Checking the Spill Containment .....	22
8-5. Checking for Fuel, Oil and Coolant Leaks .....	23
8-6. Checking the Battery .....	23
<b>9. Oprating Procedures</b> .....	<b>24</b>
9-1. Initial Startup/Pre-Check.....	24
9-2. Procedures during Operation .....	26
9-3. Stopping Operation .....	27
9-4. Protective Functions.....	27
9-5. Connecting with External Fuel Tank .....	29
<b>10. Inpection/Maintenance</b> .....	<b>30</b>
<b>11. Long-Term Storage</b> .....	<b>39</b>
<b>12. Troubleshooting</b> .....	<b>41</b>
<b>13. Generator Circuit Diagram</b> .....	<b>44</b>
<b>14. Engine Electrical Circuit Diagram</b> .....	<b>45</b>

## 1. Safety Instructions

### **WARNING : EXHAUST GAS POISONING**

- Do not operate the generator in poorly ventilated areas such as indoors or tunnels, as the exhaust gas of the engine contains substances that are harmful to human health.
- Do not direct exhaust fumes at bystanders or buildings.

### **WARNING : ELECTRIC SHOCK**

- Do not operate the equipment with any doors or covers open.
- Always turn all the breakers OFF, place the starter switch in the STOP position and stop the engine before connecting / disconnecting the load cable to the output terminal or receptacle.
- Close the receptacle cover before operating.
- Do not insert a pin, wire or other metal object into the electrical outlet.
- Do not touch the generator if the generator or casing or your body becomes wet during operation.
- Do not touch internal electric parts while the generator is operating.
- Always turn the starter switch to the STOP position and stop the engine, then close and lock OPERATION PANEL DOOR before checking or maintaining the engine or any equipment.

### **WARNING : INJURY**

- Close all doors and lock them during operation.
- Do not open the check door when the starter switch is in the AUTO or START position. It will cause injury by rotating parts such as cooling fans and fan belt.
- Always turn the starter switch to the STOP position and stop the engine, then close and lock OPERATION PANEL DOOR before checking or maintaining the engine or any equipment.
- Use the lifting hook to lift the machines, and do not lift up by using tie downs. Use of such could result in the generator falling.
- Do not lift any additional weight such as fuel tanks or trailers.
- No persons should ever be under a lifted generator.
- Always be sure to check that the breakers on load side and switches for any equipment using the generator are at OFF before turning the breaker to ON. Also be sure to advise personnel on the load side that power will be turned on or off before operating the breaker.
- Do not modify the equipment and do not operate with parts removed.

### **CAUTION : EYE/SKIN INJURY**

- Wear rubber gloves and other protective wear to protect eyes, skin and clothing from the battery fluid which contains diluted sulfuric acid. If the battery fluid contacts eyes or skin, wash out immediately with a sufficient amount of clean water. Be sure to receive medical treatment, especially if the fluid contacts the eyes.

**⚠ CAUTION : EXPLOSION** 

- Never use or recharge the battery if the fluid level is below the minimum level.
- Do not create sparks or bring flame near the battery as it generates flammable gas.

**⚠ CAUTION : FIRE** 

- Do not carry flammable items (such as fuel, gas and paint) or items that are highly combustible near the generator as the muffler, exhaust gas and other parts become extremely hot.
- Position this generator 3 ft. (1 m) or more from walls or other hindrances, and on a level surface.
- Do not connect the generator output to indoor wiring.
- This generator uses diesel fuel. Always be sure to stop the engine and not bring flames close when inspecting fuel or refueling. Wait until the engine has cooled before performing such procedures.
- If fuel spills, always be sure to open the spill containment drain valve and drain off the spilled fuel.
- Do not operate the equipment with liquid accumulated in the spill containment.
- If fuel or oil leaks, repair the leaking location before operating.
- Always be sure to wipe up any spilled fuel or oil.
- Allow the generator to cool before covering with the protective cover.
- Never allow flame to come close to the generator.
- Always make sure that the engine is stopped when working on piping.
- After working on the piping, check that there is no fuel leakage.
- Absolutely never inspect or perform maintenance to the equipment near fire or other open flame.

**⚠ CAUTION : ELECTRIC SHOCK** 

- Do not sprinkle water on the equipment and do not use where exposed to rain.

**⚠ CAUTION : BURNS** 

- Do not touch the engine and surrounding components immediately after stopping the engine as they are still extremely hot.
- Do not open the radiator cap immediately after stopping the engine. Doing so will result in hot steam gushing out.
- Hot steam gushes out from the coolant sub-tank if the generator overheats. Do not touch the coolant sub-tank.
- Always be sure to stop the engine and allow the engine to cool when performing inspection or maintenance of engine oil. Opening the oil level gauge or oil filler cap during operation will result in hot oil gushing out.

**⚠ CAUTION : INJURY** 

- Always be sure to use lifting hooks when lifting up the generator, and slowly lift it straight up.
- Personnel performing lifting work must wear protective gears such as helmets, safety shoes and gloves.
- Remove the wood ties if using anchors to secure the generator.
- Position the generator on a level stable surface so that it cannot slide or move in any manner.
- Before starting operation, always be sure to turn off all switches of equipment using the generator and all breakers to OFF.
- Do not move the generator during operation.
- Do not operate the generator if it has been modified or any parts have been removed.
- Securely fix the equipment with rope or similar item so that it cannot move when transporting by truck or other vehicle.

**⚠ CAUTION : PROPERTY DAMAGE**

- Do not use the equipment for any improper applications. Improper usage can result in an accident or malfunction.
- If using this generator for medical equipment, check before use with the medical equipment manufacturer, doctor, hospital or similar entity.
- Check that the generator output setting, receptacle connection and load power source are consistent.
- Cable burnout can occur due to generated heat if the load current exceeds the allowable current of the cable.
- The voltage drop between cables is large if the cable is excessively long or thin, resulting in decreased input voltage to equipment using the generator, thereby causing decreased performance, faulty operation and malfunction.

■ Warning /Caution Label Locations

If warning or caution labels become damaged and difficult to read, replace with new labels in the indicated locations. Order labels using part number indicated in the parenthesis.

- |   |                                 |                        |
|---|---------------------------------|------------------------|
| ① | Caution: GM SPEC LLC            | Part no. : X505-007840 |
| ② | Warnig: Fire                    | Part no. : X505-007650 |
| ③ | Caution: Burn                   | Part no. : X505-007830 |
| ④ | Warnig: caution                 | Part no. : X505-010910 |
| ⑤ | Warnig: Injury                  | Part no. : X505-007550 |
| ⑥ | Bonnet grounding terminal       | Part no. : M704-001400 |
| ⑦ | Spill containment bolt          | Part no. : M707-000380 |
| ⑧ | EPA regulation complied notice  | Part no. : X505-008400 |
| ⑨ | Caution                         | Part no. : X505-010800 |
| ⑩ | Warning: Proposition 65 Gen     | Part no. : X505-010400 |
| ⑪ | Warning: Proposition 65 Battery | Part no. : X505-010410 |
| ⑫ | Warning: Injury                 | Part no. : X505-010920 |

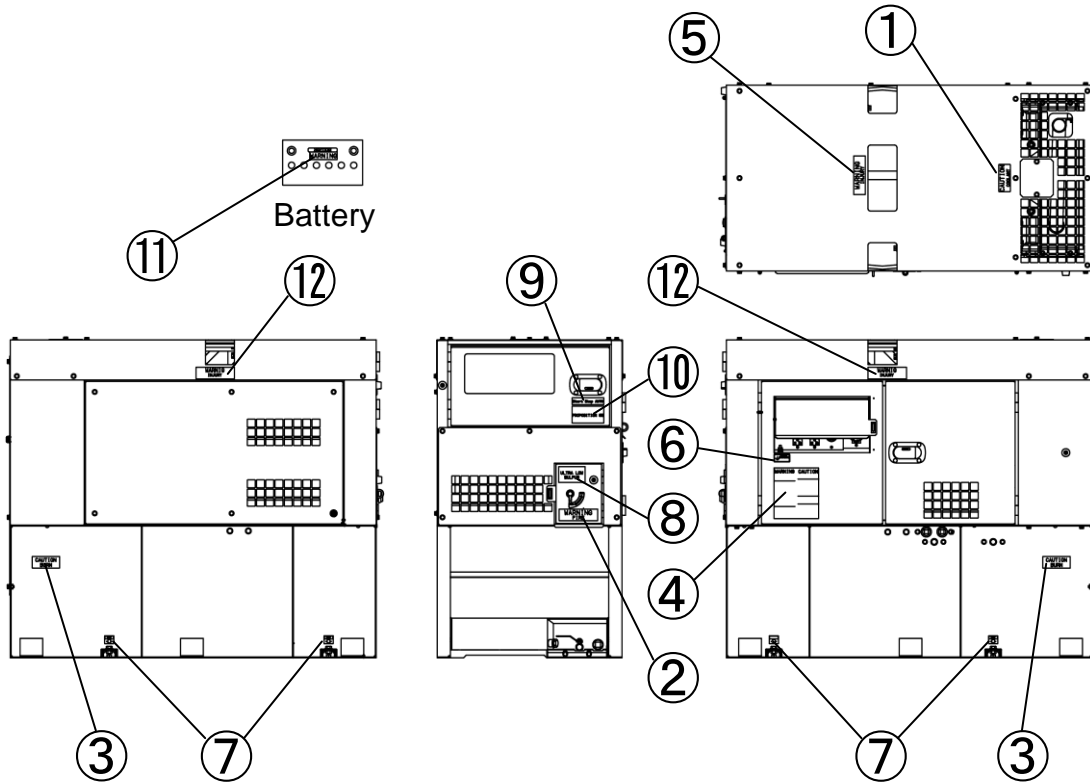



## 2. Specifications

### 2-1. Specifications

Model		Unit	DGK14F
Alternator	Generator Type	-	Revolving Field Brushless
	Armature Connection	-	ZigZag-W
	Rated Frequency	Hz	60
	Rated Output(Prime)	kVA	14
		kW	14
	Standby Output	kVA	14.7
		kW	14.7
	Rated Voltage	V	240/120
	Rated Current	A	58.3
	Phase		Single phase
	Power Factor	-	1.0
	Insulation class	-	F
Excitation	-	Self Excitation (brushless)	
No. of Poles	-	4	
Engine	Type	-	Vertical Water-Cooled 4-Cycle Diesel
	Model(Manufacturer)	-	Kubota D1503
	No. of Cylinders (bore x stroke)	(in./mm)	3(3.27×3.64/83×92.4)
	Continuous Rated Output	hp	19.5
	Rated Speed	rpm	1800
	Displacement	cu.in./liters	91.5/1.499
	Combustion System	-	Indirect Injection
	Cooling Method	-	Radiator
	Lubricating Method	-	Forced Lubrication
	Starting Method	-	Electric
	Fuel	-	No.2-D,S15 EPA regulation
	Lubricating Oil	-	CF class
	Fuel Tank Capacity	gal./liters	34.3/130
	Lubricant Volume	gal./liters	1.9/7.3 (including filter 0.1/0.3)
	Cooling Water Volume	gal./liters	2.3/8.8 (including sub-tank 0.3/1.1)
	Starting Motor Capacity	V-kW	12-1.4
Charging Alternator Capacity	V-A	12-30	
Battery Capacity	V-Ah	12-55	
Unit	Length	in./mm	55/1390
	Width	in./mm	28/704
	Height	in./mm	47/1204
	Dry Weight	lbs./kg	1378/625
	Net Weight	lbs./kg	1669/757

## 2-2. Ambient Conditions

Use this generator in ambient conditions as described below. Failure to provide these conditions can result in problems such as malfunction, insufficient output and reduced durability.

- Ambient temperature: 5 to 104 °F (-15 to 40 °C)
- Relative humidity: 85% or less
- Altitude: 984 ft. (300 m) or less

## 3. Applications

- Power source for submerged pumps and similar civil engineering equipment
- Power source for lighting and similar equipment
- Power source for electrical tools and household appliances

### **⚠ CAUTION : PROPERTY/SECONDARY DAMAGE**

- Do not use for any application other than those listed above.
- If using this generator for medical equipment, check before use with the medical equipment manufacturer, doctor, hospital or similar entity.

## 4. Part Names

### 4-1. External View/Part Names

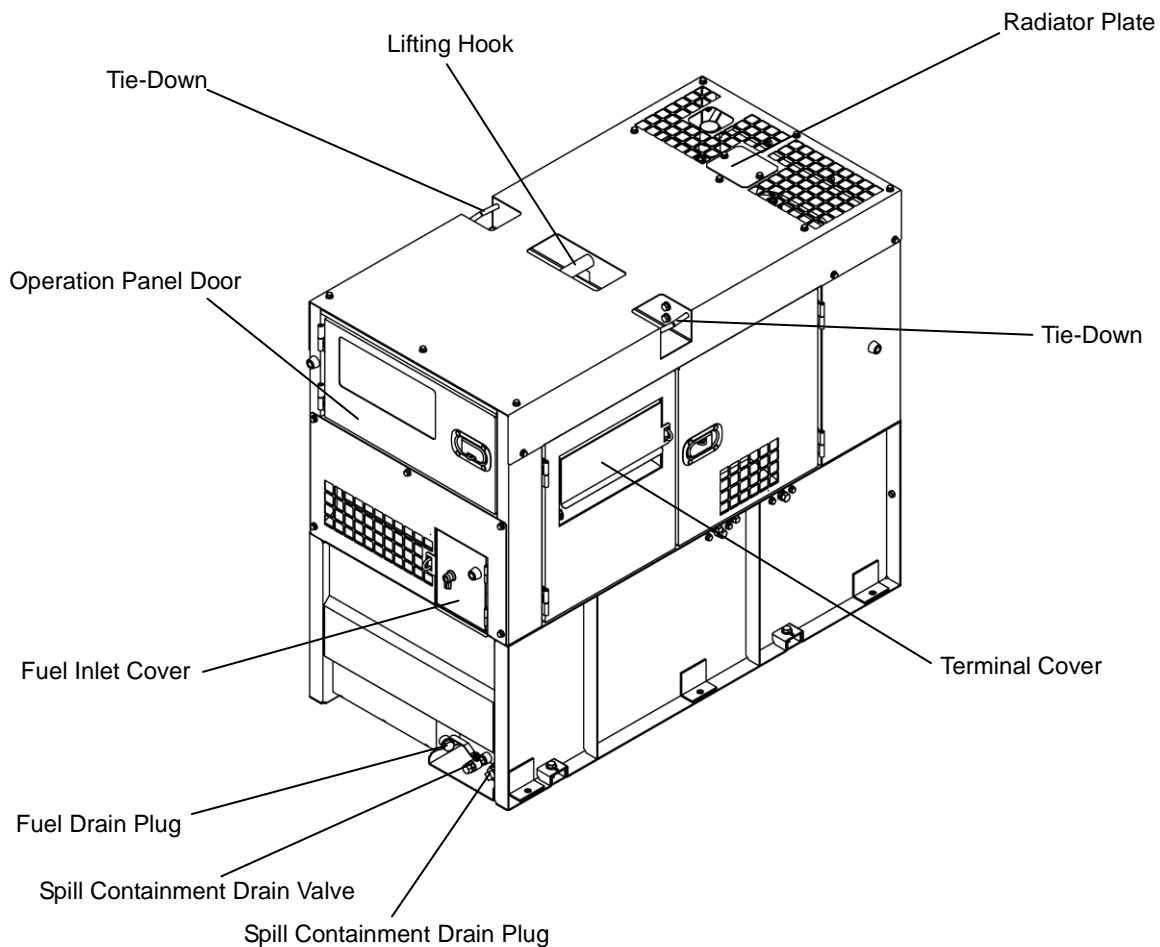

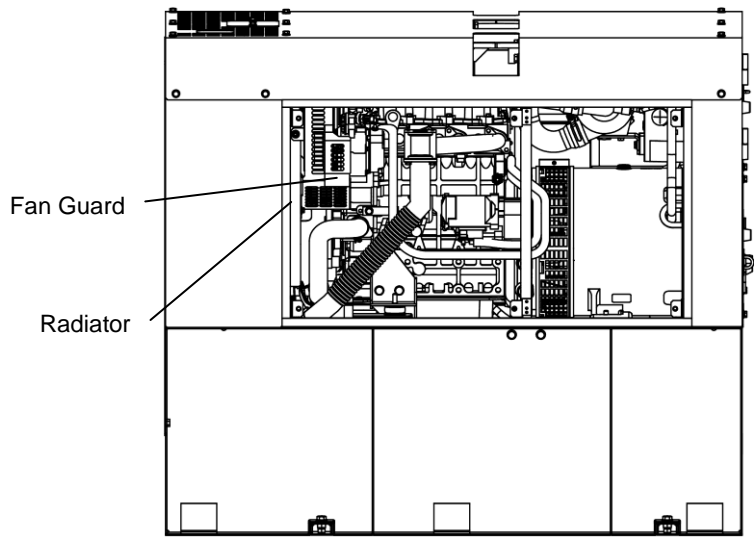

\* Shown with side-plate removed.

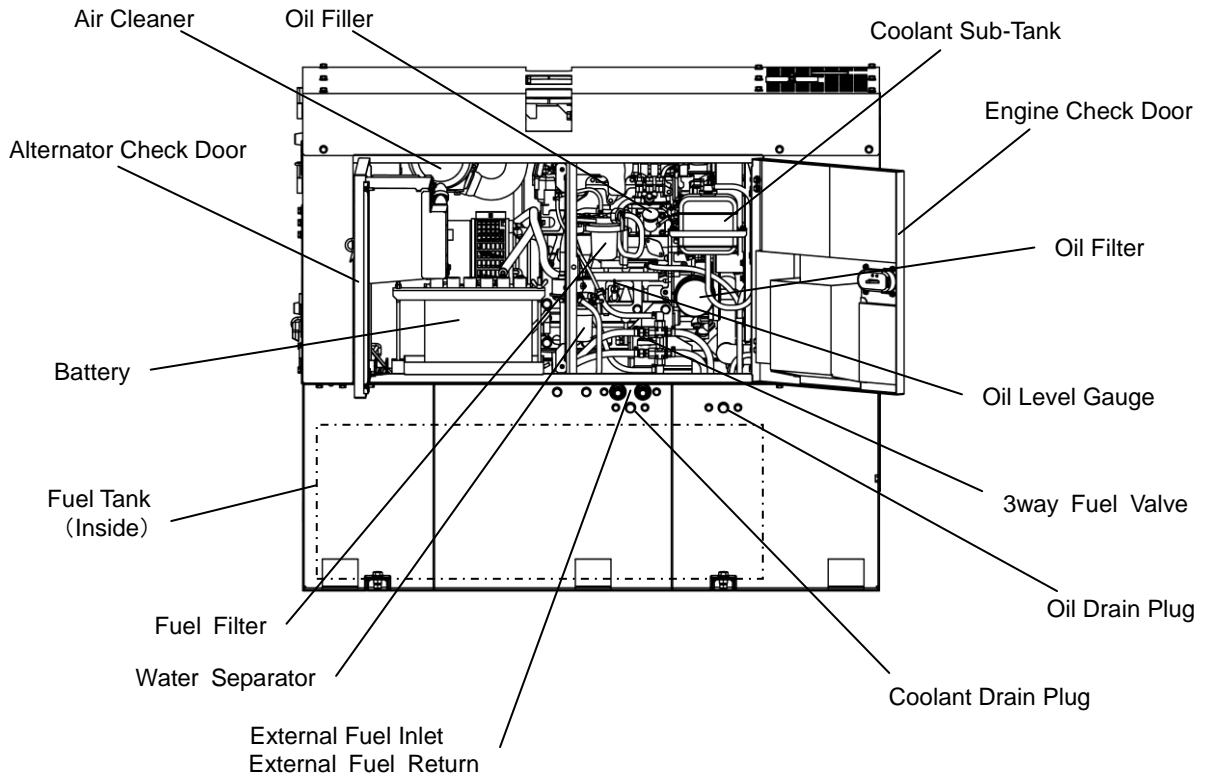

Accessories

Owner's  
and  
Operator's  
Manual

Engine  
Warranty  
Manual

## 4-2. Operation Panel Configuration

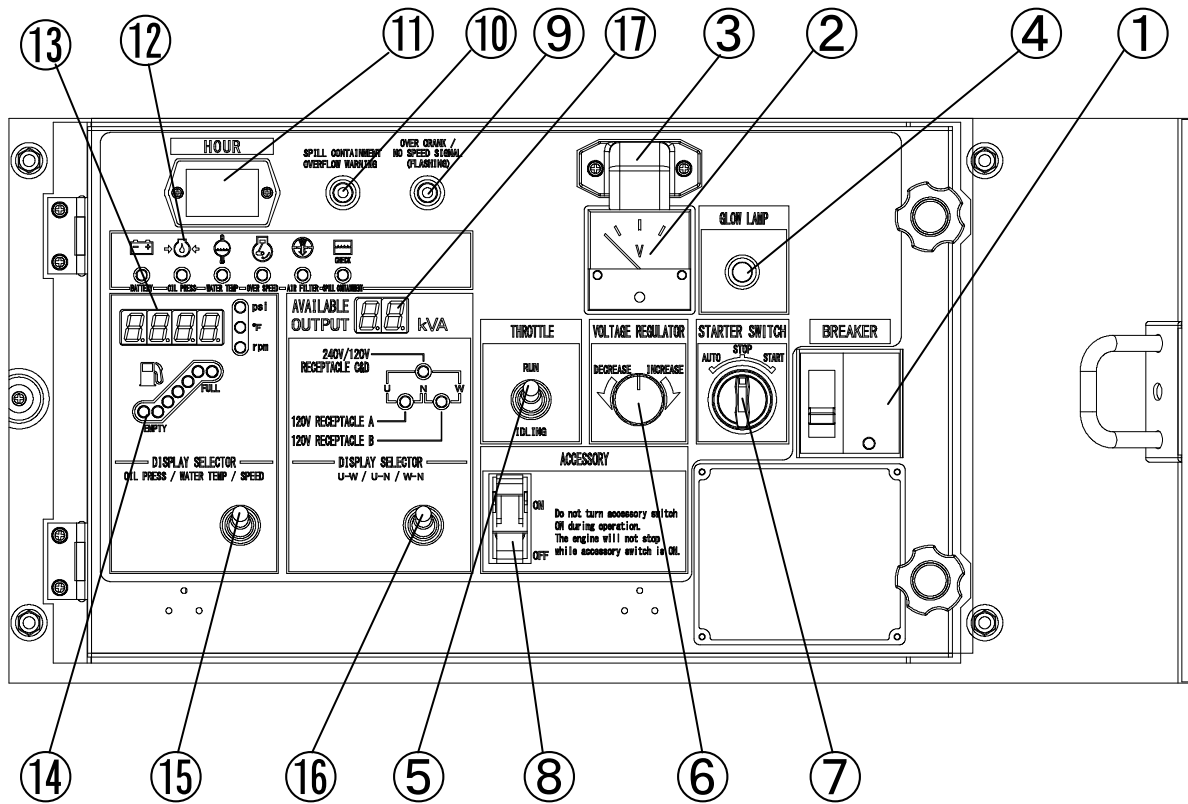

①	Main Circuit Breaker	⑪	Hour Meter
②	Voltmeter	⑫	Warning Indicators
③	Pilot Lamp	⑬	Engine Monitor
④	Glow Lamp	⑭	Fuel Meter
⑤	Throttle Switch	⑮	Oil Pressure/ Water Temperature / Speed Selector Switch
⑥	Voltage Regulator	⑯	Display Selector Switch
⑦	Starter Switch	⑰	Available Output Monitor
⑧	Accessory Switch		
⑨	Over Crank / No Speed Signal Indicator		
⑩	Spill containment Overflow Warning Indicator		

## 5. Equipment

### 5-1. Available Output Monitor

The available generated output for each output power source is displayed digitally. You can use the display selector switch to change the display in the following order: Total output of 240V Receptacle and 240/120V Receptacle, 120V Receptacles output. Total output of 240V Receptacle and 240/120V Receptacle is always displayed when the engine is started.

#### < Note >

- Consider the digitally displayed available output as an approximate estimate. Be sure to thoroughly consider the displayed value and the used load capacity when using a load such as a motor with large starting capacity.
- If “-” is displayed for the available output, it means that usage has exceeded the rated capacity. Immediately stop the equipment being used and reduce the load capacity of the equipment.

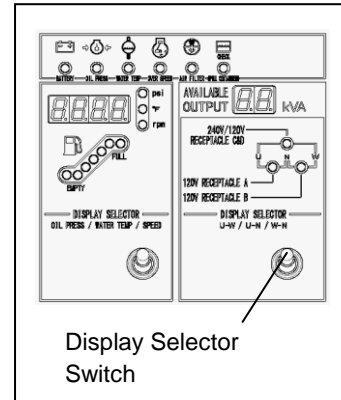

### 5-2. Spill Containment

#### **WARNING : INJURY**

- Do not open the check door when the starter switch is in the AUTO or START position. It will cause injury by rotating parts such as cooling fans and fan belt.
- Always turn the starter switch to the STOP position and stop the engine, then close and lock OPERATION PANEL DOOR before checking or maintaining the engine or any equipment.

#### **CAUTION : BURNS**

- Do not touch the engine and surrounding components immediately after stopping the engine as they are still extremely hot.

#### **CAUTION : FIRE**

- If fuel or oil leaks, repair the leaking location before operating.

The bed of this generator is equipped with a spill containment (structure for preventing leakage of liquids) so that any spilled liquid will not leak to outside of the generator when oil or fuel is spilled or leaks. Before starting operation, check if there is accumulated liquid in the spill containment. Flush out any liquid that has accumulated.

(Refer to section “8-4. Checking the Spill Containment” for inspection procedures. )

(Refer to section “10. Inspection/Maintenance (9) Flushing Liquid in Spill Containment” for flushing procedures. )

The generator is equipped with the following in order to prevent liquid from spilling in case you forget to flush the liquid: The operation panel is equipped with an indicator that illuminates when its sensor is triggered as the spill containment capacity accumulated enough liquid to reach to about 4.5gal(17 liters).

If the liquid stored in the spill containment exceeds approximately about 13.4gal(51 liters) during operation, the SPILL CONTAINMENT overflow warning indicator illuminates, and the engine will be automatically stopped. If this occurs, flush the liquid stored in the spill containment.

(Refer to section “10. Inspection/Maintenance (9) Flushing Liquid in Spill Containment”.)

**< Note >**

- Water can also accumulate in the spill containment due to rain entering into the generator. Accordingly, you should periodically flush liquid accumulated within the generator. However, you should flush water according to the frequency/amount of rainfall.
- The types of liquids that can accumulate in the spill containment include oil, fuel, coolant and battery fluid such that it is not possible to distinguish between rainwater and other liquids. Dispose of flushed liquids according to the applicable laws and regulations.

**5-3. Warning Indicators**

**⚠ WARNING : INJURY** 

- Do not open the check door when the starter switch is in the AUTO or START position. It will cause injury by rotating parts such as cooling fans and fan belt.
- Always turn the starter switch to the STOP position and stop the engine, then close and lock OPERATION PANEL DOOR before checking or maintaining the engine or any equipment.

**⚠ CAUTION : BURNS** 

- Do not touch the engine and surrounding components immediately after stopping the engine as they are still extremely hot.

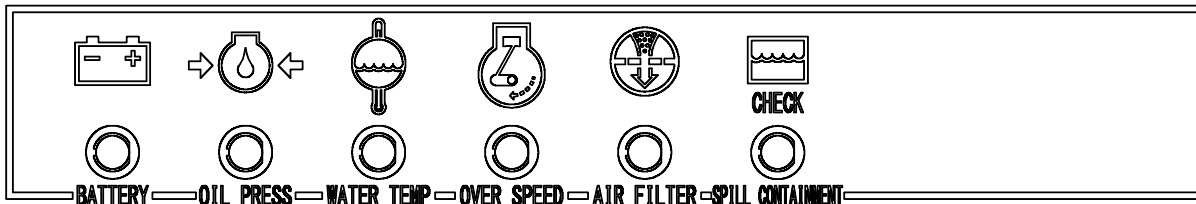

This generator is equipped with the following warning indicators: BATTERY (insufficient charging), OIL PRESS (engine oil pressure), WATER TEMP (coolant temperature), OVER SPEED (engine overspeed), AIR FILTER (air cleaner clogging), SPILL CONTAINMENT (spill containment amount). Selecting the starter switch from STOP to START position causes the BATTERY and OIL PRESS warning indicator to illuminate, and all indicator lights will go off as engine starts. An indicator illuminates if malfunction/fault occurs during operation and the engine automatically stops depending on the fault type (except for SPILL CONTAINMENT). If the generator automatically stops, set the starter switch to STOP and restart the engine. Check each illuminated warning indicator at the time of automatic stop, and inspect the failed component.

**(1) BATTERY (Insufficient Charging) Warning Indicator (Low Battery Voltage)**

The BATTERY warning indicator illuminates and the engine automatically stops when charging is not possible during operation. If this occurs, contact authorized distributor where the generator was purchased.

**< Note >**

- This battery charging warning indicator cannot detect battery deterioration or insufficient battery fluid. (Refer to section “**8-6. Checking the Battery**”).

## (2) OIL PRESS (engine oil pressure) Warning Indicator (Low Oil Press.)

### **CAUTION: BURNS**

- Always be sure to stop the engine and allow the engine to cool when performing inspection or maintenance of engine oil. Opening the oil level gauge or oil filler cap during operation will result in hot oil gushing out.

If the engine oil pressure drops below 7 psi (0.49 x 100 kPa) during operation, the OIL PRESS warning indicators illuminates, and the engine will be automatically stopped. If this occurs, check the engine oil level and add engine oil until it reaches the maximum level.

### < Note >

- This oil pressure warning indicator cannot detect oil deterioration. Change the engine oil periodically. (Refer to section “8-1. Checking Engine Oil”.)

## (3) WATER TEMP (Coolant Temperature) Warning Indicator (High Water Temp.)

### **CAUTION: BURNS**

- Do not open the radiator cap immediately after stopping the engine. Do so will result in hot steam gushing out.
- Hot steam gushes out from the coolant sub-tank if the generator overheats. Do not touch the coolant sub-tank.

If the coolant temperature rises above 239 °F(115°C) during operation, the WATER TEMP warning indicators illuminate, and the engine will be automatically stopped. If this occurs, hot steam will gush out of the coolant sub-tank. Check the coolant sub-tank coolant level after the generator cools and add coolant to the coolant sub-tank if it is insufficient. (Refer to section “8-2. Checking Coolant”.) If the coolant is at the specified amount, it is probable that the fan belt is loose or there is a coolant leak. Wait for the engine to cool down and inspect for these problems.

### < Note >

- The coolant temperature cannot be detected if the coolant level is excessively low. Always be sure to check the coolant level in the radiator coolant sub-tank before starting operation.

## (4) OVER SPEED (Engine Overspeed) Warning Indicator

This generator is equipped with a function such that the engine is automatically stopped if an engine fault occurs causing the engine speed to increase excessively. If the engine speed rose above 2070rpm during operation, the OVER SPEED warning indicators illuminates, and the engine will be automatically stopped. If this occurs, it is probable that some malfunction has occurred in the engine. Contact authorized distributor where the generator was purchased.

## (5) AIR FILTER (Air Cleaner Clogging) Warning Indicator

The AIR FILTER warning indicator illuminates if the air cleaner element becomes clogged during operation. If it illuminates, immediately stop the engine and clean or replace the air cleaner element. (Refer to section “10. Inspection/Maintenance (3) Air Filter Element Cleaning/Replacement”.)

## (6) SPILL CONTAINMENT (Spill Containment Amount) Checking Indicator

The SPILL CONTAINMENT checking indicator illuminates if the liquid stored in the spill containment exceeds approximately about 4.5gal(17 liters) during operation. If it illuminates, immediately stop the engine and flush the liquid stored in the spill containment.

(Refer to section “10. Inspection/Maintenance (9) Flushing Liquid in Spill Containment”.)

### < Note >

- The engine may not be stopped only if the spill containment checking indicator illuminates during operation.
- When the spill containment checking indicator illuminates during operation, stop the engine, check for fuel, oil and coolant leakage, and repair as necessary.
- Do not use the equipment with liquid accumulated in the spill containment. Drain the spill containment before using.

## 5-4. Spill Containment (Spill Containment Amount) Overflow Warning Indicator



### WARNING : INJURY



- Do not open the check door when the starter switch is in the AUTO or START position. It will cause injury by rotating parts such as cooling fans and fan belt.
- Always turn the starter switch to the STOP position and stop the engine, then close and lock OPERATION PANEL DOOR before checking or maintaining the engine or any equipment.



### CAUTION : BURNS



- Do not touch the engine and surrounding components immediately after stopping the engine as they are still extremely hot.



### CAUTION : FIRE



- If fuel or oil leaks, repair the leaking location before operating.

If the liquid stored in the spill containment exceeds approximately about 13.5gal(51 liters) during operation, the SPILL CONTAINMENT overflow warning indicator illuminates, and the engine automatically stops. If this occurs, flush the liquid stored in the spill containment.

(Refer to section “10. Inspection/Maintenance (9) Flushing Liquid in Spill Containment”.)

### < Note >

- Although the fluids that can leak internally consist of oil, fuel and coolant, the spill containment does not have a function that can separate rainwater that has leaked into the equipment from these internally leaked fluids. Properly dispose of liquid drained from the spill containment in a manner according to the applicable laws and regulations.

## 5-5. Meters and Gauges

### Engine Meters and Gauges

#### (1) Hour Meter

Displays the operating time. Use this as a reference for managing periodic inspection interval.

#### (2) Engine Monitor

Displays the engine speed, coolant temperature and oil pressure. Switching the selector switch changes the display in the following order: Speed → Water temp → Oil press. Engine speed is displayed first when the engine is started.



- ① Speed  
Displays the engine speed. 1800rpm is displayed at 60 Hz.
- ② Water Temp  
Displays the temperature of the engine coolant. Normal temperature displayed during operation should generally between 158°F (70°C) and 203°F (95°C) depending on usage.

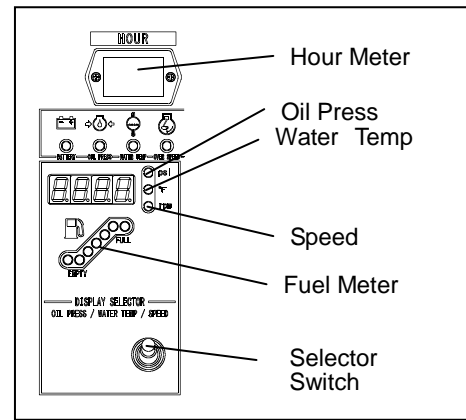

**< Note >**

- If the coolant temperature rises above 212°F (100°C), immediately stop all connected equipment to the generator, and idle the engine while cool down the coolant temperature.

- ③ Oil Press  
Displays the pressure of the engine lubrication system. Normal pressure displayed during operation should generally 35 and 57 psi (2.4–3.9 x 100 kPa) depending on usage. However, the pressure may rise above this range just after starting a cold engine. Idle the engine until it reaches the normal pressure.

**(3) Fuel Meter**

It shows the amount of fuel in the tank.

All lamps are lit when the amount reaches to the maximum level, and FULL is lit. decreases .The lit lamp decreases as the amount of fuel in the tank reaches to EMPTY. The fuel level on the control panel will only display the fuel level for the internal fuel tank.

**Generator Meters and Gauges**

**(1) Voltmeter**

The voltmeter displays the single-phase output voltage(voltage between U-W). Check that 240V at 60Hz is displayed during operation.

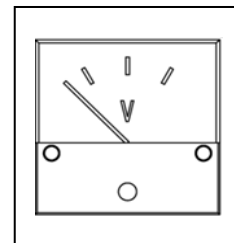

**Indicators**

**(1) Glow Lamp**

This lamp illuminates when the starter switch is on START position. This lamp turns off when pre-heating is completed. This lamp turns off and the generator starts.

**< Note >**

- Pre-heating completes in approximately 5 seconds.

**(2) Pilot Lamp**

This lamp illuminates when the engine is operating to indicate that power is being generated.

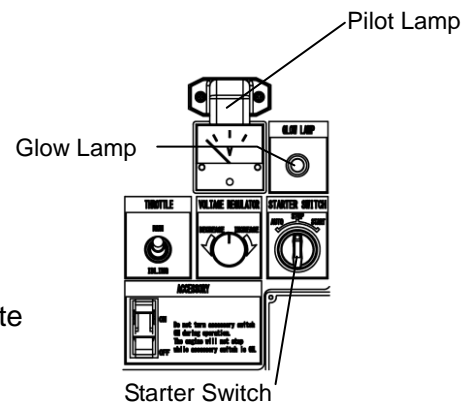

### (3) Over Crank / No Speed Signal Indicator

This indicator illuminates if the engine fails to start.

If that happens, set the "STARTER SWITCH" selector to STOP, and inspect the machine. (Refer to section "12. Troubleshooting.")

If this indicator starts flashing, the rotation signal has not been detected correctly. Contact the authorized distributor where the generator was purchased.

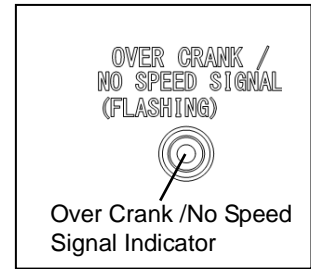

## Switches

### (1) Starter Switch

The engine warms up and starts automatically.

#### ① START

The engine is started in this position. The engine warms up and starts automatically.

#### ② STOP

The engine is stopped, and the power supply is turned off completely in this position. You can operate the ACCESSORY switch in this position.

#### ③ AUTO

The engine is started in this position when the REMOTE START terminal closes.

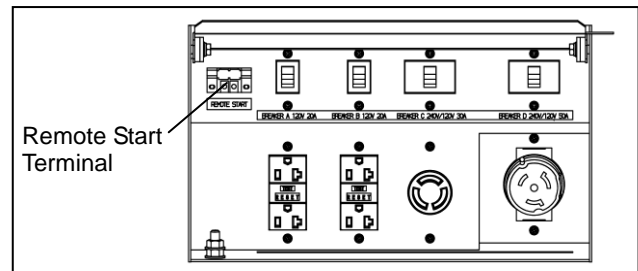
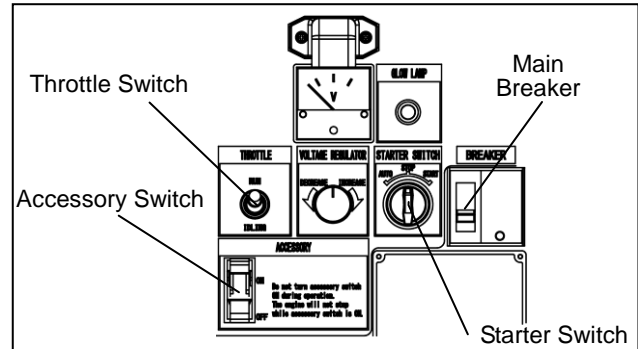

### (2) Accessory Switch

If you select ON, the display turns on, and you can check the fuel level.

#### < Note >

- Set the STARTER SWITCH selector to STOP to activate this function.
- Do not leave the ACCESSORY switch at ON position. This is causing battery from drain out.

### (3) Breaker

This switch is for transmitting electrical power to the load side. Turn to ON position to output voltage to the output receptacles. Output to the load side is cut off when there is a short circuit or overload on the load side.

#### < Note >

- Do not turns off/on the breaker manually to operate or stop a load.

## Voltage Regulator/Engine Speed Switch

### (1) Voltage Regulator

This dial is for regulating voltage output by the generator. Turn the dial clockwise to increase the voltage and counterclockwise to decrease it.

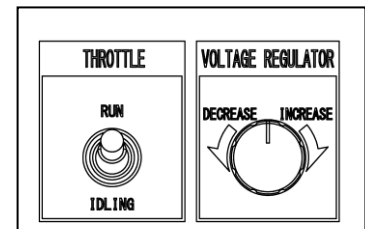

### (2) Throttle Switch

This switch is for changing the engine speed. Set to IDLING when starting, warming up and cool down the engine, and set to RUN during rated operation.

#### < Note >

- The engine is running at 1800rpm with 60Hz regardless of throttle switch position if you leave starter switch in AUTO position.

## 5-6. Fuel Piping Switch (3Way Fuel Valve)

### CAUTION:

- Always make sure that the engine is stopped when working on piping.
- Always be sure to wipe up any spilled fuel.
- After working on the piping, check that there is no fuel leakage.

Change the three-way fuel valve to switch to supply fuel from the external tank. In that case, the internal fuel tank is not used.

### (1) If using the internal fuel tank

Change the lever of the three-way fuel valve turned to the “A” side to supply fuel from the internal tank. It is turned to the “A” side when the generator is shipped from the factory.

#### < Note >

- When disconnecting piping from the external tank, turn the lever to the “A” side, and attach the bundled plug(R1/2”) to the external tank fuel inlet/return.

### (2) If using an external fuel tank

Connect hoses from the external fuel tank to the external fuel inlet and the external fuel return. Change the lever of the 3way fuel valve to the “B” side to supply fuel from the external tank.

Refer to “9-5. Connecting with External Fuel Tank” for corresponding procedures.

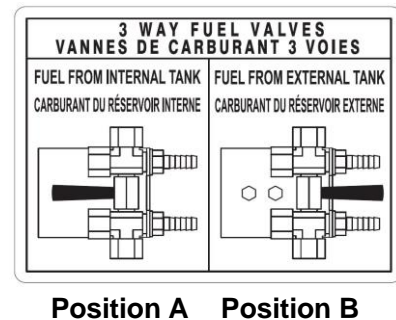
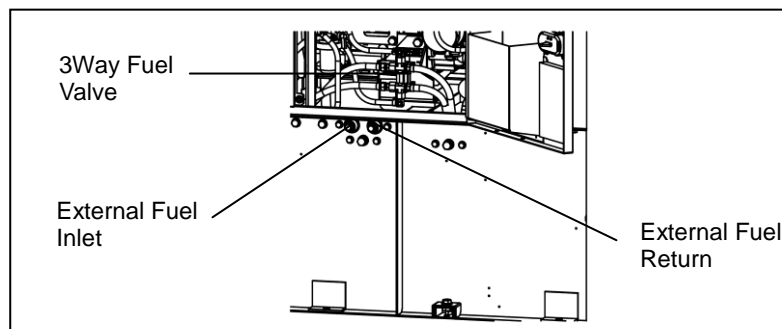

## 6. Transport/Installation

### 6-1. Transport Procedures

#### WARNING : INJURY

- Do not lift up the unit using tie down. Use of such could result in the generator falling.
- No persons should ever be under a lifted generator.

#### CAUTION : INJURY

- Always be sure to use lifting hooks when lifting up the generator, and raise it slowly at a completely vertical angle.
- Personnel performing lifting work must wear protective gears such as helmets, safety shoes and gloves.
- Do not move the generator during operation.

## (1) Lifting Procedures

Always be sure to use lifting hooks when lifting up the generator, and raise it slowly at a completely vertical angle.

## (2) Transport

When transporting this generator, tie rope to the left and right tie downs, and securely fix the generator.

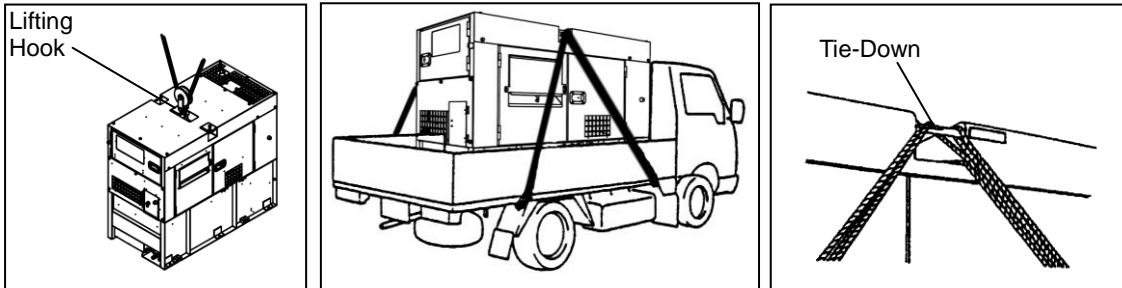

### < Note >

- Handle this generator with great care when raising, lowering and transporting. Rough handling of generator can result in damage or malfunction.

## 6-2. Installation Procedures

### **⚠ WARNING : EXHAUST GAS POISONING**

- Do not operate the generator in poorly ventilated areas such as indoors or tunnels, as the exhaust gas of the engine contains substances that are harmful to human health.
- Do not direct exhaust fumes at bystanders or buildings.

### **⚠ CAUTION : FIRE**

- Do not carry flammable items (such as fuel, gas and paint) or items that are highly combustible near the generator as the muffler, exhaust gas and other parts become extremely hot.
- Operate this generator 3 ft. (1 m) or more from walls or other hindrances, and on a level surface.
- Remove the wood ties if using anchors to secure the generator
- Do not connect the generator output to indoor wiring.

- If installing this generator, set up barriers or fencing completely around the boundary line of the construction area and take measures to prevent persons not involved in the construction from entering the area.
- Position this generator on a hard, flat and leveled surface.
- Position this generator 3 ft. (1 m) or more from walls or other hindrances so that the operation panel door and side-plate and check doors are accessible for internal inspection/maintenance.

**< Note >**

- This generator is manufactured presupposing that it will be installed on a flat, hard and leveled surface. Accordingly, care must be taken as using under any other installation conditions can result in a fault or malfunction.
- Do not place any objects where they will interfere with the radiator or muffler exhaust ports. Objects interfering with these ports will result in reduced engine output, overheating, and electrical component fault/malfunction.
- Operating the equipment in dusty or excessively salty location can result in a clogged radiator or overheating resulting in malfunction/fault or reduced insulation of electrical components. Be sure to thoroughly inspect and perform maintenance if using in such locations.

## 7. Load Connections

### 7-1. Load Cable Selection

**⚠ CAUTION : PROPERTY DAMAGE**

- Cable burnout could occur due to generated heat if the load current exceeds the allowable current of the cable.
- The voltage drop between cables is large if the cable is excessively long or thin, resulting in decreased input voltage to equipment using the generator, thereby causing decreased performance, faulty operation and malfunction.

Select cable for use that has sufficient thickness and an allowable current for use, and distance from the generator to the equipment using the generator.

**< Note >**

- Select cable with thickness ensures that the voltage drop across the cable would be within 5% of the rated voltage.

■ Load Cable Selection Tables

(Ex.) If used voltage is 120 V and voltage drops by 6 V.

Single-phase Cable cables

(Unit: AWG)

Current \ Length	200 ft (61 m) or less	300 ft (91 m)	400 ft (122 m)
10 A	10	8	8
20 A	8	6	4
30 A	6	4	2
50 A	4	2	1/0

## 7-2. Connecting Load Cables

### **⚠ WARNING : ELECTRIC SHOCK**

- Always turn all the breakers OFF, place the starter switch in the STOP position and stop the engine before attaching / detaching the load cable to the output terminal or receptacle.
- Close the receptacle cover before operating.
- Do not insert a pin, needle or other metal object into the electrical outlet.
- Do not touch the generator if the generator or casing becomes wet during operation.

### **⚠ CAUTION : FIRE**

- Do not connect the generator output to indoor wiring.

#### < Note >

- When connecting a load, check that the generator output setting, receptacle connection position, and load power source are all matching.
- Use proper tools when connecting a load to tighten properly. Failure to sufficiently tightened will result in cable burnout.

#### ■ Single-phase 120V receptacle, single-phase 240/120V receptacle

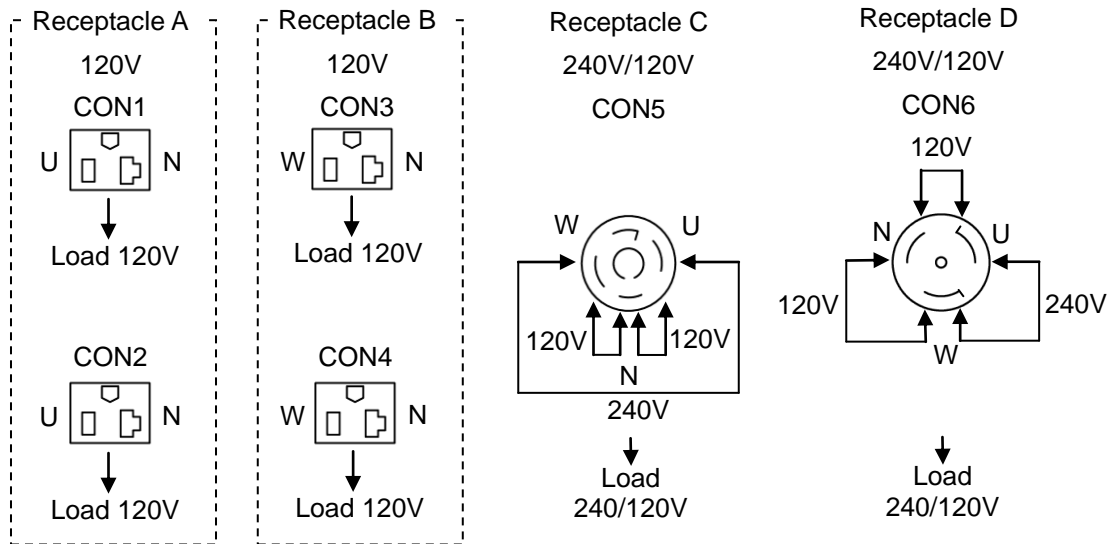

#### ■ Use is possible up to the kVA as shown below.

(Unit: kVA)

	Receptacle A 120V		Receptacle B 120V		Receptacle C 240/120V	Receptacle D 240/120V	Total
	CON1	CON2	CON3	CON4	CON5	CON6	
U-W	—	—	—	—	7.2	12	14
U-N	Total 2.4		—	—	3.6	6	
W-N	—	—	Total 2.4		3.6	6	

## 8. Pre-Operation Inspection

### **⚠ WARNING : INJURY**

- Always turn the starter switch to the STOP position and stop the engine, then close and lock OPERATION PANEL DOOR before checking or maintaining the engine or any equipment.
- Do not open the check door when the starter switch is in the AUTO or START position. It will cause injury by rotating parts such as cooling fans and fan belt.

### **⚠ CAUTION : BURNS**

- Do not touch the engine and surrounding components immediately after stopping the engine as they are still extremely hot.

### **⚠ CAUTION : FIRE**

- Always be sure to wipe up any spilled fuel or oil.

### 8-1. Checking Engine Oil

To check the engine oil, keep the equipment in leveled position, remove the oil level gauge and wipe so that no oil remains, and then re-insert the dipstick fully. Prior to starting the engine, make sure to fill the engine oil through the oil filler until it reaches the MAX line.

#### < Note >

- Wait approximately five minutes or more after stopping the engine or adding oil before checking the oil level again.
- An accurate oil level reading cannot be obtained if the generator is not placed in leveled position.
- Do not overfill with oil to avoid engine damage.

#### (1) Types of Engine Oil

Use only API service-type CF class.

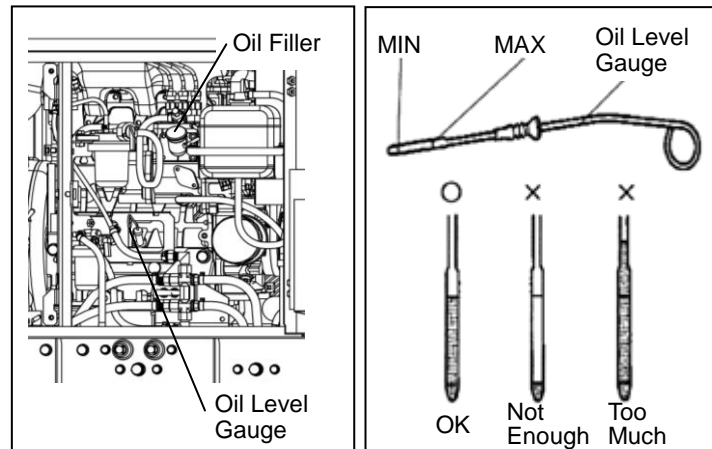

#### (2) Engine Oil Viscosity Grades

Use a diesel engine oil with an appropriate viscosity corresponding to the ambient temperature (refer to the table).

##### ○ Relation of Viscosity/Temperature

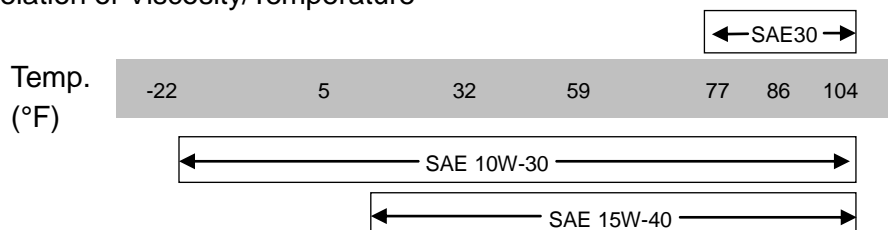

### (3) Engine Oil Replacement Amount

Total Lubrication Oil Amount
1.9 (0.1) gal.

Value in parenthesis is the filter capacity.

## 8-2. Checking Coolant

### **⚠ CAUTION : BURNS**

- Do not open the radiator cap immediately after stopping the engine. Doing so will result in steam gushing out.
- Hot steam gushes out from the coolant sub-tank if the generator overheats. Do not touch the coolant sub-tank.

Check that the sub-tank coolant level is in between FULL and LOW. If the sub-tank coolant is lower than the LOW level, add coolant to the sub-tank and radiator.

#### (1) Filling the Sub-Tank

- 1 Remove the sub-tank cap.
- 2 Fill the sub-tank with coolant until it reaches the FULL line.
- 3 Re-attach the cap.

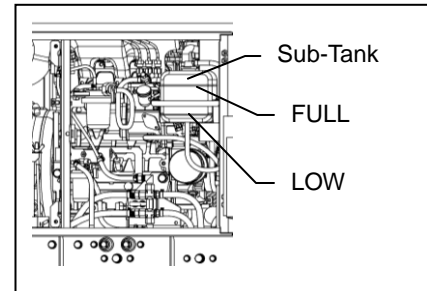

#### (2) Filling the Radiator

- 1 Remove the radiator plate.
- 2 Remove the radiator cap.
- 3 Fill with coolant through the filler neck until the radiator is full.
- 4 Re-attach and tighten the radiator cap.
- 5 Attach the radiator plate.

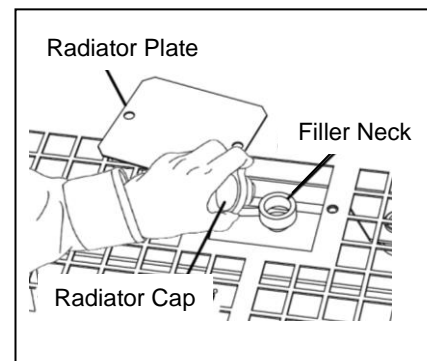

#### < Note >

- Use GM SPEC 6277M or equivalent.
- Use a 50:50 mix of Long Life Coolant (LLC).
- Always use potable water when mixing the coolant.
- Use LLC with the same mixture ratio in the coolant sub-tank.
- Do not increase the LLC mixture ratio unless it is necessary. Doing so could result in overheating or another fault/malfunction.
- If adding LLC, be sure to use the same brand/type that is still in the generator.
- Do not mix different brands/types. Doing so could result in a chemical reaction and the creation of toxic substances.
- Change the LLC every 1,000 hours or 2 years.
- LLC is a toxic substance. Wear rubber gloves and other protective wear when handling.
- If someone mistakenly ingests LLC, induce vomiting immediately and seek medical care.



- If LLC gets on skin or clothing, wash with water immediately.
- LLC is flammable. Store in a location where flame is prohibited and it cannot be accessed by children.
- Engine coolant could leak if the radiator is not completely tightened or there is a gap in the seating face. Always be sure to securely tighten the radiator cap.
- Do not add engine coolant past the FULL level line of the coolant sub-tank.

### (3) Coolant Capacity

Total Coolant Capacity
2.3 (0.3) gal.

Value in parenthesis is the sub-tank capacity.

### 8-3. Checking the Fuel

#### **⚠ CAUTION : FIRE**

- This generator uses diesel fuel. Always be sure to stop the engine and not bring flames close when inspecting fuel or refueling. Wait until the engine has cooled before performing such procedures.
- If fuel spills, always be sure to open the spill containment drain valve and drain off the spilled fuel.  
(Refer to section “**10. Inspection/Maintenance (9) Flushing Liquid in Spill Containment**”.)

Check if there is a sufficient amount of fuel and add fuel if insufficient.

The fuel meter on the control panel will only display the fuel level for the internal fuel tank.

Be sure to close the cap tightly after refueling.

#### < Note >

- Use Diesel fuel, ASTM D975 No.2-D, S15. Engine is designed to operate on Ultra Low Sulfur Diesel Fuel only. Use of any other fuel may result in engine no longer operating in compliance with emissions requirements.
- The fuel supply pump, injectors and other parts of the fuel system and engine can be damaged if any fuel or fuel additives are used other than those specifically recommended by the engine manufacturer.
- Always be sure to use the fuel strainer attached to the fuel inlet.
- Carefully add fuel until the tank is full.
- Always be sure to wipe up any spilled fuel.

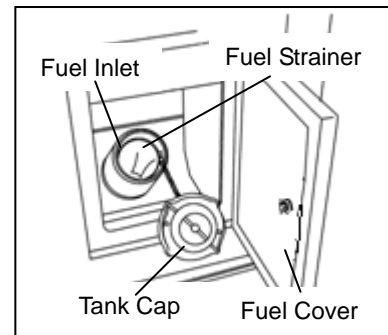

### 8-4. Checking the Spill Containment

#### **⚠ CAUTION : FIRE**

- If fuel or oil leaks, repair the leaking location before operating.

Open the check door and check the inside of the spill containment. Flush out any accumulated liquid. Refer to section “**10. Inspection/Maintenance (9) Flushing Liquid in Spill Containment**” for flushing procedures.

**< Note >**

- The types of liquids that can accumulate in the spill containment include oil, fuel, coolant and battery fluid such that it is not possible to distinguish between rain water and other liquids. Dispose of flushed liquids according to the related laws and regulations.

**8-5. Checking for Fuel, Oil and Coolant Leaks**



- If fuel or oil leaks, repair the leaking location before operating.

Open the check door and check for fuel, oil and coolant leakage from fuel piping connections and similar locations.

**8-6. Checking the Battery**

**California Proposition 65**



Batteries, battery posts, terminals and related accessories contain lead and lead compounds, and other chemicals known to the State of California to cause cancer and birth defects or other reproductive harm. WASH HANDS AFTER HANDLING.



- Wear rubber gloves and other protective wear to protect eyes, skin and clothing from the battery fluid which contains diluted sulfuric acid. If the battery fluid contacts eyes or skin, wash out immediately with a large amount of water. Be sure to receive medical treatment, especially if the fluid contacts the eyes.



- Never use or recharge the battery if the fluid level is below the minimum level.
- Do not create sparks or bring flame near the battery as it generates flammable gas.

1 Check the fluid level, and add distilled water to the upper level until it reaches the upper level.

2 Check the terminals for looseness and tighten properly.

**< Note >**

- It is necessary to recharge the battery when the specific gravity of the battery fluid is 1.23 or less. Request the authorized distributor where the generator was purchased to recharge the battery.

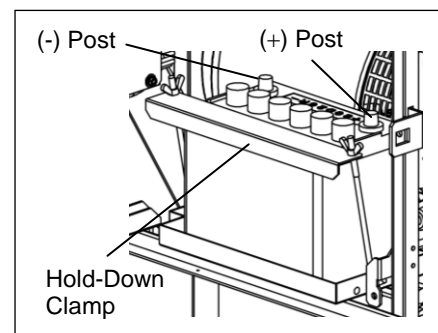
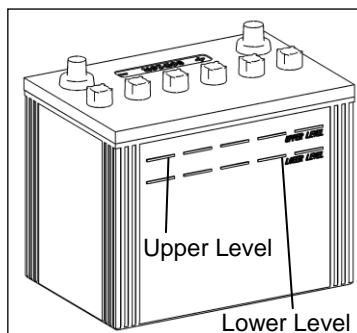

## ■ Replacing the Battery

- 1 Remove the battery negative (-) cable. (Always be sure to remove the negative (-) side first. )
- 2 Remove the battery hold-down clamp.
- 3 Remove the battery positive (+) cable.
- 4 Remove the battery.

\* Install the battery by performing the above procedures in the reverse order.  
(First connect the positive (+) cable of the replaced battery. )

## 9. Operating Procedures

### 9-1. Initial Startup/Pre-Check

#### **WARNING : EXHAUST GAS POISONING**

- Do not operate the generator in poorly ventilated areas such as indoors or tunnels, as the exhaust gas of the engine contains substances that are harmful to human health.
- Do not direct exhaust fumes at bystanders or buildings.

#### **WARNING : INJURY**

- Always be sure to check that the breakers on load side and switches for any equipment using the generator are at OFF before turning the breaker to ON. Also be sure to advise personnel on the load side that power will be turned on before operating the breaker.
- Close all doors and lock them during operation.
- Do not open the check door when the starter switch is in the AUTO or START position. It will cause injury by rotating parts such as cooling fans and fan belt.
- Always turn the starter switch to the STOP position and stop the engine, then close and lock OPERATION PANEL DOOR before checking or maintaining the engine or any equipment.

#### **CAUTION : FIRE**

- Do not carry flammable items (such as fuel, gas and paint) or items that are highly combustible near the generator as the muffler, exhaust gas and other parts become extremely hot.
- Position this generator 3 ft. (1 m) or more from walls or other hindrances, and on a level surface.

#### **CAUTION : INJURY**

- Do not operate the generator if it has been modified or any parts have been removed.
- Position the generator on a level stable surface so that it cannot slide or move in any manner.
- Before starting operation, always be sure to turn off all switches of equipment being used and all breakers to OFF.

### < Note >

- Check that the surrounding area is safe before starting the engine.
- When there are multiple workers who are working together, they must mutually signal each other before starting the engine.
- Do not use in an area with high temperature or humidity, or an area with a large amount of dust.
- Do not open any doors during operation. Operating with door open can negatively affect cooling effect, resulting in an equipment malfunction.
- Use ear protection if the level of noise is high. Failure to do so could result in hearing damage.
- Please be careful about a strong wind and the opening and shutting of the door. If a door is opened suddenly and is closed, a finger might be sandwiched.

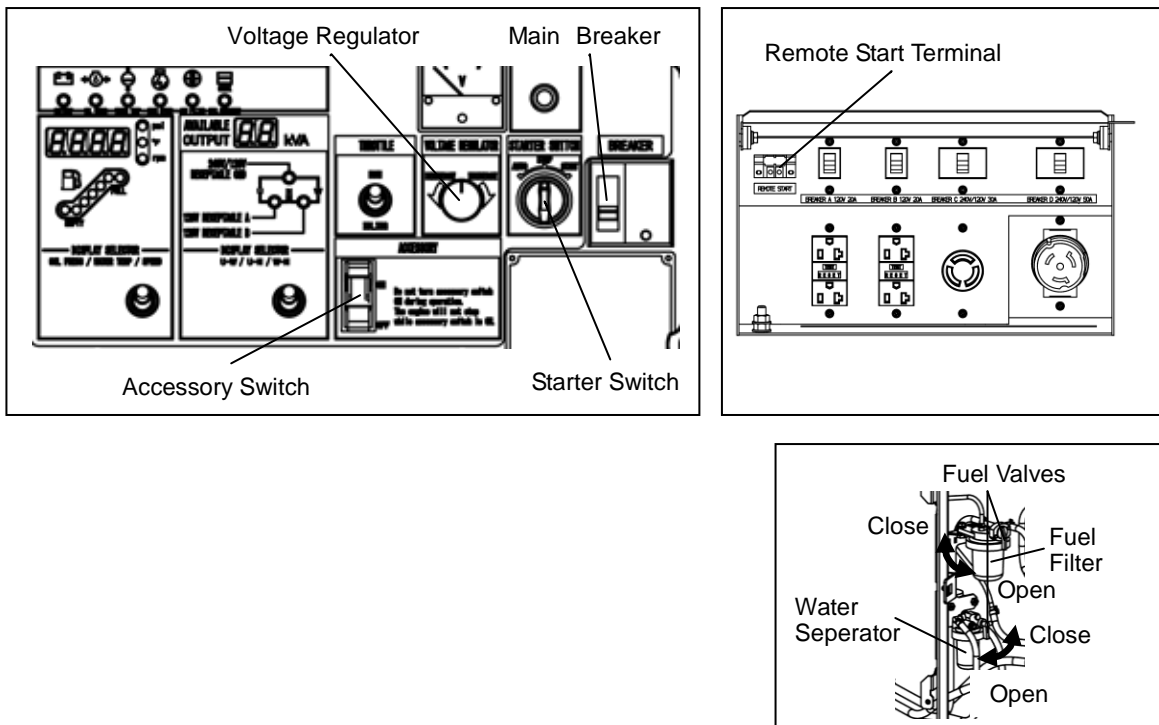

### (1) Manual Start

- 1 Turn off the main breaker on the operation panel of this machine.
- 2 Set the ACCESSORY switch to OFF, and use the safety cap to cover it.
- 3 Open the fuel valves.
- 4 Set the STARTER SWITCH selector to START position.

### < Note >

- The warm-up process starts automatically.
- Please keep in mind that the muffler may emit some smoke when engine is started.
- Never turn accessory switch ON during operation. The engine keeps running while accessory Switch is ON

- 5 Use the VOLTAGE REGULATOR dial to adjust the voltage to the specified value.

60Hz 240V

- 6 Turn on the breaker to activate power supply.

## (2) Auto Start

- 1 Use the VOLTAGE REGULATOR dial to adjust the voltage to the specified value.
- 2 Turn on the main breaker on the operation panel of this machine.
- 3 Set the ACCESSORY switch to OFF position, and use the safety cap to cover it.
- 4 Confirm the fuel valves are open.
- 5 Set the STARTER SWITCH selector to AUTO position.
- 6 The engine starts when the "REMOTE START" terminal closes.

### < Note >

- Please keep in mind that the muffler may emit some smoke when the engine is started.
- Never turn accessory switch ON during operation. The engine keeps running while accessory Switch is ON

## 9-2. Procedures during Operation

### (1) Checks after Startup

- Make sure that all meters and indicators are in normal status. (Refer to section "5. Equipment".)
- Check that there is no abnormal vibration or noise.
- Check that the exhaust gas color is normal. When operation is normal, the exhaust gas should be colorless or slightly bluish.

### < Note >

- If abnormal, stop using this generator and request authorized distributor where the generator was purchased to repair the generator.

### (2) Adjustment during Operation

During load operation, check the voltmeter and finely adjust voltage using the voltage regulator dial.

#### ■ Restarting after stopping due to running out of fuel

The fuel filter includes an automatic air-bleeding device. Restart the engine according to the following procedures even if the engine has stopped due to running out of fuel.

- 1 Turn the main breaker in the operation panel to OFF position.
- 2 Turn the starter switch to STOP position.
- 3 Pour fuel to fuel tank.
- 4 Set the STARTER SWITCH selector to START, and confirm the engine has started properly.
- 5 The engine speed is unstable for approximately one minute until the air has been completely pulled out from the fuel line. The engine speed stabilizes once the air is pulled out.

### < Note >

- If engine has stopped immediately after starting, the machine attempts to restart it automatically.
- If the OVER CRANK indicator illuminates, return the STARTER SWITCH selector to the STOP position first, and then set to START again.

### 9-3. Stopping Operation



#### **CAUTION : BURNS**



- Do not touch the engine and surrounding components immediately after stopping the engine as they are still extremely hot.

#### **(1) Manual Start**

- 1 Turn the switches and breakers on the load side to OFF position.
- 2 Turn off the main breaker on the operation panel of this machine.
- 3 Confirm that the "ACCESSORY" switch is set to OFF position.
- 4 The engine cools down for approximately 3 minutes.
- 5 Turn the starter switch to STOP position.
- 6 After engine stops, turn the fuel levers to CLOSE.

#### **< Note >**

- Never turn accessory switch ON during operation. The engine keeps running while accessory switch is ON.
- If the engine does not stop even if the STARTER SWITCH is set to STOP, close the fuel levers. The engine will stop after a few minutes. If this occurs, stop using the generator and request authorized distributor to repair where this generator was purchased.
- Set the STARTER SWITCH selector to STOP position if the generator will not be used for a prolonged period. If you leave the selector in the AUTO or START position, the standby current may drain the battery.

#### **(2) Auto Start**

- 1 The engine stops when the REMOTE START terminal opens.
- 2 Set the STARTER SWITCH selector to STOP position, and close the fuel levers if the generator may not be used for a prolonged period.

#### **< Note >**

- Never turn accessory switch ON during operation. The engine keeps running while accessory switch is ON.
- Close the fuel levers if the engine does not stop when the REMOTE START terminal opens. The engine will stop after a few minutes. If this occurs, stop using the generator and request authorized distributor to repair where this generator was purchased.
- Set the STARTER SWITCH selector to STOP position if the generator may not be used for a prolonged period. If you leave the selector in the "AUTO" or START position, the standby current may drain the battery.

### 9-4. Protective Functions



#### **WARNING : INJURY**



- Do not open the check door when the starter switch is in the AUTO or START position. It will cause injury by rotating parts such as cooling fans and fan belt.
- Always turn the starter switch to the STOP position and stop the engine, then close and lock OPERATION PANEL DOOR before checking or maintaining the engine or any equipment.

**CAUTION : BURNS**

- Do not touch the engine and surrounding components immediately after stopping the engine as they are still hot.
- Hot steam gushes out from the coolant sub-tank if the generator overheats. Do not touch the coolant sub-tank.

This generator is equipped with functions to automatically stop operation when there is a fault/malfunction during operation, and one to warn the operator of the fault location by use of indicator lamps. Check the fault location when the engine is automatically stopped or an indicator lamp illuminates to stop the engine.

**Protection Feature List**

No.	Action Abnormality		Breaker Trip	Engine Automatic Shutdown	Warning Lamp Flash	Cause
1	Monitor Lamp	High Water Temperature	-	○	○	Activates due to high water temperature in the engine Default 239°F (115 °C)
2		Low Oil Pressure	-	○	○	Activate due to low oil pressure in the engine Default 7 psi (0.49 × 100 kPa)
3		Insufficient Battery Charge	-	○	○	Activates in battery charge Impossible
4		Engine Overspeed	-	○	○	Engine speed is too fast (2070 rpm or more)
5	Monitor Lamp	Air Filter Clogging Up	-	-	○	The element is clogged making it necessary to clean or replace the element.
6		Spill Containment Fluid Level	-	-	○	Spill containment accumulated fluid has exceeded the specified level making it necessary to flush the fluid.
7	Spill Containment Fluid Overflow		-	○	○	Spill containment accumulated fluid has exceeded the specified level making it near the fill.
8	Overload		○	-	-	Activates in overload
9	Over Crank		-	-	○	Engine startup control failure
10	Rotation signal loss		-	○	Flashing	When rotation signal disappears

\* ○ indicates the automatic activation.

## 9-5. Connecting with External Fuel Tank

### **CAUTION : FIRE**

- Always make sure that the engine is stopped when working on piping.
- Always be sure to wipe up any spilled fuel.
- After working on the piping, check that there is no fuel leakage.

1 Turn the 3way fuel valve lever to the “A” side.  
(Position for using the internal tank.)

2 Remove the plugs(R1/2”) from both the external fuel inlet and the external fuel return.

3 Connect the hoses from an external fuel tank, as shown below.

4 Turn the 3way fuel valve lever to the “B” side.  
(Position for using the external tank.)

5 Bleed air from the external tank connecting hose. Fuel can be supplied from the external tank after completing the above procedures.

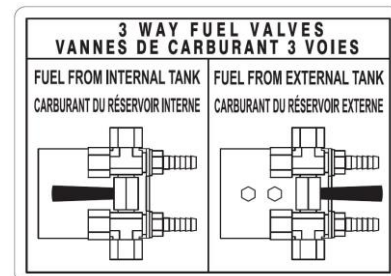
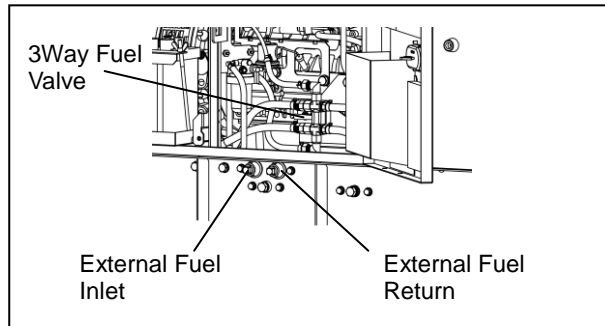

**Position A    Position B**

### < Note >.

- If using a hose for the piping, use oil-resistant hose with an internal diameter of 0.31 to 0.35 in (8 to 9 mm).
- Set the fuel level of the external fuel tank from 0 to 10 ft. (3 m) from the underside of this generator. The fuel level of the external fuel tank being lower than this generator will result in poor engine operation or stoppage.
- Turn the 3way fuel valve lever to the “A” side in order to prevent fuel from flowing out from the external tank fuel inlet/return.
- Turn the lever completely as far as possible. If the lever is not completely pressed to either side, it might not be possible to supply fuel causing the engine to stop.
- Set the supply side so that it is 0.6 to 0.8 in. (15 to 20 mm) above the underside of the tank in order to prevent foreign material or water from being suctioned from inside the external fuel tank.
- Set the external fuel tank return side at the same height as the supply side in order to prevent poor engine operation due to air mixed in with the fuel.
- Refer to section “9-2 Procedures during Operation” for air bleeding.
- Some air may remain in hoses or pipes immediately after connecting the external fuel tank resulting in unstable engine speed and engine stoppage.
- Do not leave the generator unattended for unmanned operation until you have confirmed that the engine speed is stable.

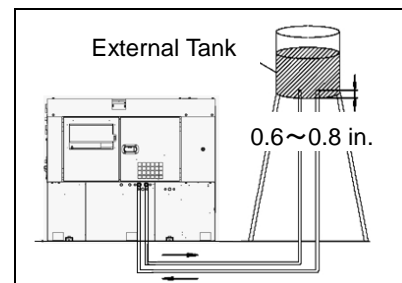



## 10. Inspection/Maintenance

### California Proposition 65

#### **WARNING**

Batteries, battery posts, terminals and related accessories contain lead and lead compounds, and other chemicals known to the State of California to cause cancer and birth defects or other reproductive harm. WASH HANDS AFTER HANDLING.

#### **WARNING : ELECTRIC SHOCK/INJURY**

- Do not touch receptacles or internal electric parts while the generator is operating.
- Do not open the check door when the starter switch is in the AUTO or START position. It will cause injury by rotating parts such as cooling fans and fan belt.
- Always turn the starter switch to the STOP position and stop the engine, then close and lock OPERATION PANEL DOOR before checking or maintaining the engine or any equipment.
- Do not lift up using tie downs. Use of such could result in the generator falling.
- No persons should ever be under a lifted generator.

#### **CAUTION : FIRE**

- Always be sure to wipe up any spilled fuel or oil.

#### **CAUTION : BURNS**

- Do not touch the engine and surrounding components immediately after stopping the engine as they are still extremely hot.
- Do not open the radiator cap immediately after stopping the engine. Doing so will result in steam gushing out.
- Hot steam gushes out from the coolant sub-tank if the generator overheats. Do not touch the coolant sub-tank.

#### **CAUTION : INJURY**

- Personnel performing suspension work must wear protective gear such as helmets, safety shoes and gloves.
- Always be sure to use lifting hooks when suspending the generator, and raise it slowly at a completely vertical angle.

Perform periodic inspection and maintenance according to the following table in order to constantly maintain this generator in good working condition. Use the hour meter as a reference for the operating time.

#### < Note >

- All procedures except for pre-operation inspection should be performed by specialized technicians.
- Request authorized distributor where the generator was purchased to perform the procedures in the table with a “●”.
- Always be sure to use genuine parts or those indicated specifically for replacement parts.
- Use a container to catch fluid bled from this generator that is large enough to prevent the fluid from spilling on the ground.

Dispose of oil, fuel, coolant (LLC), filter, battery and other hazardous materials according to laws and regulations concerning industrial waste.

Contact authorized distributor where the generator was purchased if you have any inquiries regarding proper disposal.

- When check doors are open during maintenance, take measures so that unrelated personnel cannot accidentally come close to the generator. Close all doors and covers if you are going to be away from this generator.
- Please be careful about a strong wind and the opening and shutting of the door at the sloping place enough. When door is opened or closed suddenly, a finger might be sandwiched.

	Description	Daily	Every 100 hrs	Every 200 hrs	Every 400 hrs	Every 450 hrs	Every 500 hrs	Every 800 hrs	Every 1000 hrs	Every 1500 hrs	
Engine	Each parts (Clean/Tightening)	○									
	Engine oil (Check/Add)	○									
	Engine oil (Replace)			○ 1 <sup>st</sup> time at 50 hrs							
	Oil filter (Replace)			○ 1 <sup>st</sup> time at 50 hrs							
	Coolant (Check/Add)	○									
	Coolant (Replace/Radiator Flush)								○ or 2years		
	Exhaust color (Check)	○									
	Water separator (Drain excess water and sediments)		○ 1 <sup>st</sup> time at 50 hrs								
	Fuel filter (Replace)						○				
	Fuel tank (Drain water)			○							
	Water separator and Gauze filter (Clean)						○				
	Fuel tank (Clean)						●				
	Check for leaks (Fuel/Oil/Coolant)	○									
	Fuel/Coolant/Oil Hoses and Anti-Vibration Rubber (Replace)									● or 2years	
	Air filter element (Clean/Replace)		○ 1 <sup>st</sup> time at 50 hrs (Clean)					○ once in 6times cleaning or 1year (Replace)			
	Battery fluid level (Check/Add)	○									
	Battery gravity (Check)	○									
	Fan belt tension (Check)		○ 1 <sup>st</sup> time at 50 hrs								
	Fan belt (Replace)							● or 2years			
	Radiator and fins (Clean)							●			

	Description	Daily	Every 100 hrs	Every 200 hrs	Every 400 hrs	Every 450 hrs	Every 500 hrs	Every 800 hrs	Every 1000 hrs	Every 1500 hrs
Engine	Valve clearance (Check/Adjust)							●		
	Fuel injector (Check)									●
	Elimination of carbon in the exhaust pipe line and muffler			○						
Generator	Indicators, Gauges (Check)	○								
	Alarms (Check)									
	Insulation test			○						
Others	Spill containment fluid (Check/Drain)	○								
	Spill containment (Check/Clean)	○					● (Clean)			

### (1) Engine Oil Replacement

First Time	50 hours
Thereafter	Every 200 hours

- 1 Set a container to catch spilled engine oil.
- 2 Remove the oil filler cap.
- 3 After removing the oil drain plug and packing (a rubber seal is attached), open the oil drain valve and drain the engine oil.
- 4 After the oil has been drained, close the oil drain valve and reinsert the oil drain plug with new packing (a rubber seal is attached).
- 5 Add oil through the oil filler until it is at the maximum level while checking the oil level using the oil level gauge.
- 6 Attach the oil filler cap.

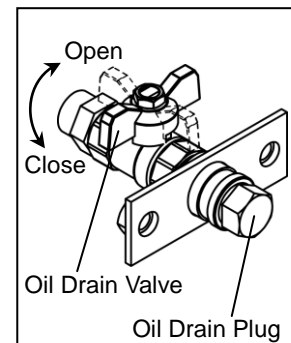
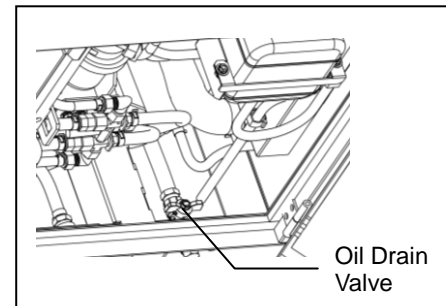
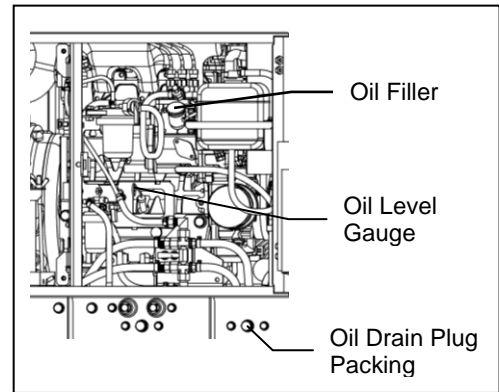

#### < Note >

- Refer to section “8-1. Checking Engine Oil” for engine oil replacement amounts and types.
- Replace the packing of the oil drain plug with new packing each time the oil is replaced.
- Packing part no.: V106-000190
- After reinserting the oil drain plug and shortly after starting the engine, be sure to always check that there is no oil leakage.

## (2) Replacing the Oil Filter

First Time	50 hours
Thereafter	Every 200 hours

- 1 Drain the engine oil. (Refer to section “(1) Engine Oil Replacement”.)
- 2 Remove the oil filter using a filter wrench.
- 3 Spread a thin layer of oil on a new oil filter gasket.
- 4 Thread the oil filter by hand, and turn by hand (do not use a filter wrench) from when the gasket contacts the seal surface until it is securely tightened.
- 5 Add engine oil to the generator.
- 6 Shortly after starting the engine, always be sure to check that there is no oil leaking from the seal surface.

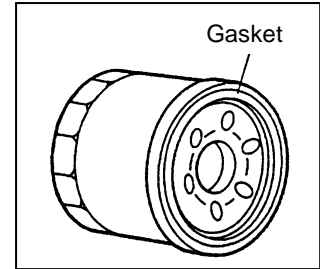

### < Note >

- Request the authorized distributor where the generator was purchased to perform this procedure if you do not have a filter wrench.
- Oil filter part no.: 16414-32434 (Kubota part no.)

## (3) Air Filter Element Cleaning/Replacement

First Time (clean)	50 hours
Thereafter (clean)	Every 100 hours
Replace	once in 6 times cleaning or Every 1 year

- 1 Remove the air cleaner clips and cleaner cap.
- 2 Remove the element.
- 3 Clean or replace the element. Replace by performing the above procedures in reverse order.

### < Note >

- Always be sure to turn the cleaner cap in the direction indicated by the arrow.
- Replace the elements earlier if using in an excessively dusty location.
- Do not add oil as this generator uses a dry element.
- Clear foreign material by pinching the vacuator valve once a week in normal operating conditions or daily if operating in a location that is excessively dirty or dusty. Wipe away any dirt or moisture that has adhered to the parts.
- Never touch the elements for any reason except cleaning.
- Element part no.: TA040-93231 (Kubota part no.)

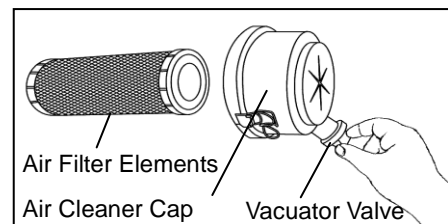
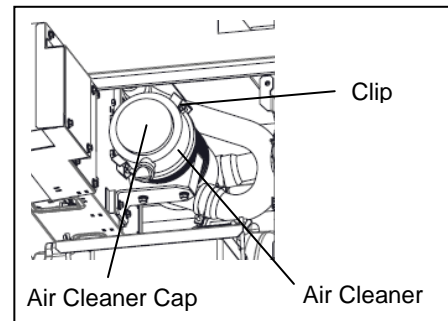

■ Cleaning the air filter element

If dry dust is adhering:

Blow compressed air from inside the element.

If carbon or oil is adhering:

Replace with new parts.

**(4) Draining Water from the Water Separator**

First Time	50 hours
Clean	Every 100 hours

Drain water when the float (red) inside the cup floats to the water draining position.

- 1 Set a container to catch spilled water.
- 2 Close the fuel valve.
- 3 Unscrew the retainer ring counterclockwise, and remove the cup and the gauze filter.
- 4 If foreign material is adhering to the gauze filter in the cup, remove the cup and gauze filter, and clean by blowing compressed air from the inside of the gauze filter.
- 5 Reassemble the gauze filter and cup to their original location.

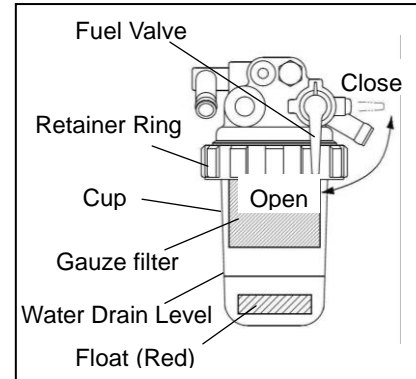

**< Note >**

- When attaching the cup, check that there is no foreign material adhering to the O-ring.
- After attaching, open the fuel valve, and be sure to always start the engine and check that there is no fuel leakage.
- If water is accumulate in the cup, draining water from the fuel tank.

**(5) Draining Water from the Fuel Filter/Replacement**

Replace	Every 450 hours
---------	-----------------

- 1 Set a container to catch spilled fuel.
- 2 Close the fuel valve.
- 3 Unscrew the retainer ring counterclockwise, and remove the cup and the fuel filter.
- 4 If foreign material is adhering to the fuel filter in the cup, remove the cup and fuel filter, and clean by blowing compressed air from the inside of the fuel filter.
- 5 Reassemble the fuel filter and cup to their original location.

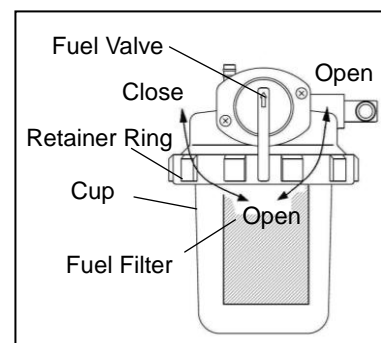

### < Note >

- When attaching the cup, check that there is no foreign material adhering to the O-ring.
- After attaching, open the fuel valve, and be sure to always start the engine and check that there is no fuel leakage.
- Always be sure to wipe up any spilled fuel.
- If water is accumulate in the cup, draining water from the fuel tank and the water separator.
- Element part no.: 15521-43161 (Kubota part no.)

### (6) Draining Water from the Fuel Tank

Drain Water	Every 200 hours
-------------	-----------------

- 1 Set a container to catch spilled water.
- 2 Remove the fuel drain plug and packing (with rubber seal).  
After the water has been drained, reinsert the fuel drain plug with new packing (with rubber seal).
- 3

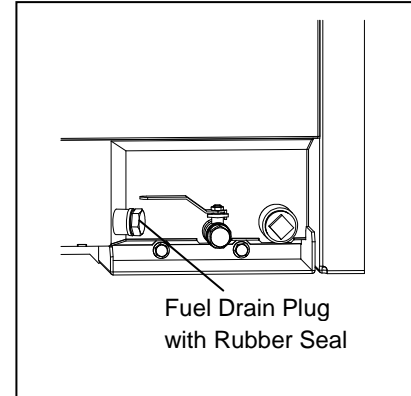

### < Note >

- Replace the packing of the fuel drain plug with new packing each time the water is drained.
- Packing part no.: V106-000110
- After reinserting the fuel drain plug, be sure to always check that there is no fuel leakage.

### (7) Coolant Replacement

Replace	Every 1000 hours or 2 years
---------	-----------------------------

- 1 Set a container to catch spilled coolant.
- 2 Remove the radiator plate.
- 3 Remove the radiator cap.
- 4 Remove the coolant drain plug and packing.
- 5 After the coolant has been drained, reinsert the coolant drain plug with new packing.
- 6 Remove the sub-tank and flush the coolant from the sub-tank.
- 7 Reattach the sub-tank to its original position and fill with coolant until it reaches the FULL level.
- 8 Fill the radiator with coolant until it reaches the filler neck.
- 9 Re-attach and tighten the radiator cap.
- 10 Attach the radiator plate.

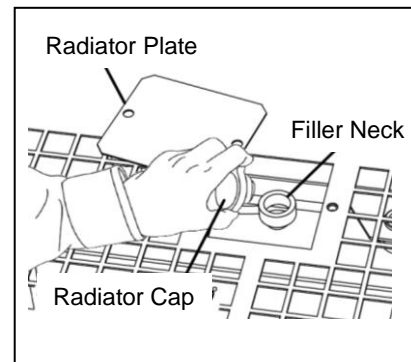

### < Note >

- Refer to section "8-2. Checking Coolant" for coolant information.
- Replace the packing of the coolant drain plug with new packing each time the coolant is changed.
- Packing part no.: 6C090-58961 (Kubota part no.)
- After reinserting the coolant drain plug and shortly after starting the engine, be sure to always check that there is no coolant leakage.

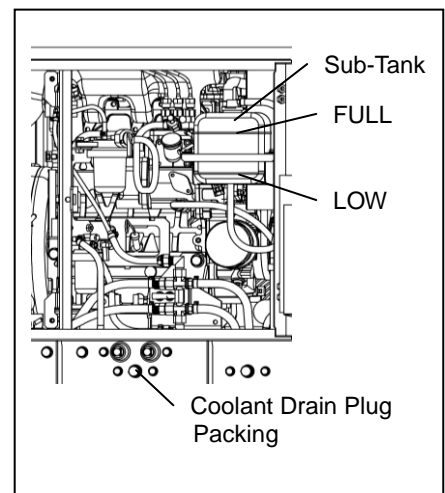

## (8) Checking the Fan Belt

First Time	50 hours
Thereafter	Every 100 hours

### ① Fan Belt Tension

Press your finger against the middle of the fan belt. (approx. 98N) If the slack is 0.27 to 0.35 inch, the tension is normal.

### ② Fan Belt Condition

Check the fan belt for damage and replace if any damage or other fault is found.

### ③ Fan Belt Adjustment

- 1 Remove the fan guard.
- 2 Loosen the bolts of the alternator.
- 3 Pull the alternator out and adjust the fan belt tension.
- 4 Securely tighten the bolts of the alternator.
- 5 Check that the fan belt tension is correct.
- 6 Attach the fan guard.

#### < Note >

- Use of a loose or damaged fan belt could result in overheating or insufficient charging.
- Do not operate the generator if fan guard has been removed.
- Request the authorized distributor where the generator was purchased to replace the fan belt.

## (9) Flushing Liquid in Spill Containment

Check	Daily
-------	-------

- 1 Set a container to collect liquid from the flushing port of the drain valve on the front of this generator.
- 2 Remove the drain valve plug (R 1/2") and open the valve lever.

#### < Note >

- When removing or attaching the plug, hold the drain valve fixed using a spanner or similar tool and turn the plug.
  - If oil or other liquid is mixed in with the flushed liquid, this indicates that there is an oil leak. In such case, check for the leak location.
  - The types of liquids that can accumulate in the spill containment include oil, fuel, coolant water and battery fluid such that it is not possible to distinguish between rain water and other liquids. Dispose of flushed liquids according to the related laws and regulations.
- 3 Close the valve lever after the liquid has been flushed, and apply sealant coating to the plug or wrap it in seal tape.

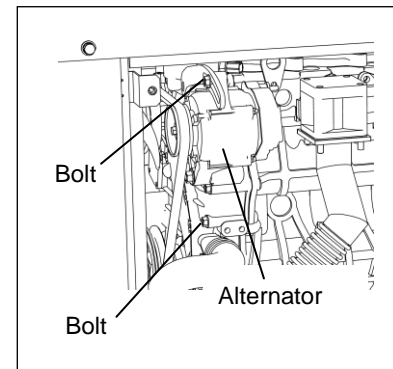
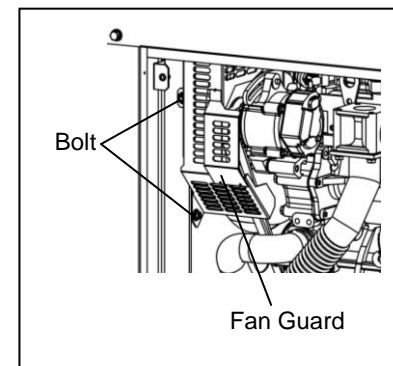
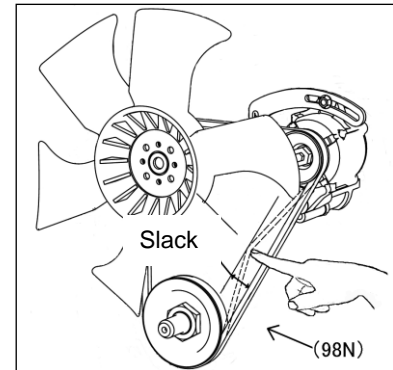

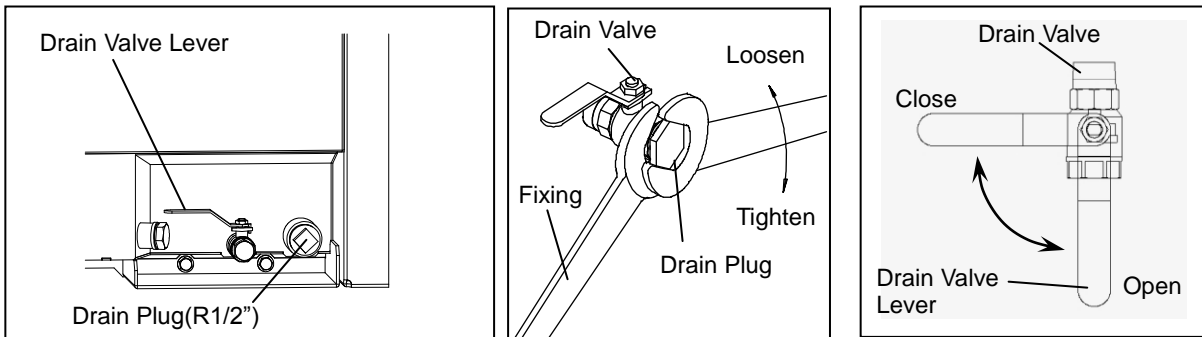

## (10) Spill Containment Cleaning/Inspection



### WARNING : INJURY



- Do not lift up the unit using tie downs. Use of such could result in the generator falling.
- No persons should ever be under a lifted generator.



### CAUTION : INJURY

- Always be sure to use lifting hooks when lifting up the generator, and raise it slowly at a completely vertical angle.
- Personnel performing lifting work must wear protective gears such as helmets, safety shoes and gloves.
- Do not move the generator during operation.

Clean

Every 500 hours

Separate the spill containment from this generator to clean and inspect the spill containment.

#### ■ Spill Containment Separate/ Reassemble

- 1 Turn the 3way fuel valve lever to the "B" side.
- 2 Remove the wiring connector.
- 3 Remove the fuel hoses (supply and return sides).
- 4 Remove the four spill containment fixing bolts (M12, 4 pieces).

#### < Note >

- When removing the fuel hoses, hold the union joint fixed using a spanner or similar tool.
- Prepare a container to receive the fuel remaining in the fuel piping that will flow out of the removed fuel piping.

- 5 Lift the generator, separate the spill containment and set the generator on a flat surface.
- 6 After cleaning and inspecting the inside of the spill containment, reassemble the spill container with this generator by performing the above procedures in the reverse order.
- 7 Reassemble the fuel piping and wiring connector to their original positions.
- 8 Turn the 3way fuel valve lever to the "A" side.

#### < Note >

- After reassembling, bleed air from the fuel system.  
(Refer to section "9-2. Procedures during Operation".)
- After reassembling, check that there is no fuel leakage.

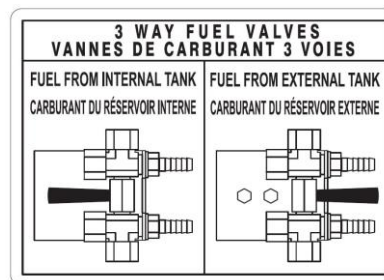

Position A Position B



## ■ Spill Containment Cleaning/Inspection

- 1 Use a high-pressure cleaner or similar equipment to clean the inside of the spill containment.
- 2 Remove the drain plug (R1") to drain the cleaning water.
- 3 Check that there no rust has developed inside of the spill containment. If rust has developed, remove the rust and clean again.
- 4 Tentatively, apply sealant coating to the plug (R1") or wrap it in seal tape and reinsert it.
- 5 Allow water to accumulate and check that the spill containment has no internal leakage.
- 6 Remove the drain plug (R1") to drain the water.
- 7 After the procedures have been completed, apply sealant coating to the plug (R1") or wrap it by seal tape and reinsert it.

### < Note >

- If the fluid drained when cleaning the spill containment contains oil or grease, dispose of it according to the related laws and regulations.
- If the spill containment has a leak, contact the authorized distributor where the generator was purchased.

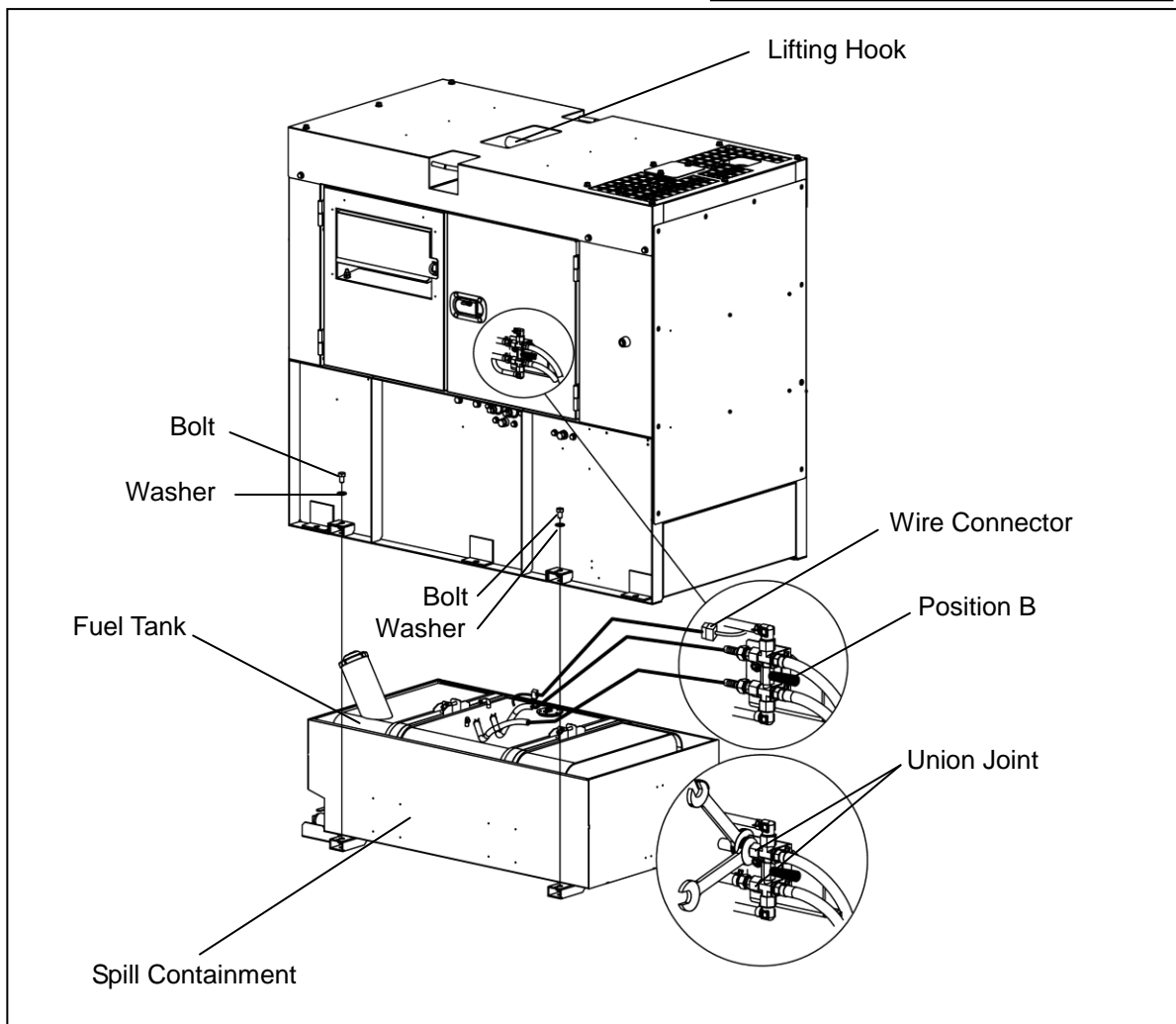
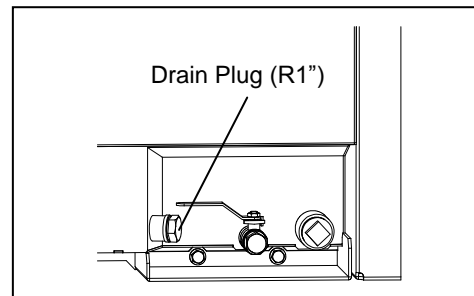

## (11) Elimination of excessive carbon in the exhaust system by extensive light load

### **WARNING : EXHAUST GAS POISONING**

- Do not operate the generator in poorly ventilated areas such as indoors or tunnels, as the exhaust gas of the engine contains substances that are harmful to human health.
- Do not direct exhaust fumes at bystanders or buildings.

### **WARNING : INJURY**

- Always be sure to check that the breakers on load side and switches for any equipment using the generator are at OFF before turning the breaker to ON. Also be sure to advise personnel on the load side that power will be turned on before operating the breaker.
- Close all doors and lock them during operation.

### **CAUTION : FIRE**

- Do not carry flammable items (such as fuel, gas and paint) or items that are highly combustible near the generator as the muffler, exhaust gas and other parts become extremely hot.
- Position this generator 3 ft. (1 m) or more from walls or other hindrances, and on a level surface.

### **CAUTION : INJURY**

- Do not operate the generator if it has been modified or any parts have been removed.
- Position the generator on a level stable surface so that it cannot slide or move in any manner.
- Before starting operation, always be sure to turn off all switches of equipment being used and all breakers to OFF.

Clean

Every 200 hours

Accumulation of carbon (soot, unburned fuel) in the exhaust system could cause engine output loss and/or engine fault. To eliminate soot and unburned fuel, run the unit at more than 70% of the rated output for about half an hour, until the exhaust gas become mostly colorless. The carbon will accumulate when the unit runs at less than 30% of rated output.

#### < Note >

- When the unit runs at rated power suddenly, accumulation of carbon in the exhaust system might cause back fire incident. Operate the generator starting from 50% of the rated output and then increase load gradually after confirming exhaust gas become colorless. Do not carry flammable items that are highly combustible near the generator.

## 11. Long-Term Storage

### **WARNING : INJURY**

- Always turn the starter switch to the STOP position and stop the engine, then close and lock OPERATION PANEL DOOR before checking or maintaining the engine or any equipment.

**⚠ CAUTION : FIRE** 

- Always be sure to wipe up any spilled fuel or oil.
- Allow the generator to cool before covering with the protective cover.

**⚠ CAUTION : BURNS** 

- Do not touch the engine and surrounding components immediately after stopping the engine as they are still extremely hot.

### (1) Storage Procedures

Perform the following maintenance procedures before storing this generator if it is not going to be used for two months or more.

- 1 Remove the battery. (Refer to section “8-6. Checking the Battery ”.)
- 2 Replace the engine oil.  
(Refer to section “10. Inspection/Maintenance (1) Engine Oil Replacement”.)
- 3 Drain the fuel from the fuel tank and filter.  
(Refer to section “10. Inspection/Maintenance (5) Draining Water from the Fuel Filter /Replacement”.)  
(Refer to section “10. Inspection/Maintenance (6) Draining Water from the Fuel Tank”.)
- 4 Clean up and inspect inside of the spill containment.  
(Refer to section “10. Inspection/Maintenance (10) Spill Containment Cleaning/Inspection”.)
- 5 Store in a secure location.
- 6 Clean up all generator components, and store in a dry and dust-free location. Also cover when storing so that rain cannot enter through the suction or exhaust ports.

#### < Note >

- Adjust the fluid of the removed battery to the appropriate level and recharge approximately every month.

### (2) Double-Stacking Storage Procedures

**⚠ WARNING : INJURY** 

Always be sure to observe the following items when double stacking this generator in a warehouse or similar location.

- Check that the hood of this generator is not dented, and that bolts are not loose or missing.
- Set in a location with a flat hard floor capable of withstanding the double-stacking weight.
- Always be sure to use lifting hooks when lifting this generator.
- Insert wood ties of the same size and that are wider than this generator between each generator, and set another generator on top of the ties.
- Never stack more than two levels, and do not set a generator on top that is larger in weight/size than that on the bottom.
- Do not operate the generator when it is double stacked.

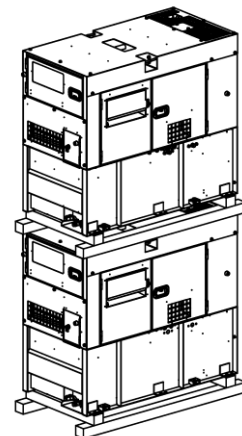

## 12. Troubleshooting

**⚠ WARNING : ELECTRIC SHOCK/INJURY** 

- Do not touch output terminals or internal electric parts while the generator is operating.
- Do not open the check door when the starter switch is in the AUTO or START position. It will cause injury by rotating parts such as cooling fans and fan belt.
- Always turn the starter switch to the STOP position and stop the engine, then close and lock OPERATION PANEL DOOR before checking or maintaining the engine or any equipment.

**⚠ CAUTION : FIRE** 

- Never allow flame to come close to the generator.

**⚠ CAUTION : BURNS** 

- Do not touch the engine and muffler after stopping the engine as they are still extremely hot.

Inspect this generator when operation is poor to determine the fault/malfunction.

Request the authorized distributor where the generator was purchased to perform maintenance if you cannot find any faults/malfunctions during inspection.

	Problem	Suspected cause	Action
Engine does not start	Starter motor does not drive or speed is low	<ol style="list-style-type: none"> <li>1. Battery output is weak</li> <li>2. Battery is deteriorated</li> <li>3. Battery terminal is OFF or loosen</li> <li>4. Battery terminal is corroded</li> <li>5. Starter switch or relay is defective</li> <li>6. Starter motor is defective</li> <li>7. ECU (Engine Controller) is defective</li> </ol>	<ol style="list-style-type: none"> <li>1. Check battery fluid or charge</li> <li>2. Replace Battery</li> <li>3. Fix/Tighten terminal</li> <li>4. Clean terminal</li> <li>5. Contact distributor or dealer for repair</li> <li>6. Contact distributor or dealer for repair</li> <li>7. Contact distributor or dealer for repair</li> </ol>
	Starter motor drives but engine does not start	<ol style="list-style-type: none"> <li>1. Fuel is insufficient</li> <li>2. Fuel filter is clogged</li> <li>3. Gauze filter is clogged</li> <li>4. Water is interfused in fuel line</li> <li>5. Air is interfused in fuel line</li> <li>6. Mistake of connecting with external tank</li> <li>7. Mistake of turning 3way fuel valve lever</li> <li>8. Fuel pump defective</li> <li>9. Solenoid fault</li> </ol>	<ol style="list-style-type: none"> <li>1. Add fuel</li> <li>2. Clean/Replace fuel filter</li> <li>3. Clean/Replace gauze filter</li> <li>4. Drain water in water separator, fuel filter or fuel tank</li> <li>5. Extract the air</li> <li>6. Check fuel piping</li> <li>7. Check 3way fuel valve</li> <li>8-1. Check/Replace fuse</li> <li>8-2. Check/Replace fuel pump</li> <li>9-1. Check/Replace fuse</li> <li>9-2. Ask our distributor to repair</li> </ol>
	<Ambient temperature falls down below zero>	<ol style="list-style-type: none"> <li>1. Fuel is frozen</li> <li>2. Water in fuel line is frozen</li> <li>3. Pre-heater is defective</li> </ol>	<ol style="list-style-type: none"> <li>1. Use winterized fuel</li> <li>2. Drain water in fuel line</li> <li>3. Ask distributor or dealer to repair</li> </ol>

Problem	Suspected cause	Action
Engine starts but stalls immediately	<ol style="list-style-type: none"> <li>1. Fuel filter is clogged</li> <li>2. Gauze filter is clogged</li> <li>3. Water is interfused in fuel line</li> <li>4. Air is interfused in fuel line</li> <li>5. Mistake of connecting with external tank</li> <li>6. Air filter element is clogged</li> <li>7. Lubricant oil is insufficient</li> <li>8. Emergency operation/Fault detection</li> </ol>	<ol style="list-style-type: none"> <li>1. Clean/Replace fuel filter</li> <li>2. Clean/Replace gauze filter</li> <li>3. Drain water in water separator, fuel filter or fuel tank</li> <li>4. Extract the air</li> <li>5. Check fuel piping</li> <li>6. Check/Replace air filter element</li> <li>7. Add lubricant oil</li> <li>8. Ask our distributor to repair</li> </ol>
Engine does not stop	<ol style="list-style-type: none"> <li>1. Solenoid fault</li> <li>2. Accessory switch is turned on</li> </ol>	<ol style="list-style-type: none"> <li>1. Turn the fuel levers to close to stop the engine and ask distributor or dealer to repair</li> <li>2. Turn off the accessory switch</li> </ol>
Engine oil pressure is low	<ol style="list-style-type: none"> <li>1. Lubricant oil is insufficient</li> <li>2. Oil filter is clogged</li> <li>3. Oil Pressure switch is defective</li> <li>4. Oil pressure meter is defective</li> <li>5. Wrong oil is used</li> </ol>	<ol style="list-style-type: none"> <li>1. Add lubricant oil</li> <li>2. Replace oil filter ask our distributor to repair</li> <li>3. Ask our distributor to repair</li> <li>4. Ask our distributor to repair</li> <li>5. Change to proper kind and viscosity oil</li> </ol>
Overheated	<ol style="list-style-type: none"> <li>1. Engine thermostat is defective</li> <li>2. Water temp sensor is defective</li> <li>3. Water temp meter is defective</li> <li>4. Fan belt tension is weak</li> <li>5. Coolant is insufficient</li> <li>6. Radiator core is clogged</li> </ol>	<ol style="list-style-type: none"> <li>1. Ask our distributor to repair</li> <li>2. Ask our distributor to repair</li> <li>3. Ask our distributor to repair</li> <li>4. Check/Adjust fan belt</li> <li>5. Check/Add coolant</li> <li>6. Clean radiator core</li> </ol>
Black smoke comes out from Muffler	<ol style="list-style-type: none"> <li>1. Air filter element is clogged</li> <li>2. Fuel injection nozzle is defective</li> <li>3. Improper fuel is used</li> </ol>	<ol style="list-style-type: none"> <li>1. Check/Change air filter element</li> <li>2. Ask our distributor to repair</li> <li>3. Change to clean fuel</li> </ol>
White smoke comes out from Muffler	<ol style="list-style-type: none"> <li>1. Too much or too little oil to cylinder</li> <li>2. Water is interfused in fuel line</li> <li>3. Fuel injection nozzle is defective</li> <li>4. Coolant temperature is too low</li> <li>5. Engine thermostat is defective</li> </ol>	<ol style="list-style-type: none"> <li>1. Ask our distributor to repair</li> <li>2. Drain water in water separator, fuel filter or fuel tank</li> <li>3. Ask our distributor to repair</li> <li>4. Warm-up driving is needed</li> <li>5. Ask our distributor to repair</li> </ol>
Pointer (hand) does not move in voltage meter	<ol style="list-style-type: none"> <li>1. Voltage meter is defective</li> <li>2. AVR is defective</li> <li>3. Disconnected circuit</li> <li>4. Initial exciter is defective</li> <li>5. Alternator is defective</li> <li>6. AVR protective device operation</li> </ol>	<ol style="list-style-type: none"> <li>1. Ask our distributor to repair</li> <li>2. Ask our distributor to repair</li> <li>3. Ask our distributor to repair</li> <li>4. Ask our distributor to repair</li> <li>5. Ask our distributor to repair</li> <li>6. Replace AVR fuse</li> </ol>
Pointer (hand) does not goes up to the rated voltage	<ol style="list-style-type: none"> <li>1. Voltage meter is defective</li> <li>2. AVR is defective</li> <li>3. Voltage regulator dial is defective</li> </ol>	<ol style="list-style-type: none"> <li>1. Ask our distributor to repair</li> <li>2. Ask our distributor to repair</li> <li>3. Ask our distributor to repair</li> </ol>
Pointer exceeds the rated voltage	<ol style="list-style-type: none"> <li>1. Voltage meter is defective</li> <li>2. AVR is defective</li> <li>3. Improper load cable connection</li> </ol>	<ol style="list-style-type: none"> <li>1. Ask our distributor to repair</li> <li>2. Ask our distributor to repair</li> <li>3. Correctly set the connection location to the receptacle.</li> </ol>

Problem	Suspected cause	Action
The voltage drops drastically when connecting to load	<ol style="list-style-type: none"> <li>1. AVR is defective</li> <li>2. The current of the used equipment exceeds the rated current.</li> <li>3. Over load</li> <li>4. AVR protective device operation</li> </ol>	<ol style="list-style-type: none"> <li>1. Ask our distributor to repair</li> <li>2. Change to a device with an available capacity.</li> <li>3. Decrease the loads to meet the rated output</li> <li>4. Replace AVR fuse</li> </ol>
Cannot turn the breaker to ON	<ol style="list-style-type: none"> <li>1. The Main breaker positions at between ON and OFF</li> <li>2. Short circuit on the load</li> </ol>	<ol style="list-style-type: none"> <li>1. Once turning the lever to OFF, turn it to ON</li> <li>2. Check the load circuit</li> </ol>

# 13. Generator Circuit Diagram

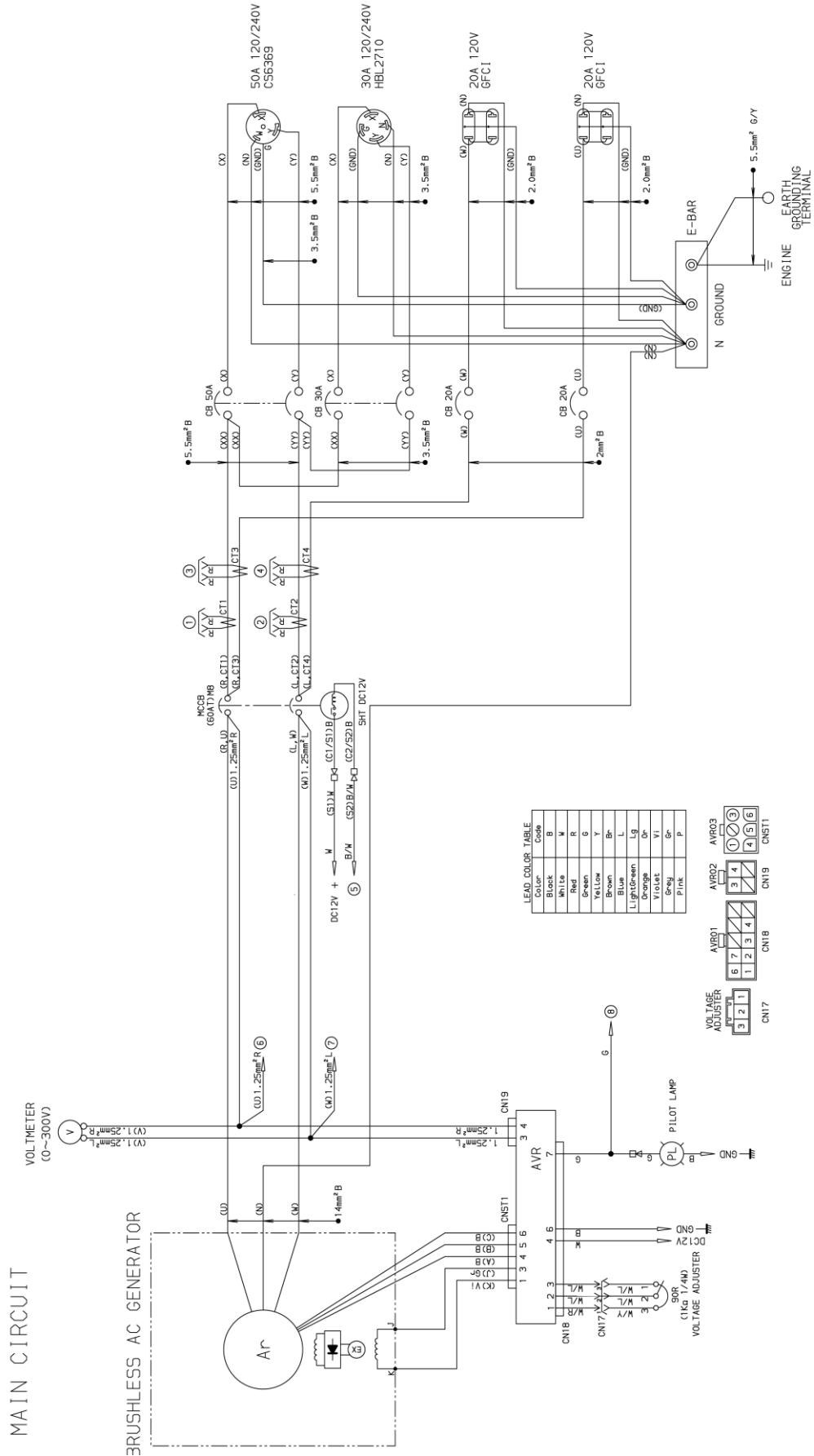

# 14. Engine Electrical Circuit Diagram

ENG. CONTROL CIRCUIT

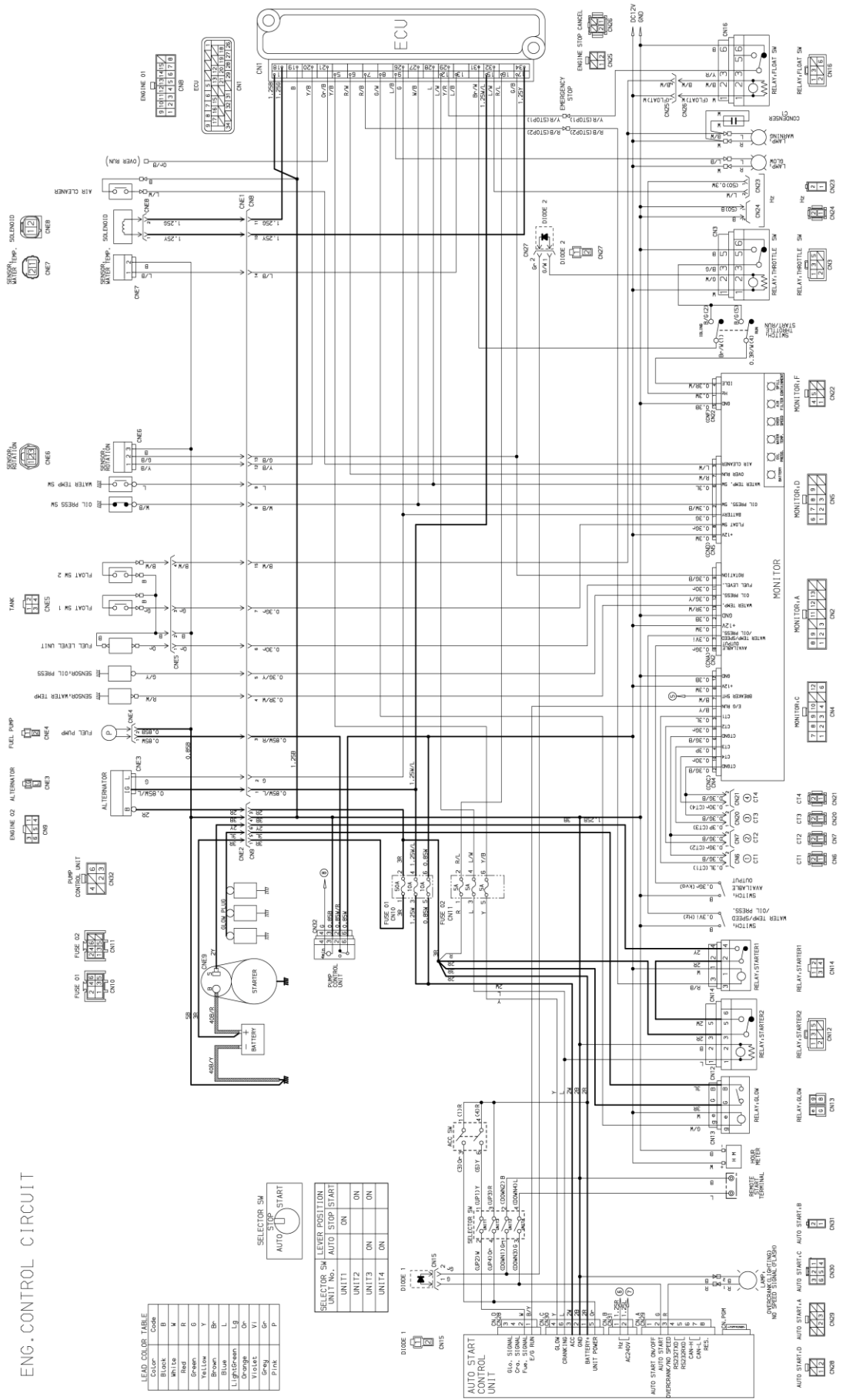

LEAD COLOR TABLE

Color	Code
Black	M
White	R
Red	G
Green	Y
Yellow	B
Blue	L
Light Green	LS
Orange	O
Violet	VI
Grey	GR
Pink	P

SELECTOR SW LEVER POSITION

UNIT No.	AUTO	STOP	START
UNIT1	ON	ON	ON
UNIT2	ON	ON	ON
UNIT3	ON	ON	ON
UNIT4	ON	ON	ON





**YAMABIKO CORPORATION**  
7-2 SUEHIROCHO 1-CHOME, OHME, TOKYO 198-8760, JAPAN  
PHONE: 81-428-32-6118. FAX: 81-428-32-6145.

**shindaiwa<sup>®</sup>**