

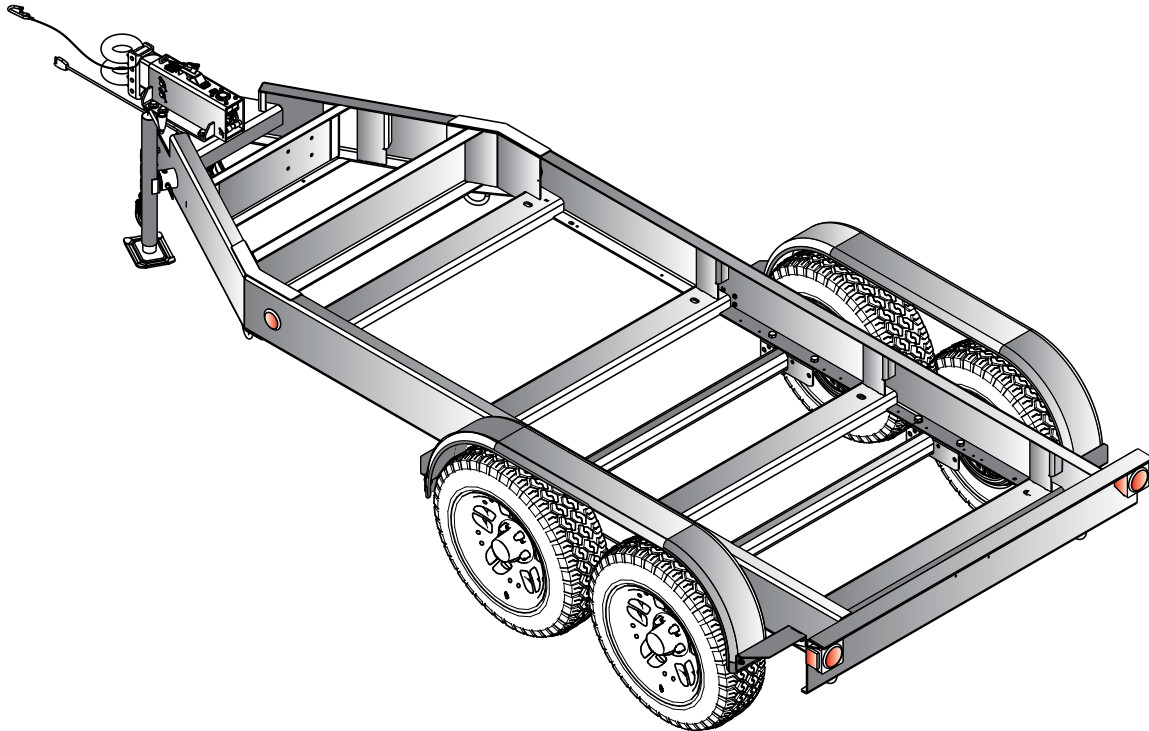

TRLR125US

MQ POWER Tandem Axle Trailer



TRLR125US Technical Data

Gross Vehicle Weight Rating (GVWR) — 10,000 lbs. (4,536 kg)	Tire Size — ST225/75R15 LR-D
Gross Axle Weight Rating (GAWR) — 5,000 lbs. (2,268 kg) (ea.)	Wheel Bolt Pattern — 6 Lug on 5.5 in
Actuator Rating — 12,500 lbs. (5,670 kg)	Tire Load Rating — 2,540 lbs (1,152 kg) (ea.)
Coupler Rating — See coupler options on back page.	Dimensions (LxWxH) — See back page.

STANDARD TRAILER EQUIPMENT

- Fits MQ Power Generator Models DCA125SSIU4F, DCA125USI3CAN
- Tandem-axle Design with Torsion Type Suspension
- Formed Channel for Generator Mounting and Support
- Replaceable, Bolt-on Hydraulic Brake Actuator
- Surge Hydraulic-actuated Drum Brakes (all axles)
- Hydraulic Uni-servo Drum Brakes with Free-backing Plates - 12-inch Cluster
- D.O.T. Steel Brake Lines, Brass Tees & Rubber Hydraulic Brake Hoses
- 4-hole Channel Allows 3-position, Adjustable Coupler Height; 4-inches O/A
- Tongue Mounted Swivel Jack with Flat Disc-foot (rated 5,000 pound lift)
- Replaceable, Bolt-on Steel Fender Brackets and Fenders
- Rugged Textured Black Powder-Coated Frame, Channel, Actuator and Fenders
- D.O.T. Approved Tail Lamps, Stop Lamps, Turn Signal Lamps, Side Marker Lamps
- Weatherproof, Rubber Armored, 2-piece Trailer Light Wiring Harness



TRLR125US

MQ POWER Tandem Axle Trailer

OPTIONAL TRAILER EQUIPMENT

- Bolt-on Electric Brake Coupler Plate with Electric-actuated Drum Brakes (all axles — self-adjusting brake actuators)
- Electric Breakaway Safety Device (electric-actuated brakes)
- Rear Stabilizer Stands
- Tongue Mounted Utility Storage Box
- Spare Tire with Locking Mount
- Anti-Theft Wheel Lock
- Center Mount Jack (rated 8,000 lbs./3,629 kg lift)
- 600V Transformer Kit

Coupler Options

3" Pintle Eye
25,000 lbs.

#EE36264



2-5/16" Ball Coupler
14,000 lbs.

#EE43253

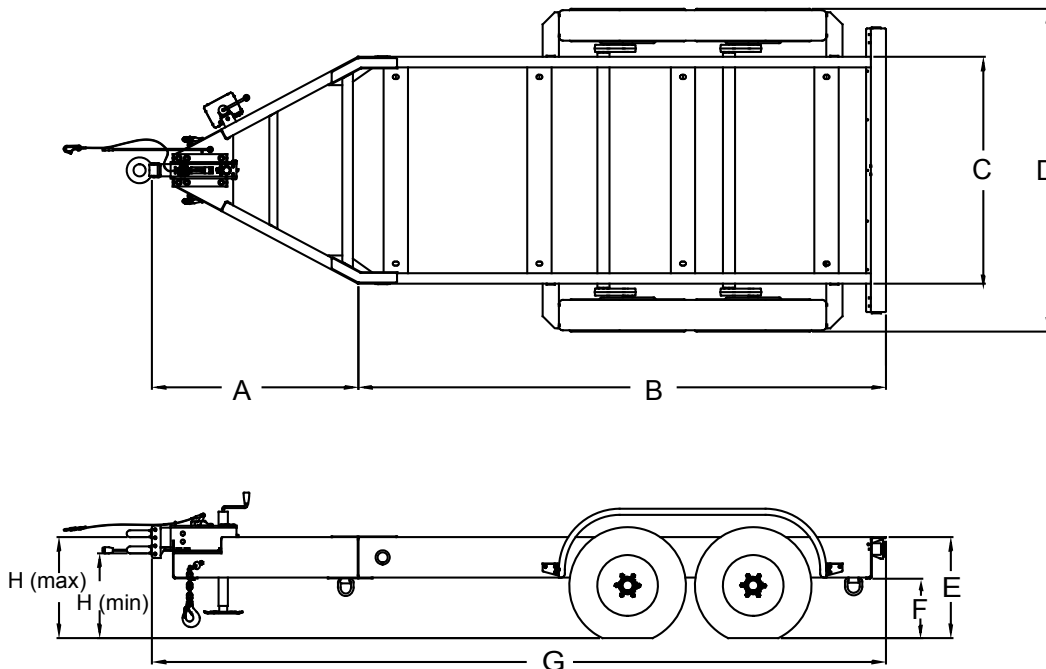
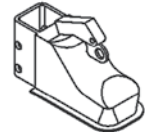

Trailer Dimensions								
A	B	C	D	E	F	G	H	
							MIN	MAX
50.93 in (1,293.6 mm)	130.25 in (3,308.3 mm)	56 in (1,422.4 mm)	79.67 in (2,023.6 mm)	24.93 in (633.2 mm)	14.68 in (372.9 mm)	181.18 in (4,602 mm)	20.94 in (531.9 mm)	24.94 in (633.5 mm)

Trailer Weight
1,722 lbs. (781 kg)*

* Weight is approximate

