

PARTS MANUAL



WHISPERWATT™ SERIES MODEL DCA36SPXU4F 60Hz GENERATOR (ISUZU 4LE2X DIESEL ENGINE)

PARTS LIST NO. M1871300304A

Revision #2 (02/10/17)

To find the latest revision of this
publication, visit our website at:
www.mqpower.com



THIS MANUAL MUST ACCOMPANY THE EQUIPMENT AT ALL TIMES.

DCA36SPXU4F 60 Hz Generator

Parts Ordering Procedures.....	3
Explanation Of Code In Remarks Column.....	4
Suggested Spare Parts	5

Component Drawings

Generator Assembly	6-7
Control Box 1 Assembly	8-9
Control Box 2 Assembly	10-11
Engine And Radiator Assembly	12-15
Output Terminal Assembly	16-17
Battery Assembly	18-19
Muffler Assembly	20-21
Fuel Tank Assembly	22-23
Battery Charger Assembly	24-25
Jacket Water Heater Assembly	26-27
Enclosure Assembly	28-33
Rubber Seals Assembly	34-35
Nameplate And Decals Assembly	36-37

Terms And Conditions Of Sale — Parts	38
--	----

NOTICE

Specifications and part numbers are subject to change without notice.

PARTS ORDERING PROCEDURES

Ordering parts has never been easier! Choose from three easy options:

Effective:
January 1st, 2006

www.multiquip.com



Order via Internet (Dealers Only):

Order parts on-line using Multiquip's SmartEquip website!

- View Parts Diagrams
- Order Parts
- Print Specification Information



If you have an MQ Account, to obtain a Username and Password, E-mail us at: parts@multiquip.com.

To obtain an MQ Account, contact your District Sales Manager for more information.

Goto www.multiquip.com and click on **Order Parts** to log in and save!

Use the **internet** and qualify for a **5% Discount** on *Standard orders* for all orders which include complete part numbers.*

Note: Discounts Are Subject To Change

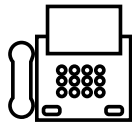

Order via Fax (Dealers Only):

All customers are welcome to order parts via Fax.

Domestic (US) Customers dial:
1-800-6-PARTS-7 (800-672-7877)

Fax your order in and qualify for a **2% Discount** on *Standard orders* for all orders which include complete part numbers.*

Note: Discounts Are Subject To Change



Order via Phone: Domestic (US) Dealers Call:
1-800-427-1244

Non-Dealer Customers:

Contact your local Multiquip Dealer for parts or call 800-427-1244 for help in locating a dealer near you.



International Customers should contact their local Multiquip Representatives for Parts Ordering information.

When ordering parts, please supply:

- | | |
|---|--|
| <input type="checkbox"/> Dealer Account Number | <input type="checkbox"/> Specify Preferred Method of Shipment: |
| <input type="checkbox"/> Dealer Name and Address | <input checked="" type="checkbox"/> UPS/Fed Ex <input checked="" type="checkbox"/> DHL |
| <input type="checkbox"/> Shipping Address (if different than billing address) | <input type="checkbox"/> Priority One <input checked="" type="checkbox"/> Truck |
| <input type="checkbox"/> Return Fax Number | <input type="checkbox"/> Ground |
| <input type="checkbox"/> Applicable Model Number | <input type="checkbox"/> Next Day |
| <input type="checkbox"/> Quantity, Part Number and Description of Each Part | <input type="checkbox"/> Second/Third Day |

NOTICE

All orders are treated as *Standard Orders* and will ship the same day if received prior to 3PM PST.

WE ACCEPT ALL MAJOR CREDIT CARDS!



EXPLANATION OF CODE IN REMARKS COLUMN

The following section explains the different symbols and remarks used in the Parts section of this manual. Use the help numbers found on the back page of the manual if there are any questions.

NOTICE

The contents and part numbers listed in the parts section are subject to change **without notice**. Multiquip does not guarantee the availability of the parts listed.

SAMPLE PARTS LIST

NO.	PART NO.	PART NAME	QTY.	REMARKS
1	12345	BOLT	1	INCLUDES ITEMS W/%
2%		WASHER, 1/4 IN.		NOT SOLD SEPARATELY
2%	12347	WASHER, 3/8 IN. ...	1	MQ-45T ONLY
3	12348	HOSE	A/R	MAKE LOCALLY
4	12349	BEARING	1	S/N 2345B AND ABOVE

NO. Column

Unique Symbols — All items with same unique symbol (@, #, +, %, or >) in the number column belong to the same assembly or kit, which is indicated by a note in the “Remarks” column.

Duplicate Item Numbers — Duplicate numbers indicate multiple part numbers, which are in effect for the same general item, such as different size saw blade guards in use or a part that has been updated on newer versions of the same machine.

NOTICE

When ordering a part that has more than one item number listed, check the remarks column for help in determining the proper part to order.

PART NO. Column

Numbers Used — Part numbers can be indicated by a number, a blank entry, or TBD.

TBD (To Be Determined) is generally used to show a part that has not been assigned a formal part number at the time of publication.

A blank entry generally indicates that the item is not sold separately or is not sold by Multiquip. Other entries will be clarified in the “Remarks” Column.

QTY. Column

Numbers Used — Item quantity can be indicated by a number, a blank entry, or A/R.

A/R (As Required) is generally used for hoses or other parts that are sold in bulk and cut to length.

A blank entry generally indicates that the item is not sold separately. Other entries will be clarified in the “Remarks” Column.

REMARKS Column

Some of the most common notes found in the “Remarks” Column are listed below. Other additional notes needed to describe the item can also be shown.

Assembly/Kit — All items on the parts list with the same unique symbol will be included when this item is purchased.

Indicated by:

“INCLUDES ITEMS W/(unique symbol)”

Serial Number Break — Used to list an effective serial number range where a particular part is used.

Indicated by:

“S/N XXXXX AND BELOW”

“S/N XXXX AND ABOVE”

“S/N XXXX TO S/N XXX”

Specific Model Number Use — Indicates that the part is used only with the specific model number or model number variant listed. It can also be used to show a part is NOT used on a specific model or model number variant.

Indicated by:

“XXXXX ONLY”

“NOT USED ON XXXX”

“Make/Obtain Locally” — Indicates that the part can be purchased at any hardware shop or made out of available items. Examples include battery cables, shims, and certain washers and nuts.

“Not Sold Separately” — Indicates that an item cannot be purchased as a separate item and is either part of an assembly/kit that can be purchased, or is not available for sale through Multiquip.

SUGGESTED SPARE PARTS

DCA36SPXU4F WHISPERWATT GENERATOR WITH ISUZU 4LE2X DIESEL ENGINE

1 TO 3 UNITS

Qty.	P/N	Description
3.....	PMAF25436.....	AIR FILTER (PRIMARY)
3.....	P822769.....	ELEMENT, AIR (SECONDARY)
3.....	8980756761.....	OIL FILTER
3.....	8980490340.....	V-BELT
5.....	8982402790.....	ELEMENT, FUEL FILTER (PRE)
5.....	8982402800.....	ELEMENT, FUEL FILTER (MAIN)
5.....	8981731650.....	KIT, FEED PUMP FILTER
1.....	M1311500603.....	RADIATOR HOSE, UPPER
1.....	M1311500703.....	RADIATOR HOSE, LOWER
2.....	0601870440.....	CIRCUIT BREAKER, 1P, 20 AMP
2.....	0601870441.....	CIRCUIT BREAKER, 2P, 50 AMP
1.....	0601820626.....	AUTOMATIC VOLTAGE REGULATOR
2.....	0601810277.....	BULB, LAMPS
1.....	LY2DUS12VDC	RELAY, W/DIODE
1.....	0601802133.....	FUSE, 5 AMP
1.....	Y0601806684	FUSE, 8 AMP
3.....	0601802149.....	FUSE, 10 AMP
2.....	0601806671.....	FUSE, 15 AMP
1.....	0601806644.....	FUSE, 30 AMP
1.....	0601806640	FUSE, 65 AMP

NOTICE

Part number on this Suggested Spare Parts list may supersede/replace the P/N shown in the text pages of this book.

GENERATOR ASSY.

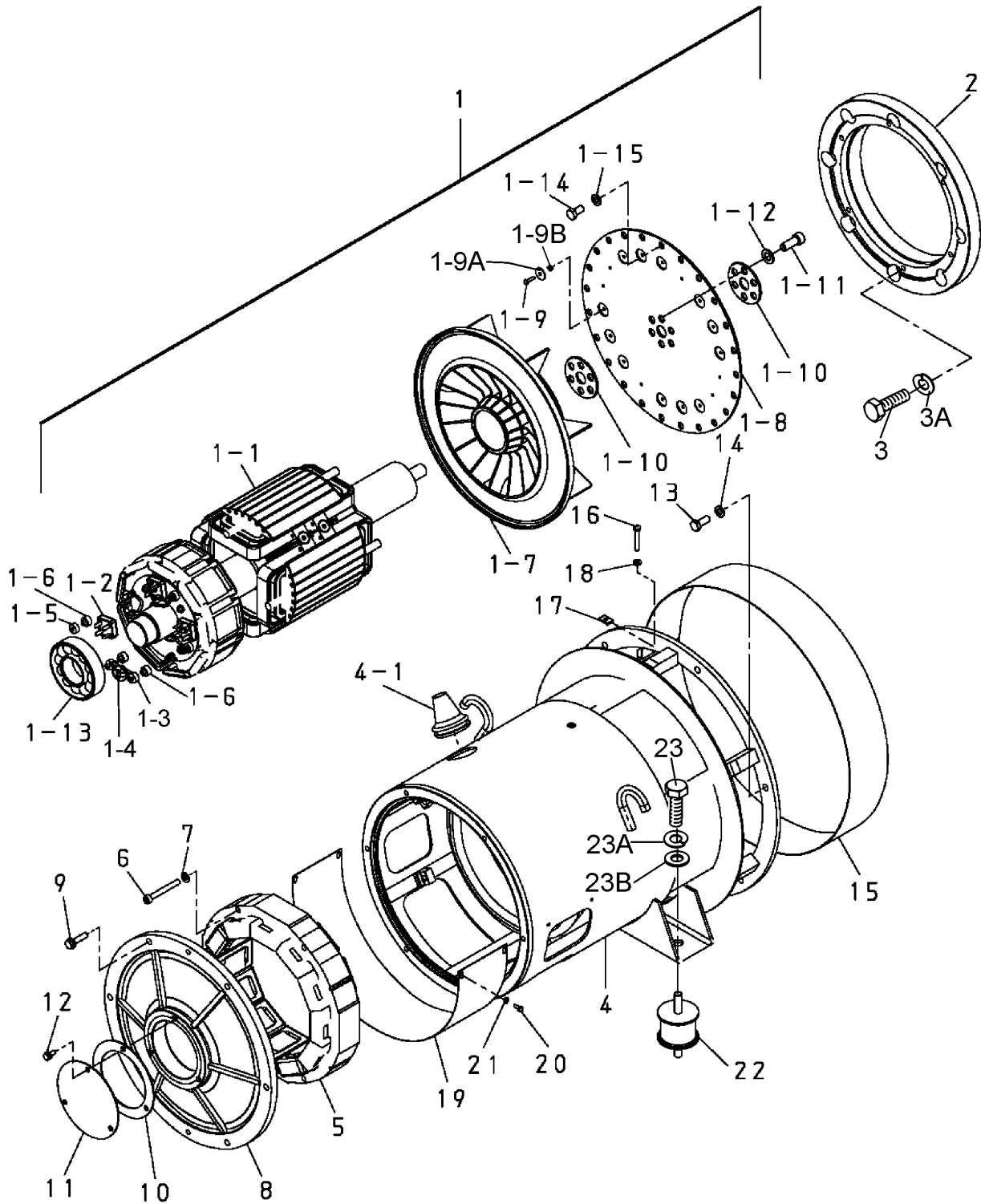

GENERATOR ASSY.

<u>NO.</u>	<u>PART NO.</u>	<u>PART NAME</u>	<u>QTY.</u>	<u>REMARKS</u>
1	B4110100402	ROTOR ASSY.	1	INCLUDES ITEMS W/#
1-1#		FIELD ASSY.	1	
1-2#	0601820083	RECTIFIER	3	
1-3#	0601822664	ZNR	1	
1-4#	B3120100804	HOLDER, ZNR	1	
1-5#	B3120100604	INSULATOR WASHER	3	
1-6#	B3120100704	INSULATOR WASHER	5	
1-7#	B3111100603	FAN	1	
1-8#	B3163100204	COUPLING DISK.....	3.....	PURCHASE SET OF 1-9 WHEN ORDERING.
1-9#	0010304016	HEX HEAD BOLT	1	
1-9A#	B4163700004	BALANCING WEIGHT	1	
1-9B#	0204004000	U NUT	1	
1-10#	B3163200104	COUPLING WASHER	2	
1-11#	0342612030	HEX SOCKET HEAD CAP SCREW	6	
1-12#	0046512000	WASHER, FLAT	6	
1-13#	0071906309	BEARING	1	
1-14#	014208020	HEX HEAD BOLT.....	6.....	REPLACES P/N 0010308020
1-15#	0042508000	WASHER, LOCK	6	
2	M1164400203	COUPLING RING	1	
3	012210035	HEX HEAD BOLT.....	8.....	REPLACES P/N 0010310035
3A	0040010000	WASHER, LOCK	8	
4	B4130100903	STATOR ASSY.	1	
4-1	0845041904	GROMMET	1	
5	B3137000803	FIELD ASSY., EXCITER	1	
6	0016008060	HEX SOCKET HEAD CAP SCREW	4	
7	0042508000	WASHER, LOCK	4	
8	B3153000513	END BRACKET	1	
9	0017108035	HEX HEAD BOLT	6	
10	B3153400504	PACKING	1	
11	B3153400404	COVER, SUCTION	1	
12	0017106016	HEX HEAD BOLT	3	
13	0105091025	HEX HEAD BOLT.....	6.....	REPLACES P/N 0010310025
14	030210250	WASHER, LOCK.....	6.....	REPLACES P/N 0042510000
15	B3131300004	COVER, END BRACKET	1	
16	0340406040	HEX HEAD BOLT	1	
17	020106050	NUT.....	1.....	REPLACES P/N 0600815000
18	952404470	WASHER, FLAT	1.....	REPLACES P/N 0041206000
19	B3131300804	COVER, END BRACKET	1	
20	0029205012	MACHINE SCREW	4	
21	58151	WASHER, FLAT	4.....	REPLACES P/N 0041205000
22	Y0605000407	RUBBER SUSPENSION	2	
23	0030012000	HEX. NUT	2	
23A	0040012000	WASHER, LOCK	2	
23B	031112230	WASHER, FLAT	2.....	REPLACES P/N 0041212000

CONTROL BOX 1 ASSY.

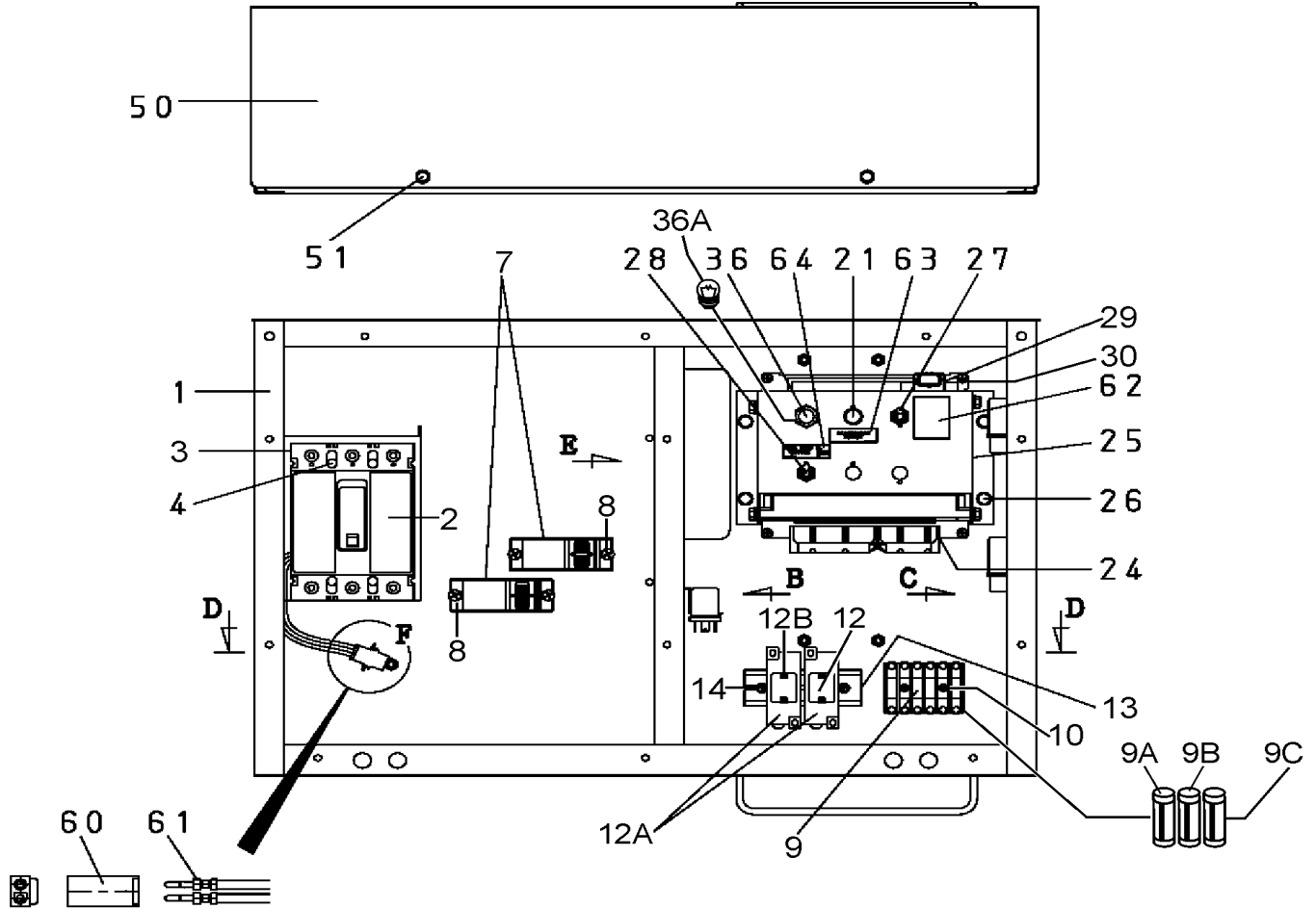

DETAIL-F

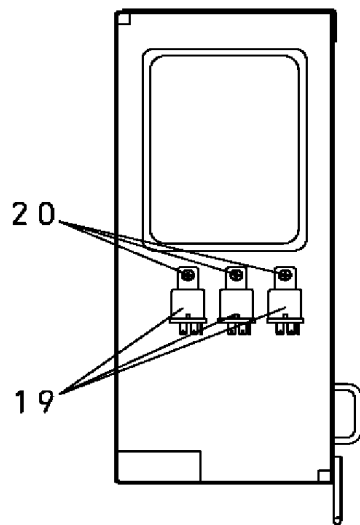

VIEW-B

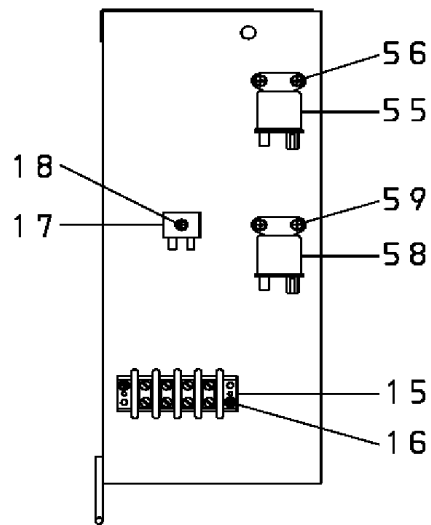

VIEW-C

CONTROL BOX1 ASSY.

<u>NO.</u>	<u>PART NO.</u>	<u>PART NAME</u>	<u>QTY.</u>	<u>REMARKS</u>
1	M1214000602	CONTROL BOX	1	
2	0601870434	CIRCUIT BREAKER 3P 150A	1	
3	0601870490	END CAP KIT	2	
4	0021004040	MACHINE SCREW	4	
7	0601801124	CURRENT TRANSFORMER	2	
8	011206020	MACHINE SCREW	4	REPLACES P/N 0027106020
9	Y0601802214	HOLDER, FUSE	1	
9A	0601806671	FUSE 15A	2	
9B	0601802149	FUSE 10A	3	
9C	0601802133	FUSE 5A	1	
10	0027103015	MACHINE SCREW	2	
12	LY2DUS12VDC	RELAY W/DIODE	2	REPLACES P/N 0601827656
12A	PTF08A	BASE	2	REPLACES P/N 0601823109
12B	PYCA1	CLIP	4	REPLACES P/N 0601824400
13	Y0290000100	MOUNTING RAIL	1	
14	7538070	MACHINE SCREW	2	REPLACES P/N 0027104015
15	0601815153	TERMINAL BLOCK	1	
16	7538070	MACHINE SCREW	2	REPLACES P/N 0027104015
17	0601821370	RECTIFIER	2	REPLACES P/N 0601823240
18	0027104030	MACHINE SCREW	1	
19	5825500290	RELAY	3	REPLACES P/N 0602201400
20	0027105010	MACHINE SCREW	3	
21	0601831205	PUSH BUTTON SWITCH	1	
24	8982201570	ENGINE CONTROLLER (ECM)	1	REPLACES P/N Y0602202669
25	M1214600204	CONTROLLER BRACKET	1	
26	011106015	HEX HEAD BOLT	8	REPLACES P/N 0016906015
27	0601830710	DIAGNOSTIC SWITCH	1	
28	0601830762	FUEL PUMP SWITCH	1	
29	8972177780	BAROMETRIC PRESSURE SENSOR	1	REPLACES P/N 0602130220
30	0027105015	MACHINE SCREW	2	
36	0602103092	ALARM LAMP	1	
36A	0601810277	BULB	1	
50	M1213500704	CONTROL BOX COVER	1	
51	011106015	HEX HEAD BOLT	4	REPLACES P/N 0016906015
55	8942481610	RELAY, STARTER	1	REPLACES P/N 0602202502
56	0027105010	MACHINE SCREW	2	
58	8970119490	GLOW PLUG RELAY	1	REPLACES P/N 0602202685
59	0027105010	MACHINE SCREW	2	
60	0601812626	PLUG	1	
61	0601812712	PINS (MALE)	2	
62	M9520000904	DECAL; DIAGNOSTIC SWITCH	1	
63	M9520001104	DECAL; DIAGNOSTIC BUTTON	1	
64	M9520002104	DECAL; FUEL PUMP SWITCH	1	

CONTROL BOX 2 ASSY.

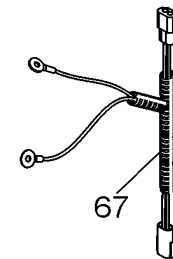
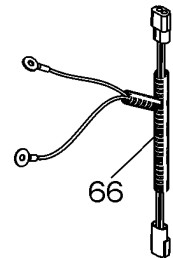
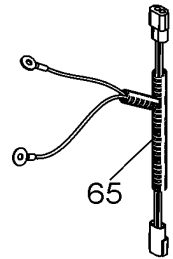
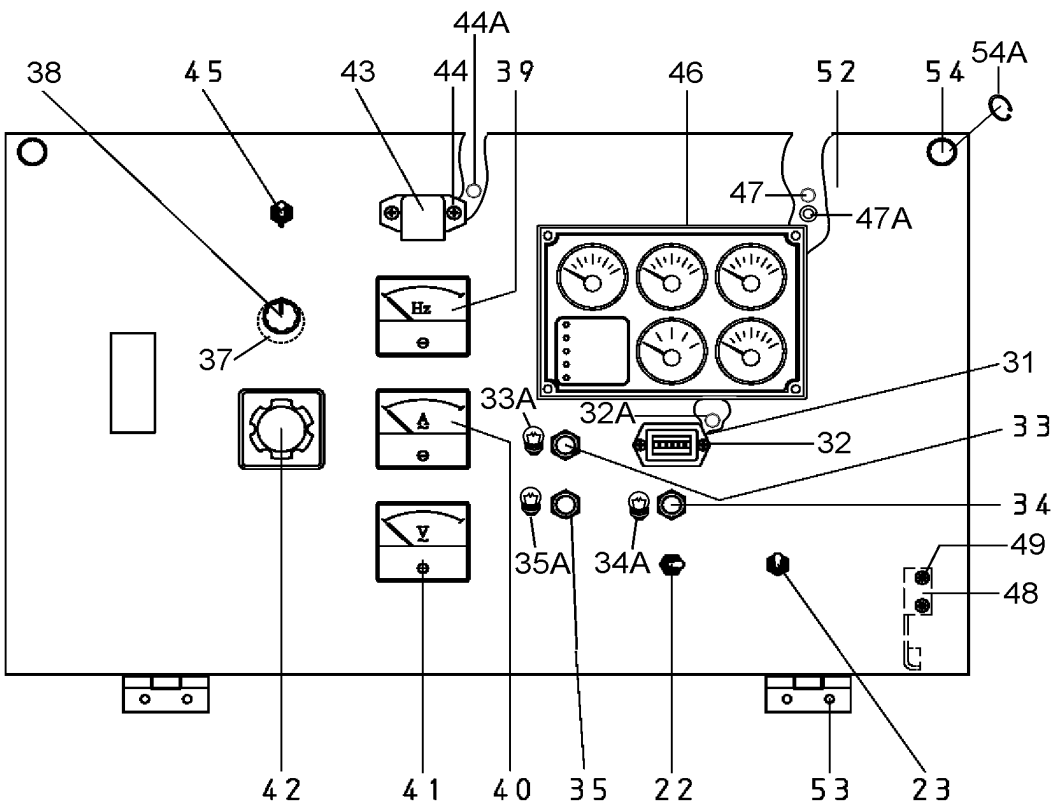
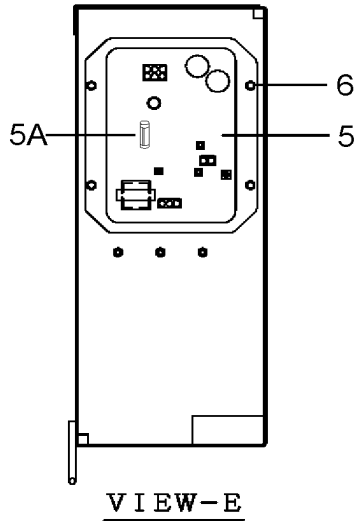
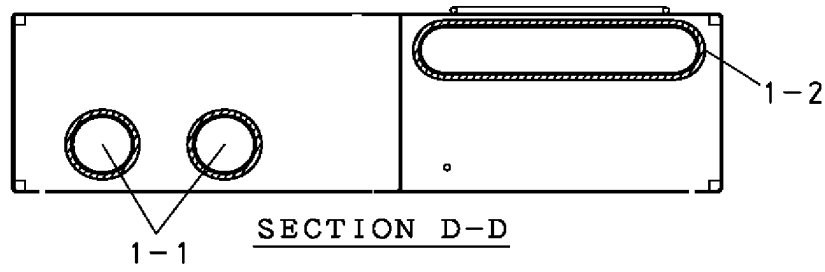

CONTROL BOX 2 ASSY.

<u>NO.</u>	<u>PART NO.</u>	<u>PART NAME</u>	<u>QTY.</u>	<u>REMARKS</u>
1-1	0330000180	EDGING	2	
1-2	0330000615	EDGING	1	
5	0601820626	AUTOMATIC VOLTAGE REGULATOR	1	
5A	Y0601806684	FUSE 250V 7A	1	
6	0027105015	MACHINE SCREW	4	
11	M2357202104	FUSE HOLDER	1	
11A	0601806644	FUSE 30A	1	
22	82608	AUTO START/STOP SWITCH	1	REPLACES P/N 0601831340
23	0601830710	ENGINE SPEED SWITCH	1	
31	0601800682	HOUR METER	1	
32	0027103015	MACHINE SCREW	2	
32A	0207003000	SELF-LOCKING NUT	2	
33	0602103092	FUEL LEAK DETECTED ALARM LAMP	1	
33A	0601810277	BULB	1	
34	0602103092	PREHEAT LAMP	1	
34A	0601810277	BULB	1	
35	0602103092	WARNING LAMP	1	
35A	0601810277	BULB	1	
37	0601840073	RHEOSTAT (VOLT. REG.) 2W 1K OHM	1	
38	0601840100	KNOB.....	1	REPLACES P/N 0601840121
39	0601807641	FREQUENCY METER	1	
40	0601806845	AC AMMETER	1	
41	0601800271	AC VOLTMETER	1	
42	0601801040	CHANGE-OVER SWITCH, AMMETER	1	
43	Y0601810170	PANEL LIGHT	1	
44	0027104020	MACHINE SCREW	2	
44A	OEMAA8	SELF-LOCKING NUT	2	REPLACES P/N 0207004000
45	0601830710	PANEL LIGHT SWITCH	1	
46	Y0602202653	CONTROLLER	1	
47	Y0206707000	HEX NUT	4	
47A	Y0044807000	WASHER, LOCK	4	
48	M1224100104	STOPPER	1	
49	0027105010	MACHINE SCREW	2	
52	M1224000203	CONTROL PANEL	1	
53	0027105010	MACHINE SCREW	4	
54	M9220100004	SET SCREW	2	
54A	0080200007	E-SNAP RING	2	
57	0601806640	FUSE 65A	1	
65	M1247702104	WIRE HARNESS, GENERATOR	1	
66	M1358200902	WIRE HARNESS, ENGINE	1	
67	M1358200302	WIRE HARNESS, CONTROLLER	1	

ENGINE AND RADIATOR ASSY.

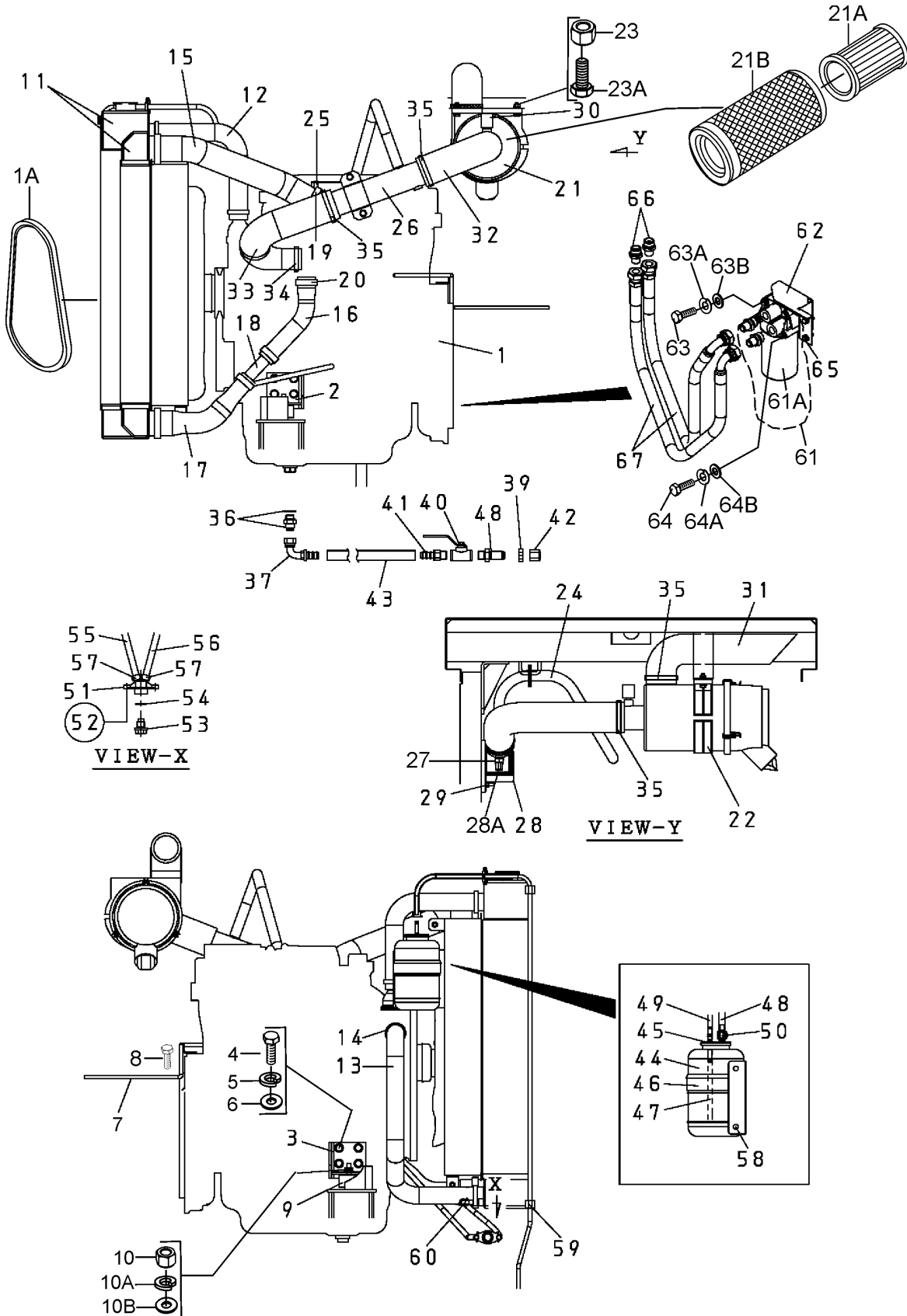

ENGINE AND RADIATOR ASSY.

<u>NO.</u>	<u>PART NO.</u>	<u>PART NAME</u>	<u>QTY.</u>	<u>REMARKS</u>
1	M1924200084	ENGINE, ISUZU 4LE2X	1	
1A	8980490340	V-BELT	1	
2	M1304200004	ENGINE FOOT	1	
3	M1304200104	ENGINE FOOT	1	
4	0105091025	HEX HEAD BOLT.....	8.....	REPLACES P/N 0010310025
5	0040010000	WASHER, LOCK	8	
6	031110160	WASHER, FLAT.....	8.....	REPLACES P/N 0041210000
7	M1358300403	CLAMPER ROD	1	
8	012210020	HEX HEAD BOLT.....	2.....	REPLACES P/N 0017110020
9	Y0605000407	RUBBER SUSPENSION	2	
10	0030012000	HEX NUT	2	
10A	0040012000	WASHER, LOCK	2	
10B	031112230	WASHER, FLAT.....	2.....	REPLACES P/N 0041212000
11	Y0602012904	RADIATOR AND INTER-COOLER	1	
12	M1311500603	RADIATOR HOSE, UPPER	1	
13	M1311500703	RADIATOR HOSE, LOWER	1	
14	0605515149	HOSE BAND	4	
15	M1311500803	INTER-COOLER HOSE UPPER	1	
16	M1311500903	INTER-COOLER HOSE, MIDDLE	1	
17	M1311501003	INTER-COOLER HOSE, LOWER	1	
18	M1311400004	INTER-COOLER PIPE	1	
19	Y0605515300	HOSE BAND	3	
20	Y0605515264	HOSE BAND	3	
21	Y0602046590	AIR CLEANER	1	
21A	PMAF25436	AIR FILTER PRIMARY	1	
21B	P822769	ELEMENT, AIR SECONDARY	1	
22	Y0602040553	AIR CLEANER BAND	1	
23	011208030	HEX HEAD BOLT.....	2.....	REPLACES P/N 0016908030
23A	020108060	SELF-LOCKING-NUT.....	2.....	REPLACES P/N 0207008000
24	0269200640	PUSH-LOCK-HOSE	1	
25	0605515198	HOSE BAND	2	
26	M1374000104	AIR CLEANER PIPE	1	
27	8121468300	INLET AIR TEMPERATURE SENSOR.....	1.....	REPLACES P/N 0603210240
28	M1374200204	BRACKET, AIR CLEANER PIPE	1	
28A	Y0222100060	RUBBER SEAL	1	
29	011008020	HEX HEAD BOLT.....	2.....	REPLACES P/N 0016908020
30	0602040651	INDICATOR, AIR CLEANER	1	
31	M1374100703	AIR CLEANER HOSE	1	
32	M1374100503	AIR CLEANER HOSE	1	
33	M1374100603	AIR CLEANER HOSE	1	
34	0605515147	HOSE BAND	1	
35	9500202080	HOSE BAND.....	4.....	REPLACES P/N 0605515178
36	0602022581	ADAPTER	1	

ENGINE AND RADIATOR ASSY. (CONTINUED)

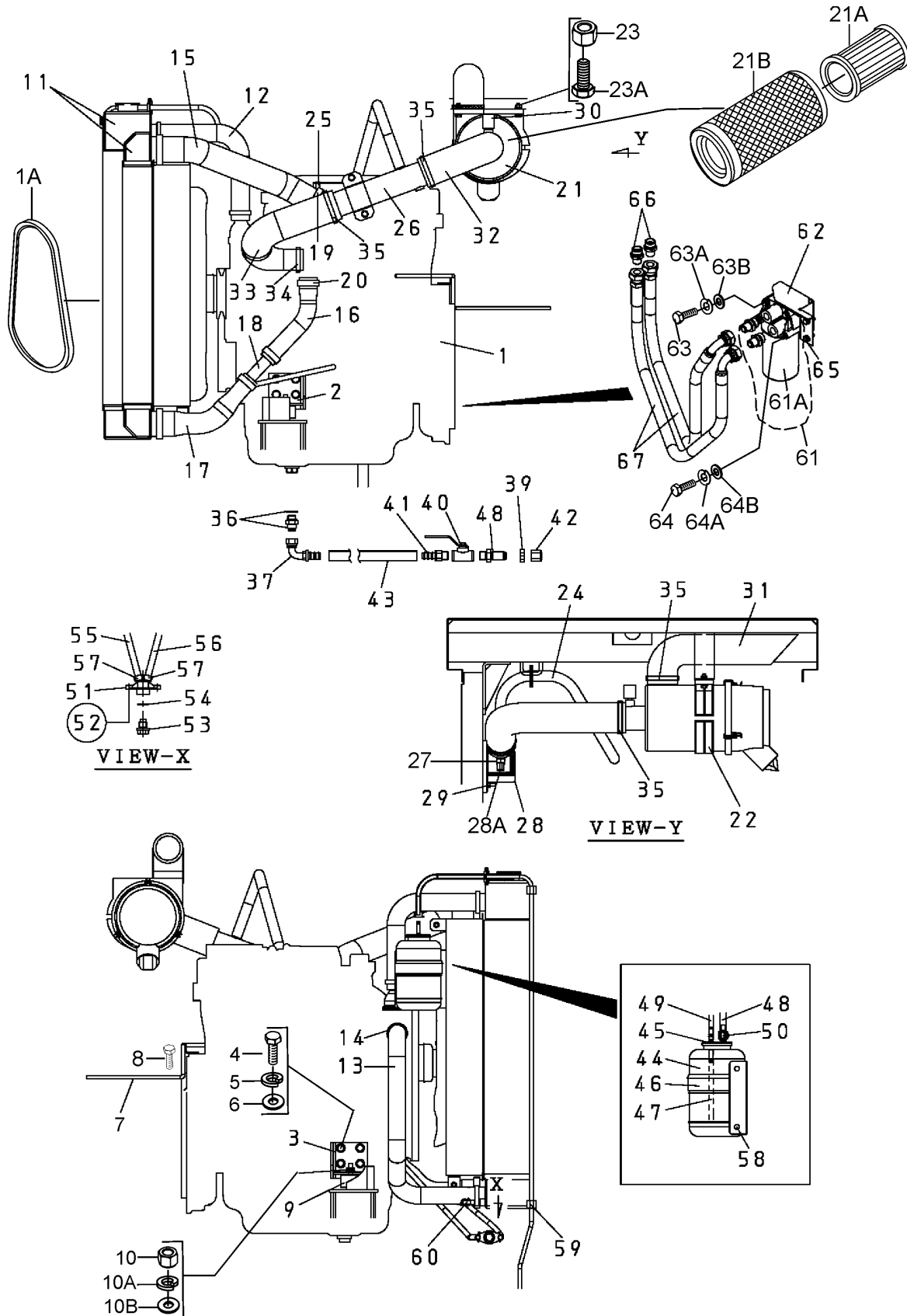

ENGINE AND RADIATOR ASSY. (CONTINUED)

<u>NO.</u>	<u>PART NO.</u>	<u>PART NAME</u>	<u>QTY.</u>	<u>REMARKS</u>
37	0602022561	90° ELBOW	1	
39	0603300285	LOCKNUT	1	
40	0605511395	VALVE	1	
41	0603306395	HOSE JOINT	1	
42	0602021070	CAP	1	
43	Y0269200490	DRAIN HOSE	1	
44	0845031303	RESERVE TANK.....	1.....	REPLACES P/N M9300000103
45	0802081104	CAP, RESERVE TANK.....	1.....	REPLACES P/N M9300100003
46	M2316100304	BRACKET, RESERVE TANK	1	
47	0199100175	HOSE	1	
48	0199900450	OVER FLOW HOSE	1	
49	0193601500	OVER FLOW HOSE	1	
50	0605515189	HOSE BAND	2	
51	1622014103	DRAIN JOINT.....	1.....	REPLACES P/N M9602000003
52	011206020	HEX HEAD BOLT.....	2.....	REPLACES P/N 0016906020
53	0802011104	DRAIN BOLT.....	1.....	REPLACES P/N M9200200004
54	0150000018	O-RING	1	
55	Y0199900440	DRAIN HOSE	1	
56	Y0199901310	DRAIN HOSE	1	
57	0605515189	HOSE BAND	4	
58	011008020	HEX HEAD BOLT.....	2.....	REPLACES P/N 0016908020
59	0602220911	CLAMP	2	
60	Y0605512183	HOSE JOINT	1	
61	8980756710	OIL FILTER ASSY.....	1.....	INCLUDES ITEMS W/\$
61A\$	8980756761	OIL FILTER	1	
62	M1324400004	BRACKET, OIL FILTER	1	
63	Y0010108090	HEX HEAD BOLT	2	
63A	0040008000	WASHER, LOCK	2	
63B	0401450080	WASHER, FLAT.....	2.....	REPLACES P/N 0041208000
64	Y0010108110	HEX HEAD BOLT	2	
64A	0040008000	WASHER, LOCK	2	
64B	0401450080	WASHER, FLAT.....	2.....	REPLACES P/N 0041208000
65	011208025	HEX HEAD BOLT.....	2.....	REPLACES P/N 0016908025
66	Y0602022534	STRAIGHT ADAPTER	4	
67	M1324300004	OIL FILTER HOSE	2	

OUTPUT TERMINAL ASSY.

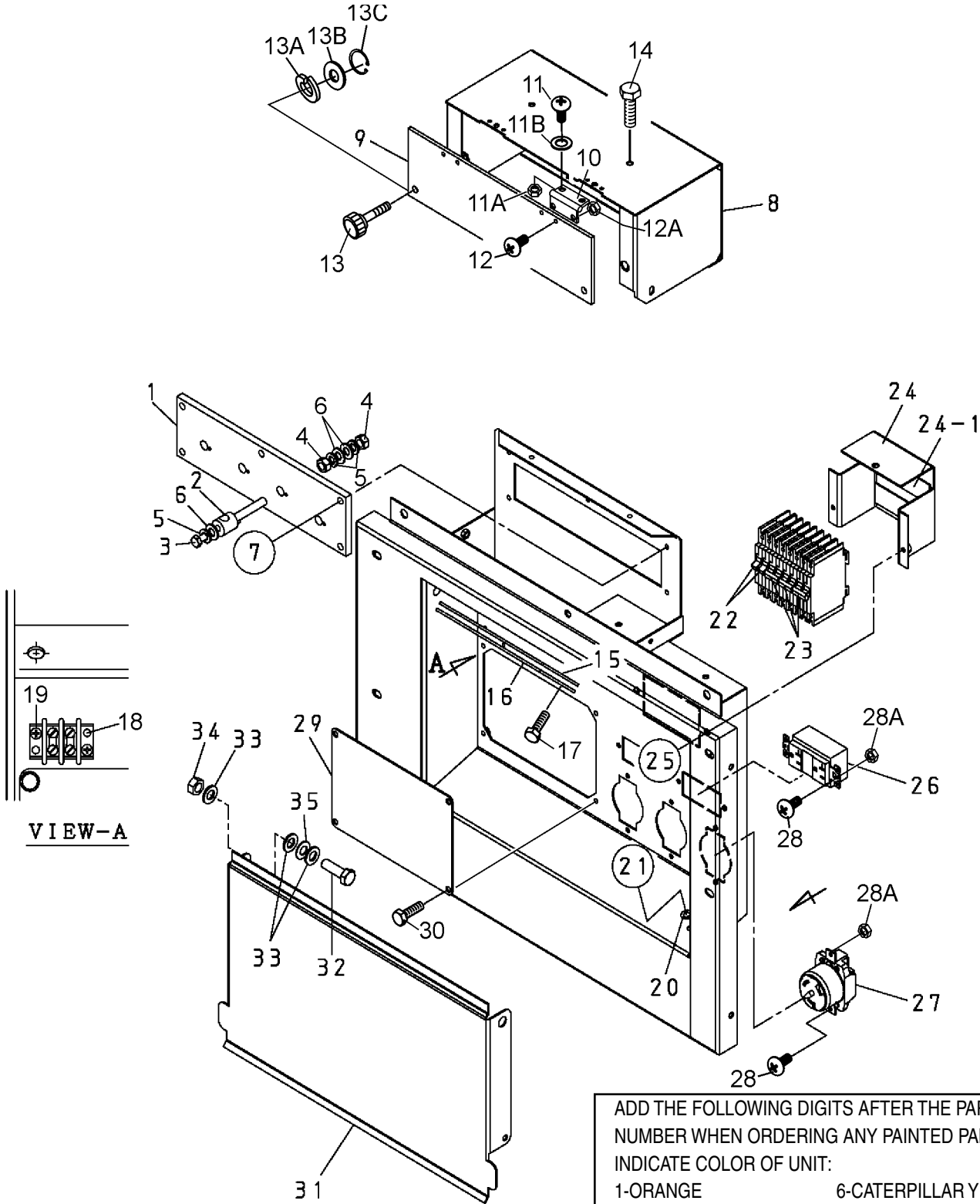

ADD THE FOLLOWING DIGITS AFTER THE PART NUMBER WHEN ORDERING ANY PAINTED PANEL TO INDICATE COLOR OF UNIT:

1-ORANGE	6-CATERPILLAR YELLOW
2-WHITE	7-CATO GOLD
3-SPECTRUM GREY	8-RED
4-SUNBELT GREEN	9-DESERT TAN
5-BLACK	

THE SERIAL NUMBER MAY BE REQUIRED.

OUTPUT TERMINAL ASSY.

<u>NO.</u>	<u>PART NO.</u>	<u>PART NAME</u>	<u>QTY.</u>	<u>REMARKS</u>
1	M1230700303	TERMINAL PANEL	1	
2	M2233000004	OUTPUT TERMINAL BOLT	4	
3	M2233100004	TIE BOLT	4	
4	0039312000	HEX NUT	8	
5	0040012000	WASHER, LOCK	12	
6	0041412000	WASHER, FLAT	16	
7	011208030	HEX HEAD BOLT.....	5.....	REPLACES P/N 0017108030
8	M1237100303	3-PHASE OUTPUT TERMINAL COVER	1	
9	M1236100704	OUTPUT WINDOW	1	
10	0605010040	HINGE	2	
11	0027103010	MACHINE SCREW	4	
11A	0207003000	HEX NUT	4.....	REPLACES P/N 0030003000
11B	0041203000	WASHER, FLAT	4	
12	0027103010	MACHINE SCREW	4.....	REPLACES P/N 0030003000
12A	0207003000	HEX NUT	4	
13	M9220100804	SET SCREW	2	
13A	0040006000	WASHER, LOCK	2	
13B	952404470	WASHER, FLAT	2.....	REPLACES P/N 0041206000
13C	0080200005	E-SNAP RING	2	
14	011106015	HEX HEAD BOLT.....	4.....	REPLACES P/N 0016906015
15	M1236400004	CABLE OUTLET COVER	1	
16	M1236300004	SUPPORTER, CABLE OUTLET COVER	1	
17	011206020	HEX. HEAD BOLT	6.....	REPLACES P/N 0016906020
18	0601815194	TERMINAL BLOCK	1	
19	7538070	MACHINE SCREW	2.....	REPLACES P/N 0027104015
20	0040508000	TOOTHED WASHER	1	
21	0019208020	HEX HEAD BOLT	1	
22	0601870440	CIRCUIT BREAKER 1P 20A	2	
23	0601870441	CIRCUIT BREAKER 2P 50A	3	
24	M1260700504	BREAKER FITTING COVER	1	
24-1	Y0222100105	CUSHION RUBBER	2	
25	011206020	HEX HEAD BOLT.....	2.....	REPLACES P/N 0016906020
26	0601814013	RECEPTACLE 125V 20A	2	
27	Y0601814014	RECEPTACLE 250V 50A	3	
28	7538070	MACHINE SCREW	10.....	REPLACES P/N 0027104015
28A	OEMAA8	HEX NUT	10.....	REPLACES P/N 0207004000
29	M1236400104	COVER	1	
30	011106015	HEX HEAD BOLT.....	4.....	REPLACES P/N 0016906015
31	M1237100203	TERMINAL COVER	1	
32	012212045	HEX HEAD BOLT.....	2.....	REPLACES P/N 0010112045
33	031112230	WASHER, FLAT	6.....	REPLACES P/N 0041212000
34	0030012000	HEX NUT	2	
35	0605050060	CONICAL WASHER LOCK	2	

BATTERY ASSY.

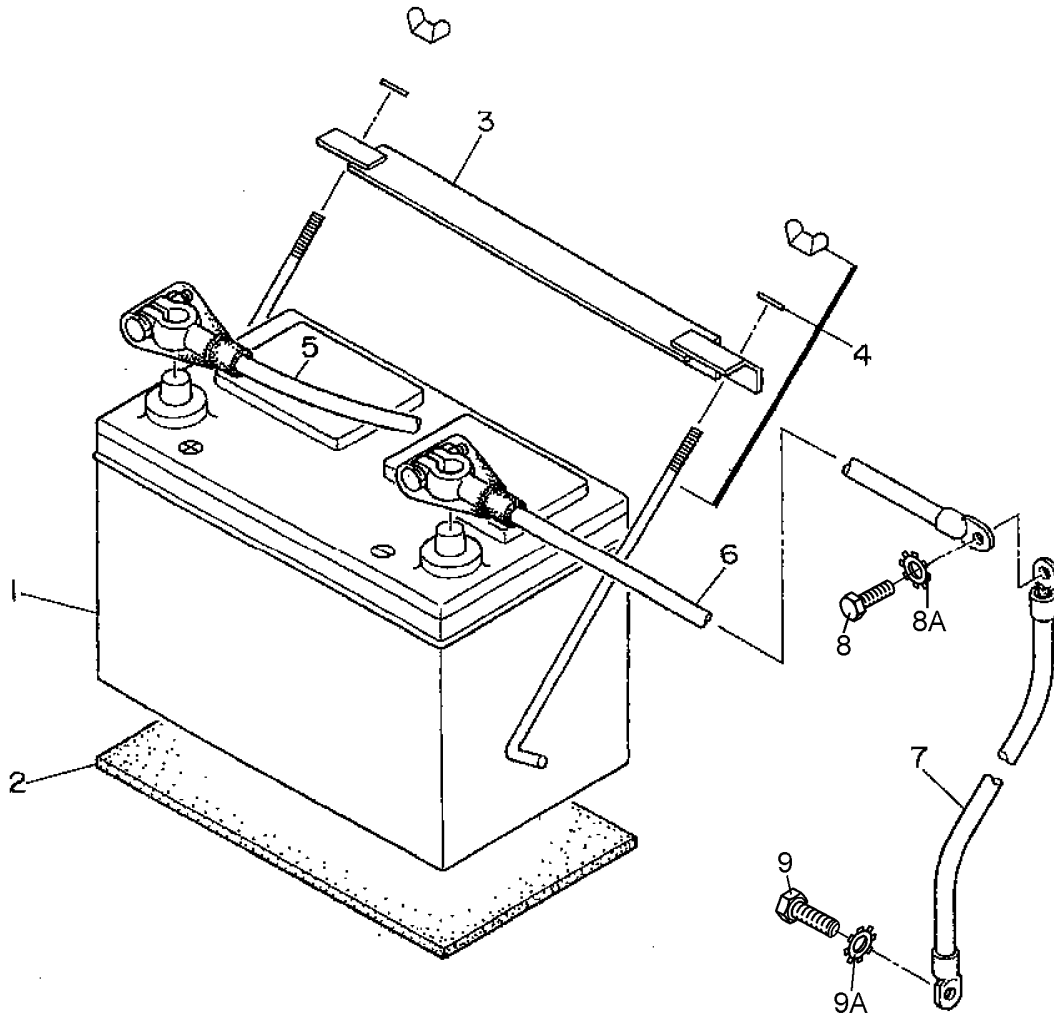

BATTERY ASSY.

<u>NO.</u>	<u>PART NO.</u>	<u>PART NAME</u>	<u>QTY.</u>	<u>REMARKS</u>
1	0602220199	BATTERY	1	
2	M9310500014	BATTERY SHEET	1	
3	M9103000304	BATTERY BAND	1	
4	0602220920	BATTERY BOLT SET	2	
5	M2346900204	BATTERY CABLE	1	
6	M2346900304	BATTERY CABLE	1	
7		CABLE	1	PURCHASE LOCALLY
8	0017112025	HEX HEAD BOLT	1	
8A	0040512000	TOOTHED WASHER	1	
9	011208025	HEX HEAD BOLT	1	REPLACES P/N 0016908025
9A	0040508000	TOOTHED WASHER	1	

MUFFLER ASSY.

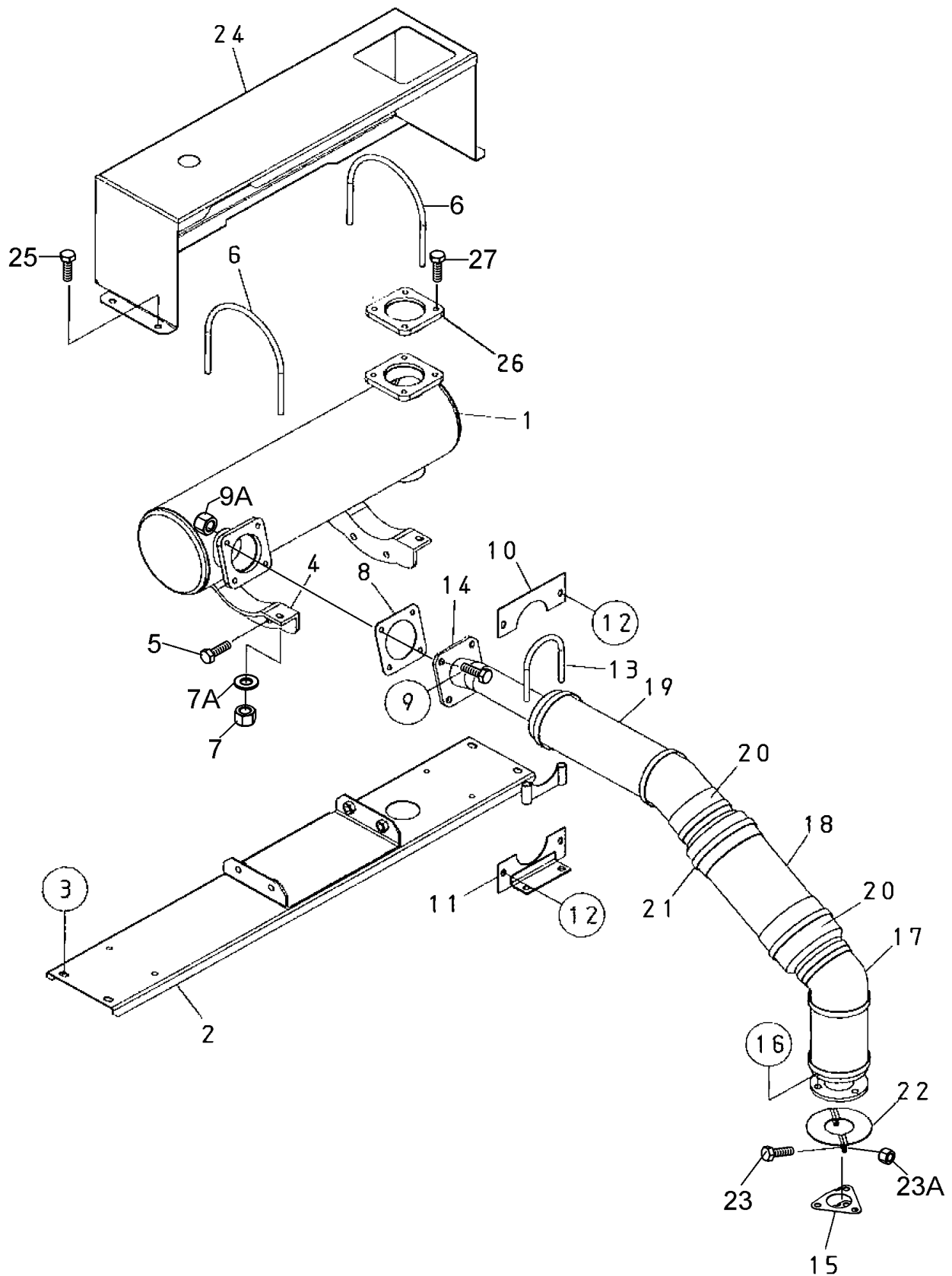

MUFFLER ASSY.

<u>NO.</u>	<u>PART NO.</u>	<u>PART NAME</u>	<u>QTY.</u>	<u>REMARKS</u>
1	8982353890	DOC.....	1.....	REPLACES P/N Y0602330111
2	M1331400403	DOC BRACKET	1	
3	011008020	HEX. HEAD BOLT.....	4.....	REPLACES P/N 0016908020
4	8982284330	DOC SUPPORT.....	2.....	REPLACES P/N Y0602330210
5	012010030	HEX. HEAD BOLT.....	4.....	REPLACES P/N 0017110030
6	8982103230	U-BOLT.....	2.....	REPLACES P/N Y0602322091
7	020108060	SELF-LOCKING NUT.....	4.....	REPLACES P/N 0037908000
7A	0401450080	WASHER, FLAT.....	4.....	REPLACES P/N 0041208000
8	8973731080	GASKET.....	1.....	REPLACES P/N Y0602320212
9	8980435280	HEX. HEAD BOLT.....	4.....	REPLACES P/N Y0602322090
9A	8971616070	HEX NUT.....	4.....	REPLACES P/N Y0602323007
10	M1331400204	COVER, EXHAUST PIPE	1	
11	M1331400304	BRACKET, EXHAUST PIPE	1	
12	011106015	HEX. HEAD BOLT.....	4.....	REPLACES P/N 0016906015
13	Y0602326066	U BOLT	1	
14	M1334000803	EXHAUST PIPE	1	
15	8973679180	GASKET.....	1.....	REPLACES P/N Y0602320211
16	0207108000	SELF-LOCKING NUT	3	
17	M1331400604	EXHAUST HEAT SHIELD (A)	1	
18	M1331400704	EXHAUST HEAT SHIELD (B)	1	
19	M1331400804	EXHAUST HEAT SHIELD (C)	1	
20	Y0272100370	HEAT SHIELD TAPE	2	
21	Y0602325051	METAL CABLE TIE	8	
22	M1334300404	HEAT SHIELD STOPPER	2	
23	0019206015	HEX. HEAD BOLT	2	
23A	0176060030	SELF-LOCKING NUT.....	2.....	REPLACES P/N 0207006000
24	M1331300004	DOC COVER	1	
25	011008020	HEX. HEAD BOLT.....	4.....	REPLACES P/N 0016908020
26	M1334300604	FLANGE.....	1.....	S/N 8730131 AND ABOVE
27	Y0016908020	HEX HEAD BOLT.....	4.....	S/N 8730131 AND ABOVE

FUEL TANK ASSY.

<u>NO.</u>	<u>PART NO.</u>	<u>PART NAME</u>	<u>QTY.</u>	<u>REMARKS</u>
1	M1364000202	FUEL TANK	1	
1-1	0605505070	FUEL TANK CAP	1	
1-2	0605501072	FUEL SENDER UNIT	1	
2	M1364200004	TANK BAND	2	
3	M1363200404	TANK BAND	2	
4	M9310500104	SUPPORTER SHEET	4	
5	011008020	HEX. HEAD BOLT	4	REPLACES P/N 0016908020
6	Y0207008000	SELF-LOCKING NUT	4	
7	8980682750	FUEL FEED PUMP	1	REPLACES P/N 0602023240
7A	8981731650	KIT, FEED PUMP, FILTER	1	
8	0191301150	VENT HOSE	1	
9	Y0605515340	HOSE BAND	12	
10	0191300950	SUCTION HOSE	1	
11	0191300550	SUCTION HOSE	1	
12	0191301100	RETURN HOSE	1	
13	Y0191300260	SUCTION HOSE	1	
14	0191300530	SUCTION HOSE	1	
15	M1484500204	FUEL FILTER BRACKET	1	
16	012210035	HEX. HEAD BOLT	4	REPLACES P/N 0017110035
17	0016910030	HEX. HEAD BOLT	2	
18	M1366700304	FUEL PUMP BRACKET	1	
19	011008020	HEX. HEAD BOLT	2	REPLACES P/N 0016908020
20	011606025	HEX. HEAD BOLT	2	REPLACES P/N 0016906025
21	8982369900	FUEL FILTER (MAIN)	1	REPLACES P/N 0602042428
21A	8982402800	ELEMENT, FUEL FILTER (MAIN)	1	
22	8982369910	FUEL FILTER (PRE.)	1	REPLACES P/N 0602042429
22A	8982402790	ELEMENT, FUEL FILTER (PRE)	1	
23	1096300850	PACKING	8	REPLACES P/N Y0602021700
24	1096751930	EYE BOLT	4	REPLACES P/N Y0602042624
25	8981263320	JOINT PIPE	4	REPLACES P/N Y0602042623
26	0222100700	RUBBER SEAL	5	

BATTERY CHARGER ASSY.

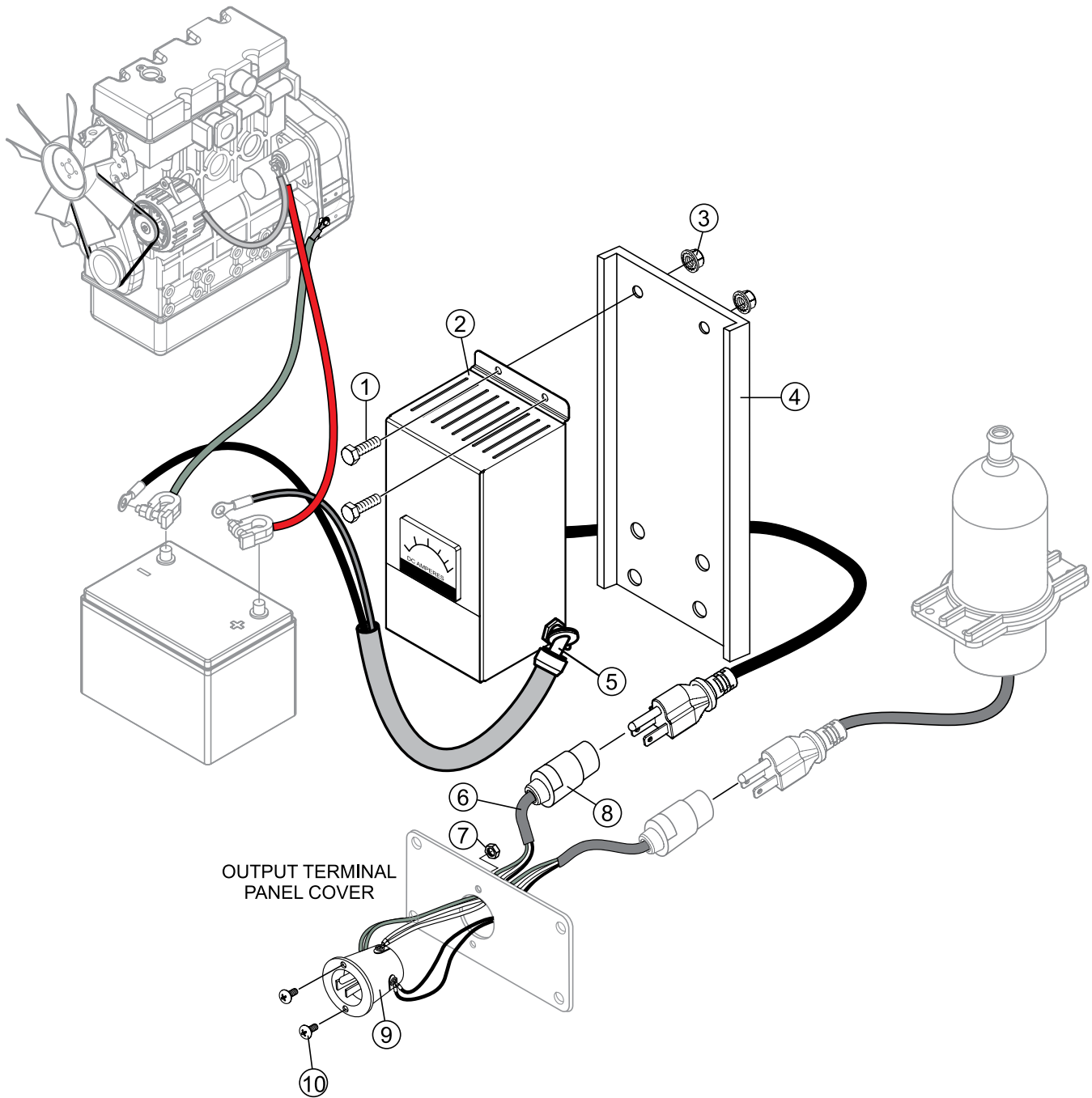

BATTERY CHARGER ASSY.

<u>NO.</u>	<u>PART NO.</u>	<u>PART NAME</u>	<u>QTY.</u>	<u>REMARKS</u>
1		SCREW, 10-24 X 1/2"	2.....	OBTAIN LOCALLY
2	LC125002	CHARGER, BATTERY 12V, 3A	1	
3		NUT, KEP (W/STAR WASHER)	2.....	OBTAIN LOCALLY
4	34530	BRACKET, BATTERY CHARGER	1	
5	EE6009	FITTING, CONDUIT, 90°, NON-METALLIC	1	
6	EE56557	CORD, CAROL 3/C 14 AWG	AR	1PC = 1FT.
7	OEMAA8	HEX NUT, 4MM	2	
8	HBL5369C	CONNECTOR, 20 AMP ,125V	1	
9	HBL5278C	INLET FLANGE, NEMA 15A 125V	1	
10	7538070	SCREW, PHILLIPS HD.	2	

JACKET WATER HEATER ASSY.

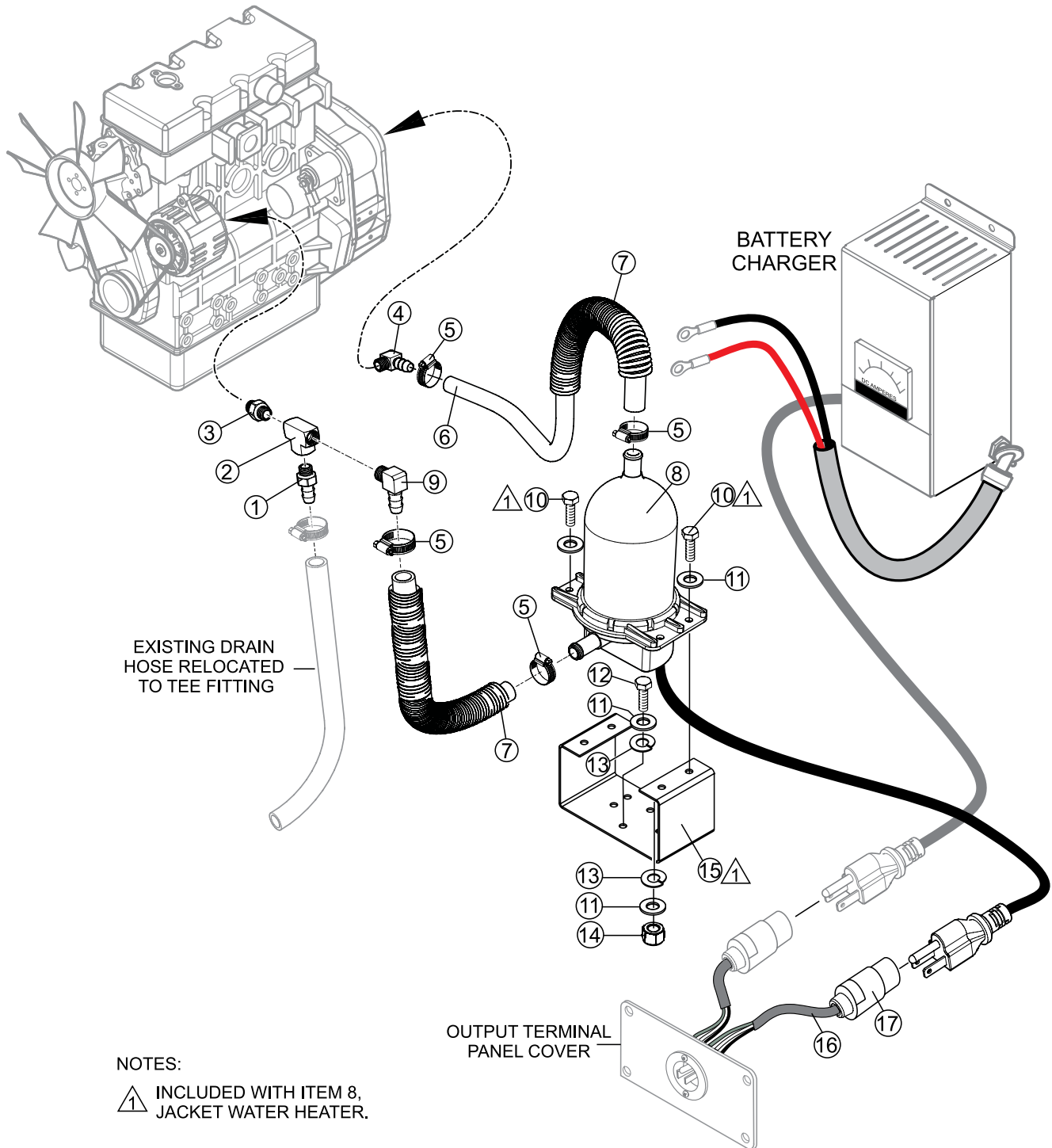

JACKET WATER HEATER ASSY.

<u>NO.</u>	<u>PART NO.</u>	<u>PART NAME</u>	<u>QTY.</u>	<u>REMARKS</u>
1		1/4" MP X 5/16 HB NIPPLE	1.....	OBTAIN LOCALLY
2		1/4 X 1/4 1/4" FEMALE PIPE TEE	1.....	OBTAIN LOCALLY
3		1/4 X 1/4 MALE TO MALE PIPE NIPPLE	1.....	OBTAIN LOCALLY
4		3/8" MP X 5/8 HB 90° ELBOW.....	1.....	OBTAIN LOCALLY
5		HOSE CLAMP #10	4.....	OBTAIN LOCALLY
6		HEATER HOSE, 5/8" ID X 30" LONG.....	1.....	OBTAIN LOCALLY
7		SPLIT LOOM, 1 " X 20"	2.....	OBTAIN LOCALLY
8	EE10814	HEATER, 1000W, 120 VAC.....	1.....	INCLUDES ITEMS W/#
9		1/4" MP X 5/8" HB 90° ELBOW	1.....	OBTAIN LOCALLY
10#		BOLT, 1/4"-20 X 1"	4.....	OBTAIN LOCALLY
11		WASHER, FLAT 1".....	4.....	OBTAIN LOCALLY
12		BOLT, 1/4"-20 X 3/4"	6.....	OBTAIN LOCALLY
13		WASHER, LOCK 1/4"	6.....	OBTAIN LOCALLY
14		NUT, 1/4"	4.....	OBTAIN LOCALLY
15#	EE1266	BRACKET, HOT START	1	
16	EE56557	CORD, 3-CONDUCTOR, 14 AWG, 2 FT.	1	
17	HBL5369C	CONNECTOR, 20 AMP ,125V	1	

ENCLOSURE ASSY.

<u>NO.</u>	<u>PART NO.</u>	<u>PART NAME</u>	<u>QTY.</u>	<u>REMARKS</u>
1	M1414000602	BASE	1	
2	M1414800003	ENVIRONMENTAL TANK	1	
3	0016910030	HEX. HEAD BOLT	8	
4	0603306797	SQUARE HEAD PIPE PLUG 1-1/2"	1	
5	Y0603306793	SQUARE HEAD PIPE PLUG 1/2"	1	
6	M1424000702	FRONT FRAME	1	
6A	M1494101903	ACOUSTIC SHEET	1	
7	011008020	HEX. HEAD BOLT	6.....	REPLACES P/N 0016908020
8	M1424201004	COVER, FRONT FRAME	1	
8A	M1494102004	ACOUSTIC SHEET	1	
9	0019208020	HEX. HEAD BOLT	13	
10	M1311200604	RADIATOR BRACKET	1	
11	M1311200704	RADIATOR BRACKET	1	
12	M1311300503	FAN SHROUD	1	
13	M1311300603	FAN SHROUD	1	
14	011008020	HEX. HEAD BOLT	8.....	REPLACES P/N 0016908020
15	M1311300703	FAN GUARD	1	
16	M1311300803	FAN GUARD	1	
17	011008020	HEX. HEAD BOLT	11.....	REPLACES P/N 0016908020
18	M1434000203	CENTER FRAME	1	
19	M1434000303	CENTER FRAME	1	
20	0013616040	HEX. HEAD BOLT	6	
20A	0040016000	WASHER, LOCK	6	
20B	0041216000	WASHER, FLAT	6	
21	M1414800404	FUEL LEAK SWITCH BRACKET	1	
22	011008020	HEX. HEAD BOLT	2.....	REPLACES P/N 0016908020
23	0605503062	FUEL LEAK DETECTED SWITCH	1	
24	Y0013616035	HEX. HEAD BOLT	4	
24A	0040016000	WASHER, LOCK	4	
24B	0041216000	WASHER, FLAT	4	
25	M1444000302	REAR FRAME	1	
25A	M1494301204	ACOUSTIC SHEET	2	
26	011008020	HEX. HEAD BOLT	4.....	REPLACES P/N 0016908020
27	M1444300603	REAR COVER	1	
28	M1444800403	DUCT, REAR COVER	1	
28A	M1494302503	ACOUSTIC SHEET	1	
29	176060030	SELF-LOCKING NUT	12.....	REPLACES P/N 0207006000
30	0019208020	HEX. HEAD BOLT	10	
31	M1444200203	REAR DOOR	1	
32	M1445600204	WINDOW PLATE	1	
33	020106050	LOCK NUT	10.....	REPLACES P/N 0037906000
33A	952404470	WASHER, FLAT	10.....	REPLACES P/N 0041206000

ENCLOSURE ASSY. (CONTINUED)

ADD THE FOLLOWING DIGITS AFTER THE PART NUMBER WHEN ORDERING ANY PAINTED PANEL TO INDICATE COLOR OF UNIT:

- | | |
|-----------------|----------------------|
| 1-ORANGE | 6-CATERPILLAR YELLOW |
| 2-WHITE | 7-CATO GOLD |
| 3-SPECTRUM GREY | 8-RED |
| 4-SUNBELT GREEN | 9-DESERT TAN |

THE SERIAL NUMBER MAY BE REQUIRED.

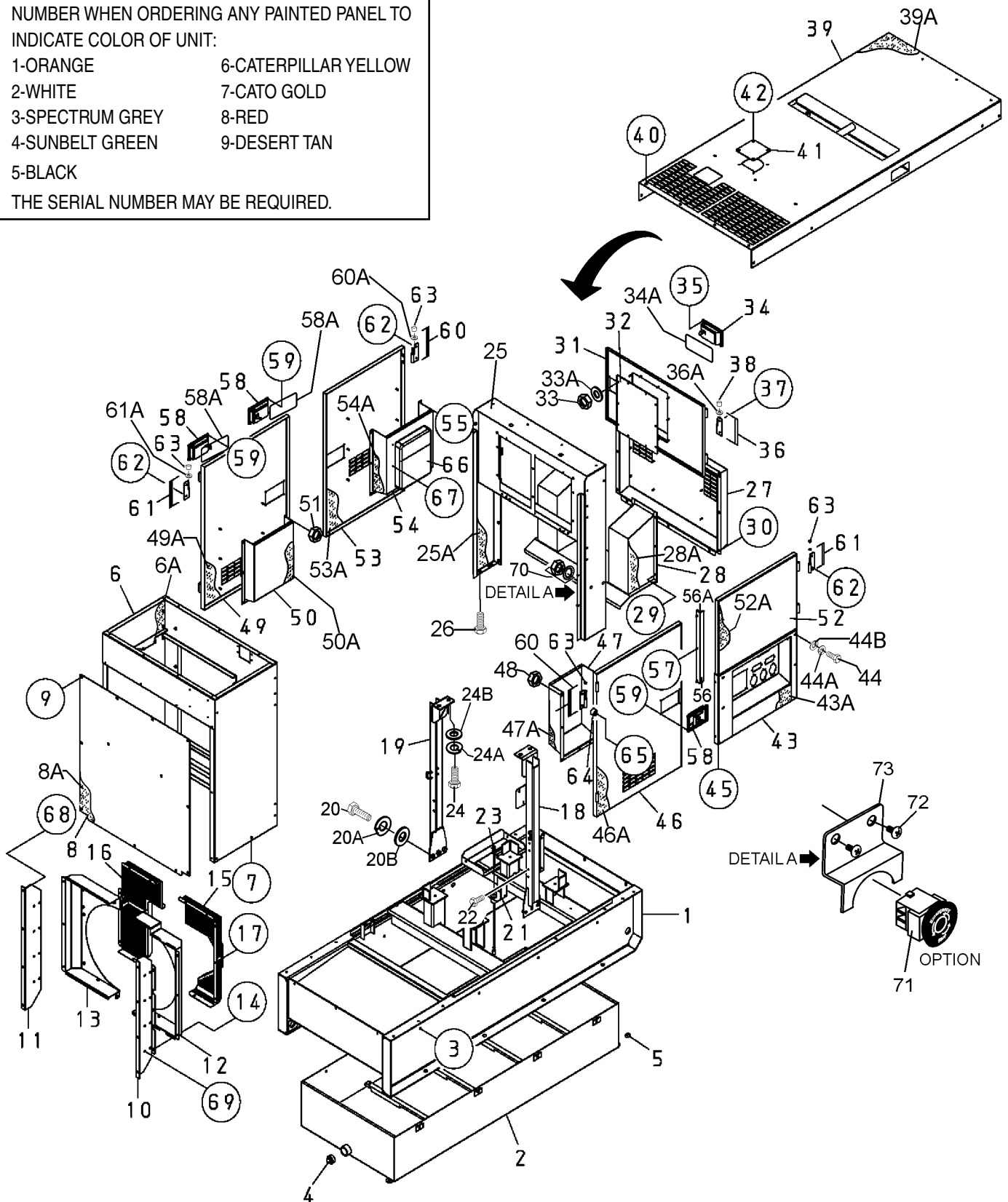

ENCLOSURE ASSY. (CONTINUED)

<u>NO.</u>	<u>PART NO.</u>	<u>PART NAME</u>	<u>QTY.</u>	<u>REMARKS</u>
34	Y0605012309	DOOR HANDLE ASSY.	1	
34A	C9312500004	SEAL RUBBER	1	
35	176060030	SELF-LOCKING NUT	4.....	REPLACES P/N 0207006000
36	M9110100204	HINGE	2	
36A	M9116100004	WASHER	2	
37	0019208020	HEX. HEAD BOLT	3	
38	845031504	BLIND PLUG.....	2.....	REPLACES P/N M9310000004
39	M1464000202	ROOF PANEL	1	
39A	M1494500803	ACOUSTIC SHEET	1	
40	0019208020	HEX. HEAD BOLT	19	
41	M3310600004	COVER	1	
42	0019208020	HEX. HEAD BOLT	4	
43	M1454200702	SPLASHER PANEL	1	
43A	M1494401304	ACOUSTIC SHEET	1	
44	0019108055	HEX. HEAD BOLT	4	
44A	0042308000	WASHER, LOCK	4	
44B	031108160	WASHER, FLAT	4.....	REPLACES P/N 0042408000
45	011008020	HEX. HEAD BOLT.....	2.....	REPLACES P/N 0016908020
46	M1454001003	SIDE DOOR	1	
46A	M1494401404	ACOUSTIC SHEET	1	
47	M1454300404	DUCT	1	
47A	M1494401904	ACOUSTIC SHEET	1	
48	176060030	SELF-LOCKING NUT	7.....	REPLACES P/N 0207006000
49	M1454001103	SIDE DOOR	1	
49A	M1494401504	ACOUSTIC SHEET	1	
50	M1454300604	DUCT	1	
50A	M1494402104	ACOUSTIC SHEET	1	
51	176060030	SELF-LOCKING NUT	7.....	REPLACES P/N 0207006000
52	M1454001203	SIDE DOOR	1	
52A	M1494401604	ACOUSTIC SHEET	1	
53	M1454001303	SIDE DOOR	1	
53A	M1494401703	ACOUSTIC SHEET	1	
54	M1454300703	DUCT	1	
54A	M1494402204	ACOUSTIC SHEET	1	

ENCLOSURE ASSY. (CONTINUED)

ADD THE FOLLOWING DIGITS AFTER THE PART NUMBER WHEN ORDERING ANY PAINTED PANEL TO INDICATE COLOR OF UNIT:

- | | |
|-----------------|----------------------|
| 1-ORANGE | 6-CATERPILLAR YELLOW |
| 2-WHITE | 7-CATO GOLD |
| 3-SPECTRUM GREY | 8-RED |
| 4-SUNBELT GREEN | 9-DESERT TAN |

THE SERIAL NUMBER MAY BE REQUIRED.

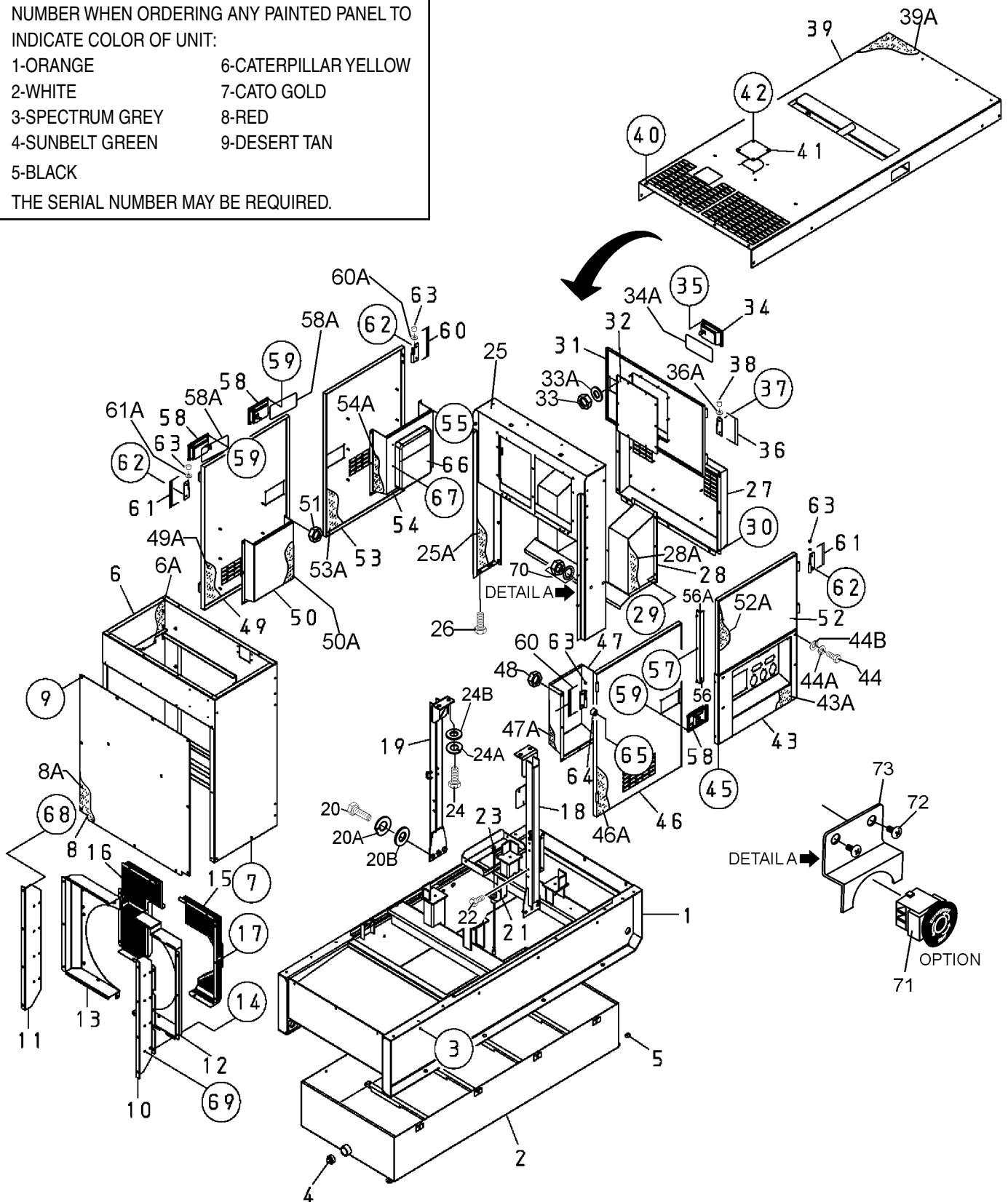

ENCLOSURE ASSY. (CONTINUED)

<u>NO.</u>	<u>PART NO.</u>	<u>PART NAME</u>	<u>QTY.</u>	<u>REMARKS</u>
55	176060030	SELF-LOCKING NUT	7.....	REPLACES P/N 0207006000
56	M1454700104	DOOR SUPPORTER	1	
56A	Y0229200480	RUBBER SEAL	1	
57	176060030	SELF-LOCKING NUT	3.....	REPLACES P/N 0207006000
58	Y0605012309	DOOR HANDLE ASSY.	3	
58A	C9312500004	SEAL RUBBER	3	
59	176060030	SELF-LOCKING NUT	12.....	REPLACES P/N 0207006000
60	M9110100204	HINGE	4	
60A	M9116100004	WASHER	4	
61	M9110100304	HINGE	4	
61A	M9116100004	WASHER	4	
62	0019208020	HEX. HEAD BOLT	9	
63	845031504	BLIND PLUG.....	8.....	REPLACES P/N M9310000004
64	0601850097	DOOR STOPPER	8	
65	0027208025	MACHINE SCREW	8	
66	0600800320	MANUAL PAK	1	
67	27106016	MACHINE SCREW	4.....	REPLACES P/N 0021806015
68	011008020	HEX. HEAD BOLT	8.....	REPLACES P/N 0016908020
69	011008020	HEX HEAD BOLT	16.....	REPLACES P/N 0016908020
70		NUT, 10-24 (W/ STAR WASHER)	2.....	OBTAIN LOCALLY
71	EE55989	SWITCH, EMERGENCY STOP	1.....	OPTION
72		MACHINE SCREW 10-24X1/2	2.....	OBTAIN LOCALLY
73	EE1687	GUARD, EMERGENCY STOP	1	

RUBBER SEALS ASSY.

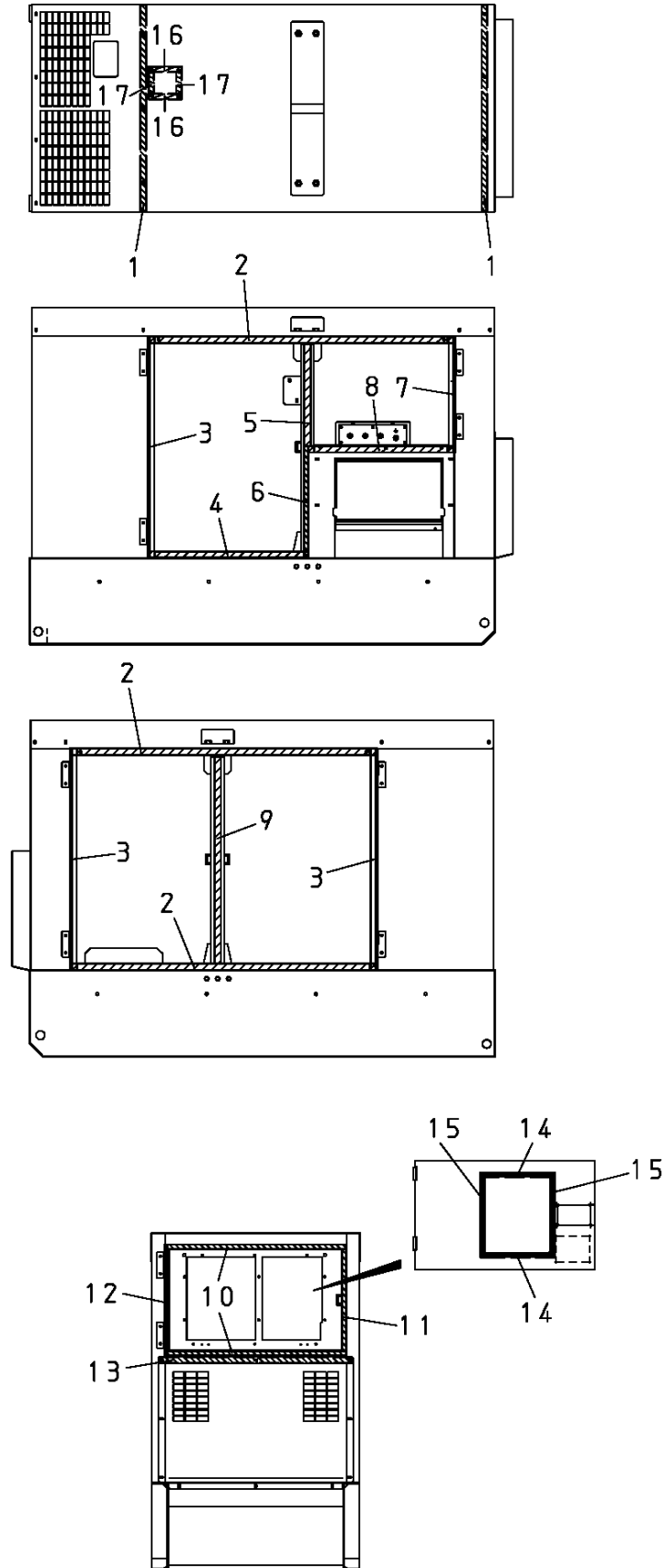

RUBBER SEALS ASSY.

<u>NO.</u>	<u>PART NO.</u>	<u>PART NAME</u>	<u>QTY.</u>	<u>REMARKS</u>
1	0229200950	RUBBER SEAL	2	
2	0228901390	RUBBER SEAL	3	
3	Y0229401020	RUBBER SEAL	3	
4	Y0228900705	RUBBER SEAL	1	
5	0228900475	RUBBER SEAL	1	
6	0228800515	RUBBER SEAL	1	
7	Y0229400535	RUBBER SEAL	1	
8	0228900660	RUBBER SEAL	1	
9	0228900960	RUBBER SEAL	1	
10	Y0228800820	RUBBER SEAL	2	
11	0228800470	RUBBER SEAL	1	
12	0228800510	RUBBER SEAL	1	
13	0229200880	RUBBER SEAL	1	
14	0228100340	RUBBER SEAL	2	
15	70NS2016	RUBBER SEAL.....	2.....	REPLACES P/N 0228100350
16	Y0229200145	RUBBER SEAL	2	
17	Y0229200100	RUBBER SEAL	2	

NAMEPLATE AND DECALS ASSY.

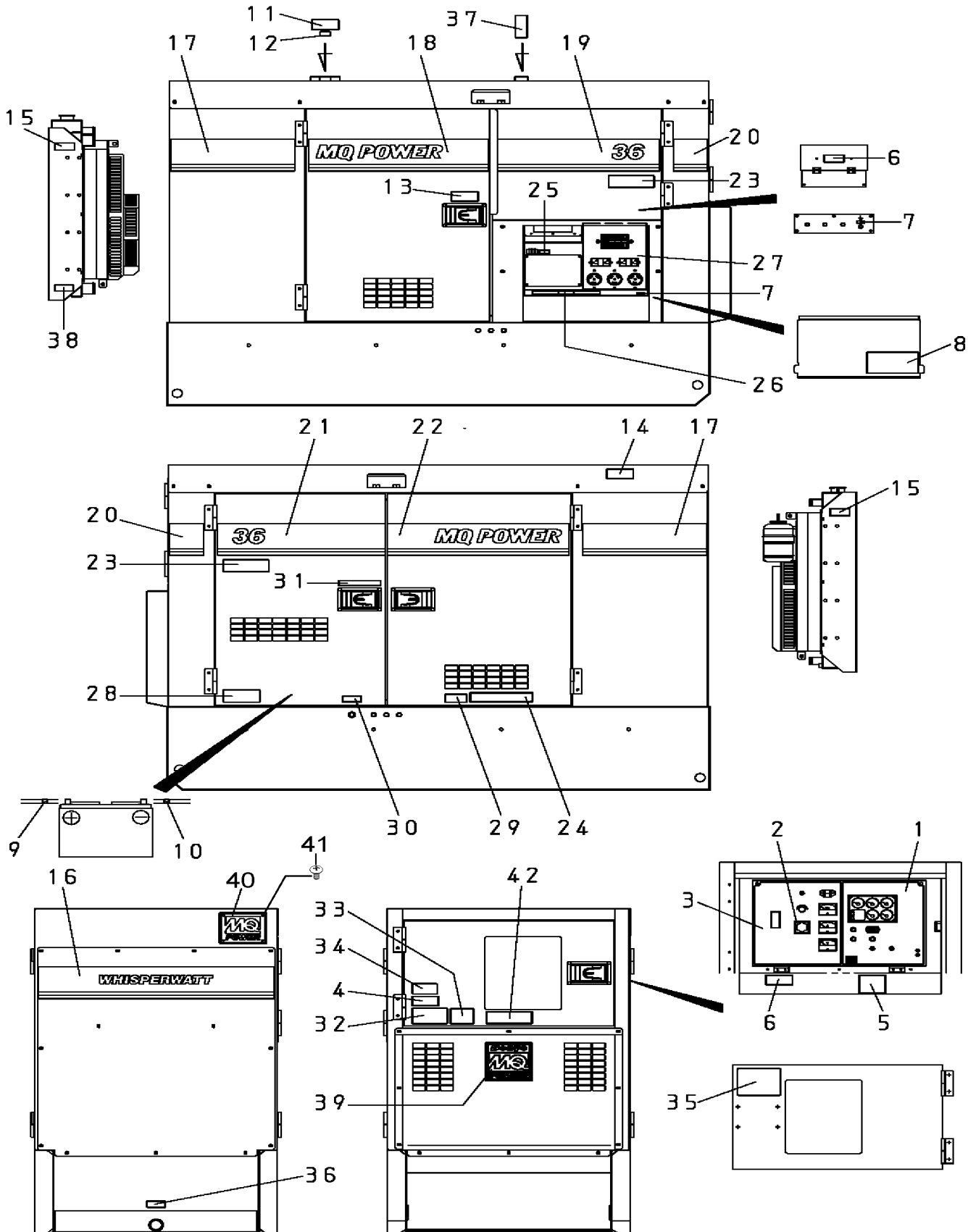

NAMEPLATE AND DECALS ASSY.

<u>NO.</u>	<u>PART NO.</u>	<u>PART NAME</u>	<u>QTY.</u>	<u>REMARKS</u>
1	M1551000903	DECAL: ENGINE OPERATING.....	1.....	M15100090
2	M9521000504	DECAL: AMMETER CHANGE-OVER SW.....	1.....	M92100050
3	M1551000803	DECAL: GENERATOR CONTROL	1.....	M15100080
4	M9520100704	DECAL: WARNING ARC FLASH.....	1.....	M92010070
5	M9520100304	DECAL: GENERAL CAUTIONS.....	1.....	M92010030
6	M9520100004	DECAL: WARNING ELECTRICAL SHOCK	2.....	M92010000
7	M9520000004	DECAL: GROUNDING.....	2.....	M92000000
8	M9520100404	DECAL: DANGER HIGH VOLTAGE	1.....	M92010040
9	M9500300104	DECAL: +	1.....	M90030010
10	M9500300004	DECAL: -	1.....	M90030000
11	M9503100004	DECAL: WARNING RADIATOR CAP.....	1.....	M90310000
12	M9500100004	DECAL: WATER.....	1.....	M90010000
13	M9510100004	DECAL: CAUTION HIGH TEMP.....	1.....	M91010000
14	M9503200004	DECAL: WARNING EXHAUST GAS.....	1.....	M90320000
15	M9503000004	DECAL: WARNING ROTATING PART	2.....	M90300000
16	M1561101103	STRIPE	1	
17	M1561101203	STRIPE	2	
18	M1561101303	STRIPE	1	
19	M1561102203	STRIPE	1	
20	M1561101504	STRIPE	2	
21	M1561102303	STRIPE	1	
22	M1561101703	STRIPE	1	
23	M9520100603	DECAL: CAUTION AUTO START	2.....	M92010060
24	M9503000103	DECAL: DAILY CHECK WATER AND OIL.....	1.....	M90300010
25	M9520000504	DECAL: START CONTACT	1.....	M92000050
26	M9520100503	DECAL: WARNING.....	1.....	M92010050
27	M1550002203	DECAL: AUXILIARY OUTPUTS	1.....	M15000220
28	M9510100403	DECAL: CAUTION BATTERY CONNECT	1.....	M91010040
29	M9501500004	DECAL: DIESEL FUEL	1.....	M90150000
30	M9500000004	DECAL: OIL DRAIN	1.....	M90000000
31	M9510000104	DECAL: DOCUMENT BOX LOCATED	1.....	M91000010
32	M9511100004	DECAL: ENVIRONMENTAL WARNING.....	1.....	M91110000
33	M9503200104	DECAL: DANGER EX. GAS (INDOOR).....	1.....	M90320010
34	920214100	DECAL: WARNING START FIRES	1.....	REPLACES P/N M9504200004 M90420000
35	M2550002303	OPERATING PRECAUTIONS	1.....	M25000230
36	M9510000004	DECAL: FLUID DRAIN.....	1.....	M91000000
37	M1550001504	CAUTION: LIFTING CAPACITY	1.....	M15000150
38	M9500100304	INTER-COOLER DRAIN.....	1.....	M90010030
39	M9511200204	STICKER: MQ.....	1.....	M91120020
40	0600500092	EMBLEM	1	
41	0021106015	MACHINE SCREW	4	
42	M9511200103	TIER 4F.....	1.....	M91120010

TERMS AND CONDITIONS OF SALE — PARTS

PAYMENT TERMS

Terms of payment for parts are net 30 days.

FREIGHT POLICY

All parts orders will be shipped collect or prepaid with the charges added to the invoice. All shipments are F.O.B. point of origin. Multiquip's responsibility ceases when a signed manifest has been obtained from the carrier, and any claim for shortage or damage must be settled between the consignee and the carrier.

MINIMUM ORDER

The minimum charge for orders from Multiquip is \$15.00 net. Customers will be asked for instructions regarding handling of orders not meeting this requirement.

RETURNED GOODS POLICY

Return shipments will be accepted and credit will be allowed, subject to the following provisions:

1. A Returned Material Authorization must be approved by Multiquip prior to shipment.
2. To obtain a Return Material Authorization, a list must be provided to Multiquip Parts Sales that defines item numbers, quantities, and descriptions of the items to be returned.
 - a. The parts numbers and descriptions must match the current parts price list.
 - b. The list must be typed or computer generated.
 - c. The list must state the reason(s) for the return.
 - d. The list must reference the sales order(s) or invoice(s) under which the items were originally purchased.
 - e. The list must include the name and phone number of the person requesting the RMA.
3. A copy of the Return Material Authorization must accompany the return shipment.
4. Freight is at the sender's expense. All parts must be returned freight prepaid to Multiquip's designated receiving point.

5. Parts must be in new and resalable condition, in the original Multiquip package (if any), and with Multiquip part numbers clearly marked.
6. The following items are not returnable:
 - a. Obsolete parts. (If an item is in the price book and shows as being replaced by another item, it is obsolete.)
 - b. Any parts with a limited shelf life (such as gaskets, seals, "O" rings, and other rubber parts) that were purchased more than six months prior to the return date.
 - c. Any line item with an extended dealer net price of less than \$5.00.
 - d. Special order items.
 - e. Electrical components.
 - f. Paint, chemicals, and lubricants.
 - g. Decals and paper products.
 - h. Items purchased in kits.
7. The sender will be notified of any material received that is not acceptable.
8. Such material will be held for five working days from notification, pending instructions. If a reply is not received within five days, the material will be returned to the sender at his expense.
9. Credit on returned parts will be issued at dealer net price at time of the original purchase, less a 15% restocking charge.
10. In cases where an item is accepted, for which the original purchase document can not be determined, the price will be based on the list price that was effective twelve months prior to the RMA date.
11. Credit issued will be applied to future purchases only.

PRICING AND REBATES

Prices are subject to change without prior notice. Price changes are effective on a specific date and all orders received on or after that date will be billed at the revised price. Rebates for price declines and added charges for price increases will not be made for stock on hand at the time of any price change.

Multiquip reserves the right to quote and sell direct to Government agencies, and to Original Equipment Manufacturer accounts who use our products as integral parts of their own products.

SPECIAL EXPEDITING SERVICE

A \$35.00 surcharge will be added to the invoice for special handling including bus shipments, insured parcel post or in cases where Multiquip must personally deliver the parts to the carrier.

LIMITATIONS OF SELLER'S LIABILITY

Multiquip shall not be liable hereunder for damages in excess of the purchase price of the item with respect to which damages are claimed, and in no event shall Multiquip be liable for loss of profit or good will or for any other special, consequential or incidental damages.

LIMITATION OF WARRANTIES

No warranties, express or implied, are made in connection with the sale of parts or trade accessories nor as to any engine not manufactured by Multiquip. Such warranties made in connection with the sale of new, complete units are made exclusively by a statement of warranty packaged with such units, and Multiquip neither assumes nor authorizes any person to assume for it any other obligation or liability whatever in connection with the sale of its products. Apart from such written statement of warranty, there are no warranties, express, implied or statutory, which extend beyond the description of the products on the face hereof.

Effective: February 22, 2006

PARTS MANUAL

HERE'S HOW TO GET HELP

PLEASE HAVE THE MODEL AND SERIAL
NUMBER ON-HAND WHEN CALLING

UNITED STATES

Multiquip Corporate Office

18910 Wilmington Ave.
Carson, CA 90746
Contact: mq@multiquip.com

Tel. (800) 421-1244
Fax (310) 537-3927

MQ Parts Department

800-427-1244
310-537-3700

Fax: 800-672-7877

Service Department

800-421-1244
310-537-3700

Warranty Department

800-421-1244
310-537-3700

Fax: 310-943-2249

Technical Assistance

800-478-1244

Fax: 310-943-2238

CANADA

Multiquip

4110 Industriel Boul.
Laval, Quebec, Canada H7L 6V3
Contact: infocanda@multiquip.com

Tel: (450) 625-2244
Tel: (877) 963-4411
Fax: (450) 625-8664

UNITED KINGDOM

Multiquip (UK) Limited Head Office

Unit 2, Northpoint Industrial Estate,
Globe Lane,
Dukinfield, Cheshire SK16 4UJ
Contact: sales@multiquip.co.uk

Tel: 0161 339 2223
Fax: 0161 339 3226

© COPYRIGHT 2017, MULTQUIP INC.

Multiquip Inc, the MQ logo and the MQ Power logo are registered trademarks of Multiquip Inc. and may not be used, reproduced, or altered without written permission. All other trademarks are the property of their respective owners and used with permission.

This manual MUST accompany the equipment at all times. This manual is considered a permanent part of the equipment and should remain with the unit if resold.

The information and specifications included in this publication were in effect at the time of approval for printing. Illustrations, descriptions, references and technical data contained in this manual are for guidance only and may not be considered as binding. Multiquip Inc. reserves the right to discontinue or change specifications, design or the information published in this publication at any time without notice and without incurring any obligations.

Your Local Dealer is:

Manufactured for
MQ Power Inc.
by
DENYO CO., LTD, JAPAN

