

WSM

**WORKSHOP MANUAL
DIESEL GENERATOR**

**GL6000, GL7000,
GL9000, GL11000**

Kubota

TO THE READER

This Workshop Manual has been prepared to provide servicing personnel with information on the mechanism, service and maintenance of KUBOTA Generator GL Series. It is divided into three parts, "General", "Mechanism" and "Servicing".

■ **General**

Information on the general precautions, check and maintenance and special tools.

■ **Mechanism**

Information on the construction and function are included. This part should be understood before proceeding with troubleshooting, disassembling and servicing.

■ **Servicing**

There are troubleshooting, servicing specification lists, checking and adjusting, disassembling and assembling, and servicing which cover procedures, precautions, factory specifications and allowable limits.

All information illustrations and specifications contained in this manual are based on the latest product information available at the time of publication.

The right is reserved to make changes in all information at any time without notice.

June 2004

© KUBOTA Corporation 2004

Record of Revisions

For pdf, use search function {Search word} to find all the revised locations.

Last digit of the Code No.	Issue month	Main Revised Point and Corrective Measures {Search word}	Reference Page
3	2015.04	GL9000 / GL11000 Generator changed.	



SAFETY FIRST

This symbol, the industry's "Safety Alert Symbol", is used throughout this manual and on labels on the machine itself to warn of the possibility of personal injury. Read these instructions carefully.

It is essential that you read the instructions and safety regulations before you attempt to repair or use this unit.



DANGER

: Indicates an imminently hazardous situation which, if not avoided, will result in death or serious injury.



WARNING

: Indicates a potentially hazardous situation which, if not avoided, could result in death or serious injury.



CAUTION

: Indicates a potentially hazardous situation which, if not avoided, may result in minor or moderate injury.



IMPORTANT

: Indicates that equipment or property damage could result if instructions are not followed.



NOTE

: Gives helpful information.

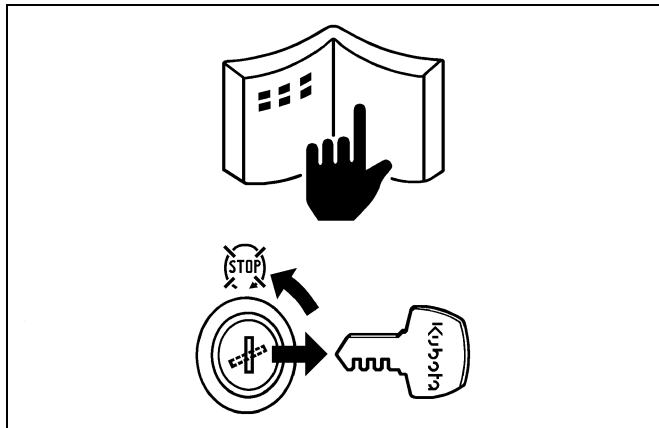

BEFORE SERVICING AND REPAIRING

- Read all instructions and safety instructions in this manual and on your generator safety decals.
- Clean the work area and generator.
- Park the generator on a firm and level ground.
- Allow the engine to cool before proceeding.
- Stop the engine, and remove the key.
- Disconnect the battery negative cable.



SAFETY STARTING

- Do not start the engine by shorting across starter terminals or bypassing the safety start switch.
- Unauthorized modifications to the engine may impair the function and / or safety and affect engine life.

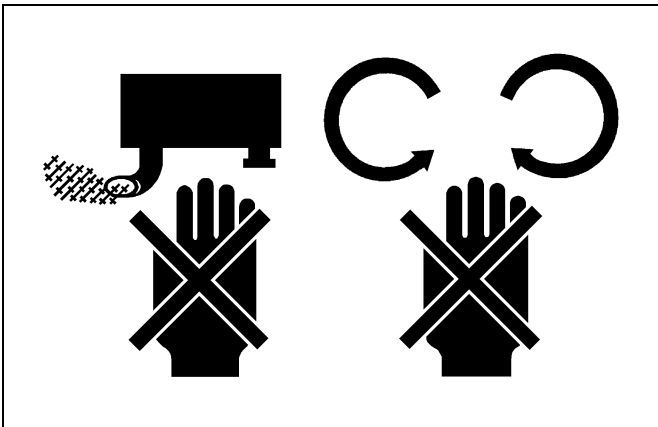

SAFETY WORKING

- Do not work on the generator while under the influence of alcohol, medication, or other substances or while fatigued.
- Wear close fitting clothing and safety equipment appropriate to the job.
- Use tools appropriate to the work. Makeshift tools, parts, and procedures are not recommended.
- When servicing is performed together by two or more persons, take care to perform all work safely.
- Do not touch the rotating or hot parts while the engine is running.
- Never remove the radiator cap while the engine is running, or immediately after stopping. Otherwise, hot water will spout out from radiator. Only remove radiator cap when cool enough to touch with bare hands. Slowly loosen the cap to first stop to relieve pressure before removing completely.
- Escaping fluid (fuel or hydraulic oil) under pressure can penetrate the skin causing serious injury. Relieve pressure before disconnecting hydraulic or fuel lines. Tighten all connections before applying pressure.
- Wear a suitable hearing protective device such as earmuffs or earplugs to protect against objectionable or uncomfortable loud noises.

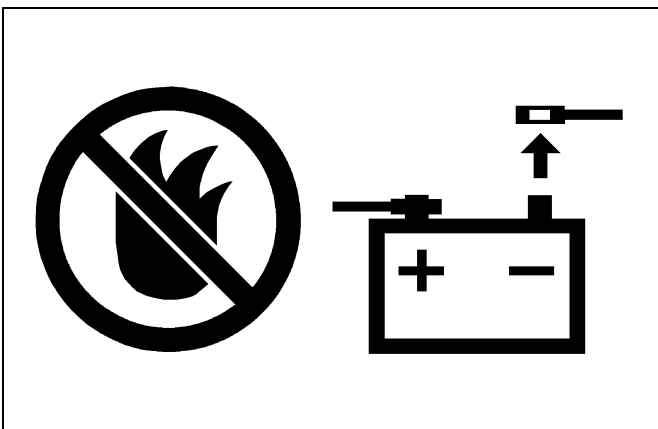
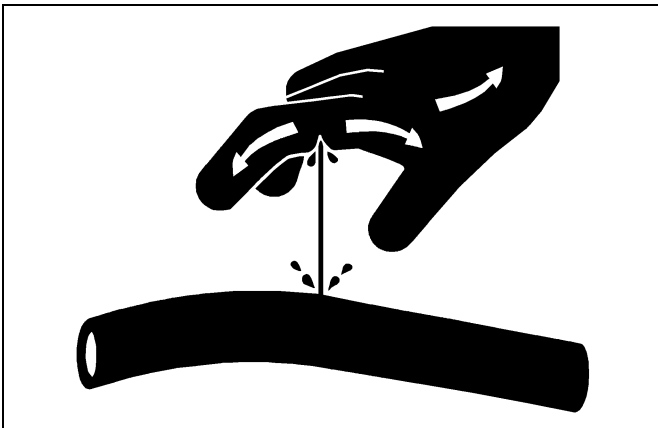

AVOID FIRES

- Fuel is extremely flammable and explosive under certain conditions. Do not smoke or allow flames or sparks in your working area.
- To avoid sparks from an accidental short circuit, always disconnect the battery negative cable first and connect it last.
- Battery gas can explode. Keep sparks and open flame away from the top of battery, especially when charging the battery.
- Make sure that no fuel has been spilled on the engine.

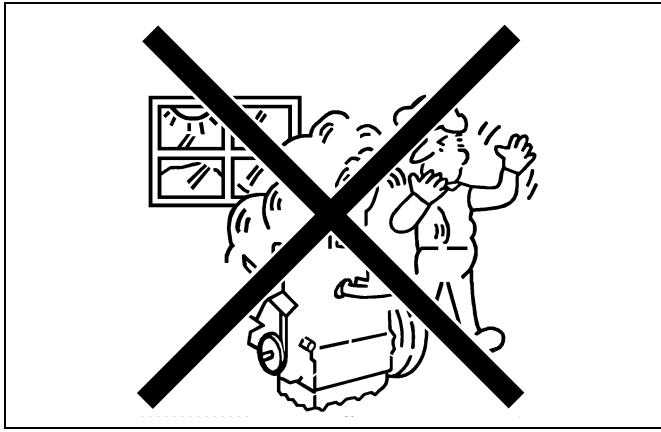

VENTILATE WORK AREA

- If the engine must be running to do some work, make sure the area is well ventilated. Never run the engine in a closed area. The exhaust gas contains poisonous carbon monoxide.

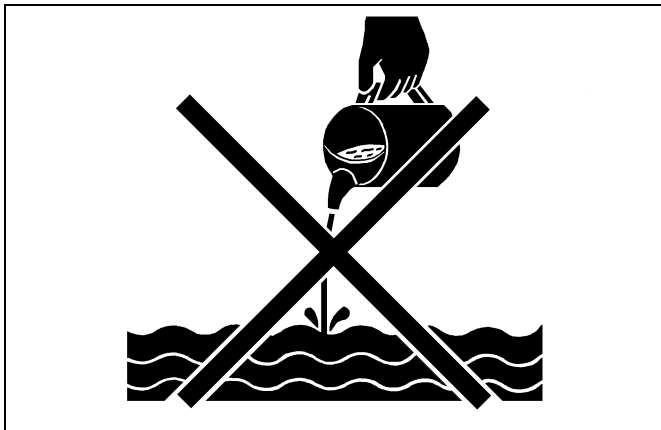

DISPOSE OF FLUIDS PROPERLY

- Do not pour fluids into the ground, down a drain, or into a stream, pond, or lake. Observe relevant environmental protection regulations when disposing of oil, fuel, coolant, electrolyte and other harmful waste.

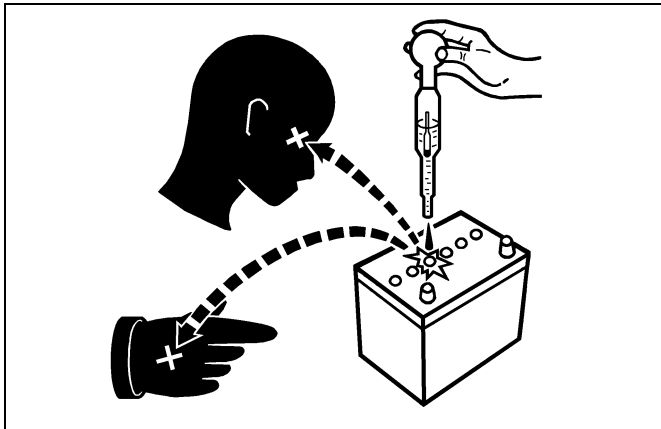

PREVENT ACID BURNS

- Sulfuric acid in battery electrolyte is poisonous. It is strong enough to burn skin, clothing and cause blindness if splashed into eyes. Keep electrolyte away from eyes, hands and clothing. If you spill electrolyte on yourself, flush with water, and get medical attention immediately.

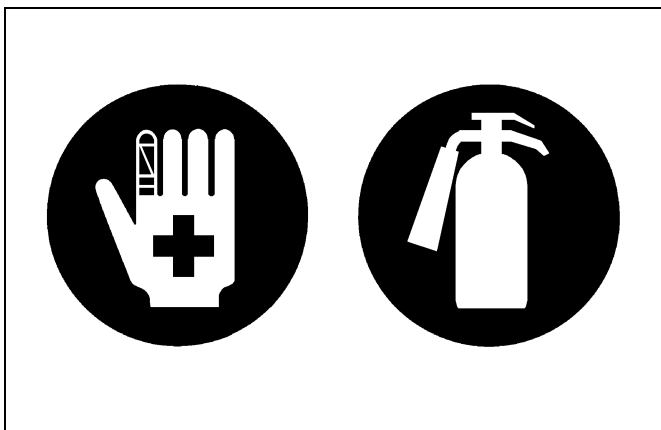

PREPARE FOR EMERGENCIES

- Keep a first aid kit and fire extinguisher handy at all times.
- Keep emergency numbers for doctors, ambulance service, hospital and fire department near your telephone.

SAFETY DECALS

The following safety decals are installed on the generator.
 If a decal becomes damaged, illegible or is not on the generator, replace it. The decal part number is listed in the parts list.
[Receptacle Type]

Part No. G3907-88311

⚠ DANGER

TO AVOID SERIOUS INJURY OR DEATH:

- HAZARDOUS VOLTAGE WILL SHOCK, BURN OR CAUSE DEATH.
- CONNECT OR DISCONNECT THE AC RECEPTACLES OR TERMINALS ONLY WHEN THE ENGINE IS STOPPED.
- DO NOT OPERATE THE MACHINE WITH THIS COVER REMOVED OR OPEN.

TO AVOID SERIOUS INJURY OR DEATH:

- DO NOT CONNECT THIS GENERATOR TO ANY BUILDING'S ELECTRICAL SYSTEM UNLESS AN ISOLATION SWITCH HAS BEEN INSTALLED BY A LICENSED ELECTRICIAN.
- REFER TO THE OPERATOR'S MANUAL FOR DETAILS.

G3907-88311

Part No. G3907-88301

⚠ CAUTION

TO AVOID PERSONAL INJURY:

- MAY RESULT IF FINGERS OR CLOTHING ARE CAUGHT IN ROTATING PARTS.
- DO NOT OPERATE THE MACHINE WITH THE SIDE COVERS OR ACCESS DOORS REMOVED OR OPEN.

G3907-88301

Part No. G3907-88331

IMPORTANT

STOP LEVER

STOP

IF THE ENGINE DOES NOT STOP AFTER TURNING THE KEY SWITCH TO "OFF" POSITION, TURN THE ENGINE STOP LEVER TO ARROW DIRECTION.

DO NOT REMOVE OR DISCONNECT THE BATTERY DURING OPERATION. OTHERWISE THE ENGINE CANNOT BE STOPPED WITH THE KEY SWITCH.

G3907-88331

Part No. 6C040-55591

⚠ DANGER EXPLOSIVE GASES

CAUSE SEVERE BURNS AND/OR DEATH. ALWAYS USE PROPER HANDLING PROCEDURES. KEEP VENTS TIGHT AND LEVEL.

POISON CAUSES SEVERE BURNS

CAUSE SEVERE BURNS AND/OR DEATH. ALWAYS USE PROPER HANDLING PROCEDURES. KEEP OUT OF REACH OF CHILDREN.

Part No. 18901-50902

Diesel fuel No.2

FLAMMABLE

18901-50902

Part No. G3102-50902 (USA model)

ULTRA LOW SULFUR DIESEL FUEL ONLY

Part No. G3102-88441

FUEL TANK CAPACITY
28L (7.4 U.S. gal)

⚠ WARNING

DO NOT REFUEL WHEN ENGINE IS RUNNING OR HOT. WHEN REFUELING, KEEP ALL FLAMES, SPARKS AND CIGARETTES AWAY FROM GENERATOR. DO NOT OVERFILL FUEL SYSTEM. IF ANY FUEL OVERFLOWS, WIPE IT UP COMPLETELY BEFORE STARTING OPERATION.

Part No. G3102-88391 (USA model)

⚠ WARNING

Operation of This Equipment May Create Sparks That Can Start Fires Around Dry Vegetation. A Spark Arrestor May be Required. The Operator Should Contact Local Fire Agencies For Laws or Regulations Relating to Fire Prevention Requirements.

Part No. G3102-88381 (USA model)

⚠ DANGER

Using a generator indoors CAN KILL YOU IN MINUTES. Generators exhaust carbon monoxide. This is a gas that you cannot see or smell!

NEVER use inside a home or garage, EVEN IF doors and windows are open. Only use OUTSIDE and far away from windows, doors, and vents.

Avoid other generator hazards. READ MANUAL BEFORE USE.

G3102-88381

Part No. G3907-88241

⚠ DANGER

TO AVOID SERIOUS INJURY OR DEATH:

- DO NOT OPERATE OR IDLE IN NONVENTILATED AREAS. CARBON MONOXIDE GAS IS COLORLESS, ODORLESS AND DEADLY.
- DO NOT OPERATE IN WET OR DAMP CONDITIONS.

⚠ CAUTION

TO AVOID PERSONAL INJURY OR EQUIPMENT DAMAGE BEFORE STARTING ENGINE

- TURN OFF GENERATOR CIRCUIT BREAKER.
- TURN OFF ALL SWITCHES ON ELECTRICAL LOAD.
- MAKE CERTAIN LOAD CONNECTIONS AND POWER CABLES ARE IN GOOD CONDITION.

G3907-88241

Part No. G3907-88231

OPERATING INSTRUCTIONS

Before operating the engine, please read the Operator's Manual carefully to ensure safe operation.

- Check the engine oil level and add, if the level is low.
- Check the engine coolant level and add, if the level is low.
- Check the fuel level and add, if the level is low.
- Make sure the terminal cover and access door are closed.
- Turn off the electrical device connected to the Generator.
- Check the Circuit breaker and set to OFF position.
- For the details of other inspection items and notes on safe operation, Read the Operator's Manual.

Starting and operation

- Turn the key to GLOW until the indicator lamp goes off.
- Turn the key to START and the engine will start. After starting, release the key.
- Make sure the warning lamps are OFF.
- Operate the engine with no load for a few minutes.
- Turn ON Set the Circuit breaker.
- Turn ON the electrical device connected to the Generator.

Stopping the engine

- Turn OFF the electrical device connected to the Generator.
- Set the Circuit breaker to OFF.
- Operate the engine with no load for a few minutes.
- Turn the key to OFF.

G3907-88231

Part No. G3906-88311

⚠ CAUTION

TO AVOID PERSONAL INJURY

- WORK MUST BE CONDUCTED BY CERTIFIED PEOPLE.
- FIRST, STOP THE ENGINE AND REMOVE STARTER KEY.
- REMOVE THE NEGATIVE TERMINAL OF BATTERY AND CONDUCT THE WORK TO AVOID AUTOMATIC STARTING BY THE SYSTEM.

ADVICE OF INSPECTION AND CLEANING - TO PREVENT A TRACKING FAILURE. IN DUSTY CONDITIONS, FOREIGN MATTER CAN ACCUMULATE ACROSS THE TERMINAL BLOCK (2) OF THE GENERATOR. THEN, WHEN IT GETS WET, ELECTRIC ARCING CAN OCCUR BETWEEN MAIN TERMINALS AND IT CAUSES A SHORT CIRCUIT OF MAIN TERMINALS. TO PREVENT THE FAILURE, REMOVE THE REAR COVER (1), AND CHECK FOR THE DUST AND MOISTURE ON THE TERMINAL BLOCK REGULARLY. (CLEAN WITH APPROVED CLEANING AGENT OR MOISTURE DISPLACER.) IN CASE ANY DISCOLORATION AND DEFORMATION OF THE TERMINAL BLOCK, REPLACE WITH NEW TERMINAL BLOCK.

G3906-88311

3EJACAAC001A

[Terminal Type]

Part No. G3101-88312

⚠ DANGER

TO AVOID SERIOUS INJURY OR DEATH:

- HAZARDOUS VOLTAGE WILL SHOCK, BURN OR CAUSE DEATH.
- CONNECT OR DISCONNECT THE AC RECEPTACLES OR TERMINALS ONLY WHEN THE ENGINE IS STOPPED.
- DO NOT OPERATE THE MACHINE WITH THIS COVER REMOVED OR OPEN.
- BEFORE ATTEMPTING TO START, ENSURE THIS COVER IS FITTED CORRECTLY WITH LOCK BOLTS FASTENED.

TO AVOID SERIOUS INJURY OR DEATH:

- DO NOT CONNECT THIS GENERATOR TO ANY BUILDING'S ELECTRICAL SYSTEM UNLESS AN ISOLATION SWITCH HAS BEEN INSTALLED BY A LICENSED ELECTRICIAN.
- REFER TO THE OPERATOR'S MANUAL FOR DETAILS.

• IF THIS COVER IS OPENED AND THE KEY SWITCH IS TURNED TO START POSITION, THE ENGINE WILL NOT START.

• IF THIS COVER IS OPENED WHILE RUNNING, THE ENGINE WILL STOP.

Part No. G3907-88301

⚠ CAUTION

TO AVOID PERSONAL INJURY :

- MAY RESULT IN FINGERS OR CLOTHING ARE CAUGHT IN ROTATING PARTS.
- DO NOT OPERATE THE MACHINE WITH THE SIDE COVERS OR ACCESS DOORS REMOVED OR OPEN.

G3907-88301

Part No. G3907-88331

IMPORTANT

STOP LEVER



STOP

IF THE ENGINE DOES NOT STOP AFTER TURNING THE KEY SWITCH TO "OFF" POSITION, TURN THE ENGINE STOP LEVER TO ARROW DIRECTION.

DO NOT REMOVE OR DISCONNECT THE BATTERY DURING OPERATION. OTHERWISE THE ENGINE CANNOT BE STOPPED WITH THE KEY SWITCH.

G3907-88331

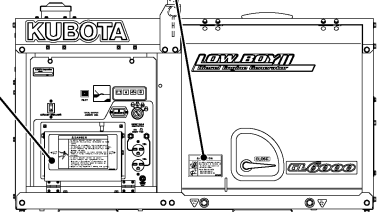

Part No. 18901-50902

Diesel fuel No.2

FLAMMABLE

18901-50902

Part No. G3102-50902 (USA model)

ULTRA LOW SULFUR DIESEL FUEL ONLY

Part No. G3102-88441

FUEL TANK CAPACITY
28L (7.4 U.S. gal)

⚠ WARNING

- DO NOT REFUEL WHEN ENGINE IS RUNNING OR HOT.
- WHEN REFUELING, KEEP ALL FLAMES, SPARKS AND CIGARETTES AWAY FROM GENERATOR.
- DO NOT OVERFILL FUEL SYSTEM. IF ANY FUEL OVERFLOWS, Wipe IT UP COMPLETELY BEFORE STARTING OPERATION.

Part No. 6C040-55591

⚠ DANGER EXPLOSIVE GASES

CAUTION: BATTERY VOLTAGE IS 24VDC. ALWAYS WEAR PROTECTIVE GLOVES AND EYE PROTECTION.

KEEP VENT CAPS TIGHT AND LEVEL.

POISON CAUSES SEVERE BURNS

CAUTION: ALWAYS WEAR PROTECTIVE GLOVES AND EYE PROTECTION.

KEEP OUT OF REACH OF CHILDREN.

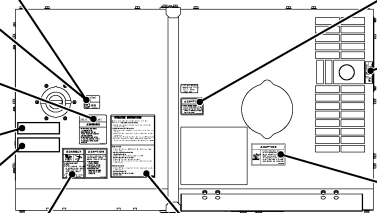

Part No. G3102-88391 (USA model)

⚠ WARNING

Operation of This Equipment May Create Sparks That Can Start Fires Around Dry Vegetation. A Spark Arrestor May be Required. The Operator Should Contact Local Fire Agencies For Laws or Regulations Relating to Fire Prevention Requirements.

Part No. 18620-88061

⚠ CAUTION

HOT EXHAUST

Part No. G3907-88321

⚠ CAUTION

TO AVOID PERSONAL INJURY :

- DO NOT REMOVE RADIATOR CAP WHILE COOLANT IS HOT.
- WHEN COOL, ROTATE CAP SLOWLY TO THE FIRST STOP TO ALLOW EXCESS PRESSURE TO ESCAPE.
- THEN REMOVE CAP COMPLETELY.

G3907-88321

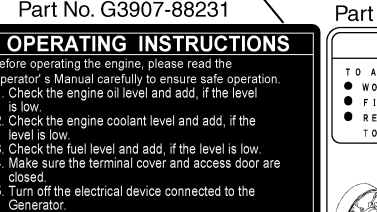

Part No. G3102-88381 (USA model)

⚠ DANGER

Using a generator indoors CAN KILL YOU IN MINUTES. Generator exhaust contains carbon monoxide. This is a poison you cannot see or smell.

NEVER use inside a home or garage. EVEN IF doors and windows are open.

Only use OUTSIDE and far away from windows, doors, and vents.

Avoid other generator hazards. READ MANUAL BEFORE USE. G3102-88381

Part No. G3907-88231

OPERATING INSTRUCTIONS

Before operating the engine, please read the Operator's Manual carefully to ensure safe operation.

- Check the engine oil level and add, if the level is low.
- Check the engine coolant level and add, if the level is low.
- Check the fuel level and add, if the level is low.
- Make sure the terminal cover and access door are closed.
- Turn off the electrical device connected to the Generator.
- Check the Circuit breaker and set to OFF position.
- For the details of other inspection items and notes on safe operation, Read the Operator's Manual.

Starting and operation

- Turn the key to GLOW until the indicator lamp goes off.
- Turn the key to START and the engine will start. After starting, release the key.
- Make sure the warning lamps are OFF.
- Operate the engine with no load for a few minutes.
- Turn ON Set the Circuit breaker.
- Turn ON the electrical device connected to the Generator.

Stopping the engine

- Turn OFF the electrical device connected to the Generator.
- Set the Circuit breaker to OFF.
- Operate the engine with no load for a few minutes.
- Turn the key to OFF.

G3907-88231

Part No. G3906-88311

⚠ CAUTION

TO AVOID PERSONAL INJURY

- WORK MUST BE CONDUCTED BY CERTIFIED PEOPLE.
- FIRST, STOP THE ENGINE AND REMOVE STARTER KEY.
- REMOVE THE NEGATIVE TERMINAL OF BATTERY AND CONDUCT THE WORK TO AVOID AUTOMATIC STARTING BY THE SYSTEM.

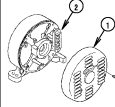

① REAR COVER
② TERMINAL BLOCK

ADVICE OF INSPECTION AND CLEANING - TO PREVENT A TRACKING FAILURE, IN DUSTY CONDITIONS, FOREIGN MATTER CAN ACCUMULATE ACROSS THE TERMINAL BLOCK (2) OF THE GENERATOR.

THEN, WHEN IT GETS WET, ELECTRIC ARCING CAN OCCUR BETWEEN MAIN TERMINALS AND IT CAUSES A SHORT CIRCUIT OF MAIN TERMINALS. TO PREVENT THE FAILURE, REMOVE THE REAR COVER (1), AND CHECK FOR THE DUST AND MOISTURE ON THE TERMINAL BLOCK REGULARLY. [CLEAN WITH APPROVED CLEANING AGENT OR MOISTURE DISPLACER.]

IN CASE ANY DISCOLORATION AND DEFORMATION OF THE TERMINAL BLOCK, REPLACE WITH NEW TERMINAL BLOCK. G3906-88311

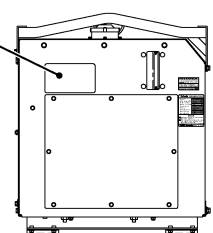

Part No. G3907-88241

⚠ DANGER



TO AVOID SERIOUS INJURY OR DEATH :

- DO NOT OPERATE OR IDLE IN NONVENTILATED AREAS. CARBON MONOXIDE GAS IS COLORLESS, ODORLESS AND DEADLY.
- DO NOT OPERATE IN WET OR DAMP CONDITIONS.

⚠ CAUTION

TO AVOID PERSONAL INJURY OR EQUIPMENT DAMAGE BEFORE STARTING ENGINE

- TURN OFF GENERATOR CIRCUIT BREAKER.
- TURN OFF ALL SWITCHES ON ELECTRICAL LOAD.
- MAKE CERTAIN LOAD CONNECTIONS AND POWER CABLES ARE IN GOOD CONDITION.

G3907-88241

3EJACAACP002A

5

KISC issued 05, 2015 A

SPECIFICATIONS

Model		GL6000-STD	GL6000-AUS
Generator	Frequency	50 Hz	
	Rated output	5.5 kW	
	Maximum output	6.0 kW	
	Rated voltage	220 V	240 V
	Rated current	25 A	22.9 A
	Phrase and wire	1 - 2	
	Number of poles	2	
	Power Factor	1	
	Insulation	Stator coil: B Rotor coil: F	
Engine	Design	Vertical, liquid cooled, 4 cycle, diesel	
	Model name	Z482-E2B-SEC-2	
	Rated output	6.9 kW	
	Speed	3000 min ⁻¹ (rpm)	
	Number of cylinder - Bore x Stroke	2 - ϕ 67 x 68 mm (2 - ϕ 2.52 x 2.68 in.)	
	Displacement	0.479 L (29.23 cu.in.)	
	Fuel tank capacity	28 L (7.4 U.S.gals)	
	Crankcase oil capacity	2.2 L (0.58 U.S.gals)	
	Starting system	Electric type 12 V / 0.8 kW	
	Battery	38B20R 12 V x 28 Ah / 5 Hr	
Continuous operating hours (at rated load)		12 hrs	
Net weight kg (lbs)		235 kg (518 lbs)	
Output	Receptacle	6-15R x 2	15A x 2
	Terminal	2P	-

* Conversion Formula : HP = 0.746 kW, PS = 0.7355 kW

W1028103

Model		GL7000-USA	GL7000-USA-TM	GL7000-STD
Generator	Frequency	60 Hz		
	Rated output	6.5 kW		
	Maximum output	7.0 kW		
	Rated voltage	120 / 240 V		110 / 220 V
	Rated current	54.2 / 27.1 A		59.1 / 29.5 A
	Phrase and wire	1 - 4		
	Number of poles	2		
	Power Factor	1		
	Insulation	Stator coil: B Rotor coil: F		
Engine	Design	Vertical, liquid cooled, 4 cycle, diesel		
	Model name	Z482-E2B-SEC-3		
	Rated output	8.1 kW		
	Speed	3600 min ⁻¹ (rpm)		
	Number of cylinder - Bore x Stroke	2 - ϕ 67 x 68 mm (2 - ϕ 2.52 x 2.68 in.)		
	Displacement	0.479 L (29.23 cu.in.)		
	Fuel tank capacity	28 L (7.4 U.S.gals)		
	Crankcase oil capacity	2.2 L (0.58 U.S.gals)		
	Starting system	Electric type 12 V / 0.8 kW		
	Battery	38B20R 12 V x 28 Ah / 5 Hr		
Continuous operating hours (at rated load)		10 hrs		
Net weight kg (lbs)		235 kg (518 lbs)		
Output	Receptacle	L14-30R L6-30R L5-30R 5-20RA (GFCI)	5-20RA (GFCI)	5-15R x 2
	Terminal	-		3P

* Conversion Formula : HP = 0.746 kW, PS = 0.7355 kW

W1030469

Model		GL9000-STD	GL9000-AUS
Generator	Frequency	50 Hz	
	Rated output	8.0 kW	
	Maximum output	8.8 kW	
	Rated voltage	220 V	240 V
	Rated current	36.4 A	33.3 A
	Phrase and wire	1 - 2	
	Number of poles	2	
	Power Factor	1	
	Insulation	Stator coil: B Rotor coil: F	
Engine	Design	Vertical, liquid cooled, 4 cycle, diesel	
	Model name	D722-E2B-SEC-2	
	Rated output	10.3 kW	
	Speed	3000 min ⁻¹ (rpm)	
	Number of cylinder - Bore x Stroke	3 - ϕ 67 x 68 mm (3 - ϕ 2.52 x 2.68 in.)	
	Displacement	0.719 L (48.89 cu.in.)	
	Fuel tank capacity	28 L (7.4 U.S.gals)	
	Crankcase oil capacity	3.4 L (0.90 U.S.gals)	
	Starting system	Electric type 12 V / 1.0 kW	
	Battery	55B24R 12 V x 36 Ah / 5 Hr	
Continuous operating hours (at rated load)		8.5 hrs	
Net weight kg (lbs)		280 kg (617 lbs)	
Output	Receptacle	6-15R x 2	15A x 3
	Terminal	2P	-

* Conversion Formula : HP = 0.746 kW, PS = 0.7355 kW

W1030823

Model		GL11000-USA	GL11000-USA-TM	GL11000-STD
Generator	Frequency	60 Hz		
	Rated output	10.0 kW		
	Maximum output	11.0 kW		
	Rated voltage	120 / 240 V		110 / 220 V
	Rated current	83.3 / 41.7 A		90.9 / 45.5 A
	Phrase and wire	1 - 3		
	Number of poles	2		
	Power Factor	1		
	Insulation	Stator coil: B Rotor coil: F		
Engine	Design	Vertical, liquid cooled, 4 cycle, diesel		
	Model name	D722-E2B-SEC-2		
	Rated output	12.2 kW		
	Speed	3600 min ⁻¹ (rpm)		
	Number of cylinder - Bore x Stroke	3 - ϕ 67 x 68 mm (3 - ϕ 2.52 x 2.68 in.)		
	Displacement	0.719 L (48.89 cu.in.)		
	Fuel tank capacity	28 L (7.4 U.S.gals)		
	Crankcase oil capacity	3.4 L (0.90 U.S.gals)		
	Starting system	Electric type 12 V / 1.0 kW		
	Battery	55B24R 12 V x 36 Ah / 5 Hr		
Continuous operating hours (at rated load)		7 hrs		
Net weight kg (lbs)		280 kg (617 lbs)		
Output	Receptacle	CS6369 (50 A) L6-30R L5-30R 5-20R (GFCI) x 2	5-20R (GFCI)	5-15R x 2

* Conversion Formula : HP = 0.746 kW, PS = 0.7355 kW

W1031698

DIMENSIONS

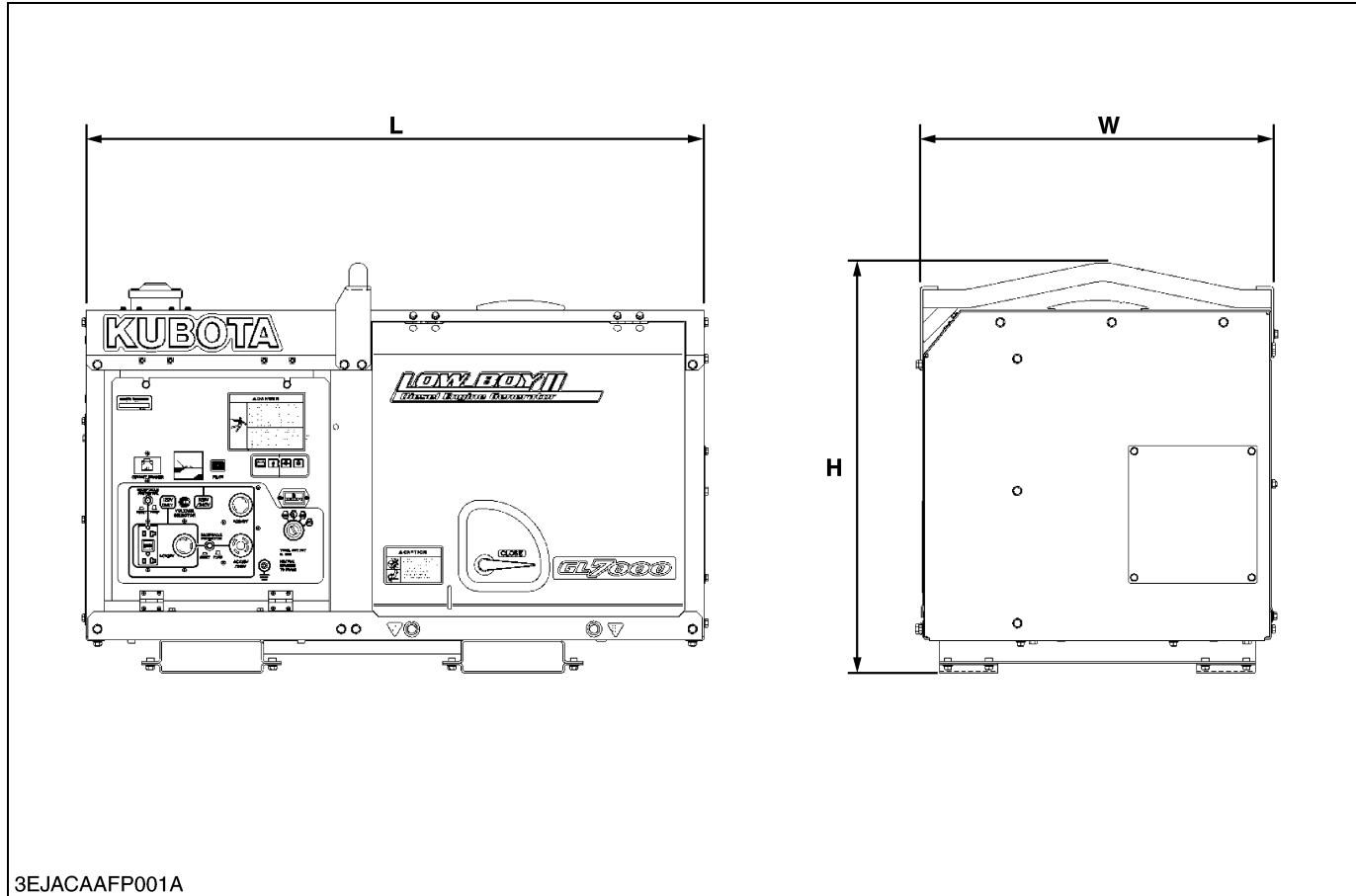

	GL6000-STD, GL6000-AUS, GL7000-STD, GL7000-USA, GL7000-USA-TM	GL9000-STD, GL9000-AUS, GL11000-STD, GL11000-USA, GL11000-USA-TM
L	1066 mm (42.0 in.)	1281 mm (50.4 in.)
W	618 mm (24.3 in.)	618 mm (24.3 in.)
H	698 mm (27.5 in.)	698 mm (27.5 in.)

W1038971

GENERAL

CONTENTS

1. IDENTIFICATION.....	G-1
[1] MODEL NAME AND ENGINE SERIAL NUMBER	G-1
[2] E4B ENGINE.....	G-2
[3] CYLINDER NUMBER	G-3
2. PRECAUTION.....	G-4
3. HANDLING PRECAUTIONS FOR ELECTRICAL PARTS AND WIRING..	G-5
[1] WIRING	G-5
[2] BATTERY.....	G-7
[3] FUSE.....	G-7
[4] CONNECTOR.....	G-7
[5] HANDLING OF CIRCUIT TESTER.....	G-8
4. LUBRICANTS, FUEL AND COOLANT	G-9
5. TIGHTENING TORQUES	G-11
[1] GENERAL USE SCREWS, BOLT AND NUTS.....	G-11
[2] STUD BOLTS.....	G-11
6. MAINTENANCE CHECK LIST.....	G-12
7. CHECK AND MAINTENANCE.....	G-14
[1] DAILY CHECK	G-14
[2] CHECK POINTS OF INITIAL 50 HOURS	G-15
[3] CHECK POINT OF EVERY 50 HOURS	G-16
[4] CHECK POINT OF EVERY 100 HOURS	G-16
[5] CHECK POINT OF EVERY 200 HOURS	G-18
[6] CHECK POINT OF EVERY 300 HOURS	G-19
[7] CHECK POINT OF EVERY 400 HOURS	G-19
[8] CHECK POINTS OF EVERY 500 HOURS	G-20
[9] CHECK POINT OF EVERY 800 HOURS	G-22
[10]CHECK POINT OF EVERY 1000 HOURS	G-23
[11]CHECK POINT OF EVERY 1500 HOURS	G-23
[12]CHECK POINT OF EVERY 1 YEAR.....	G-24
[13]CHECK POINT OF EVERY 2 YEARS	G-24
8. SPECIAL TOOLS.....	G-26

1. IDENTIFICATION

[1] MODEL NAME AND ENGINE SERIAL NUMBER

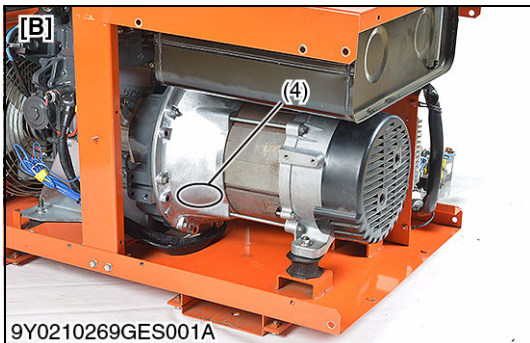
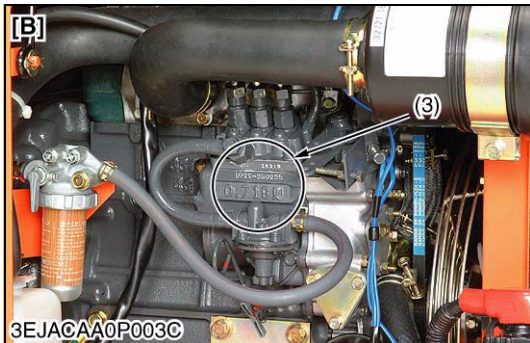
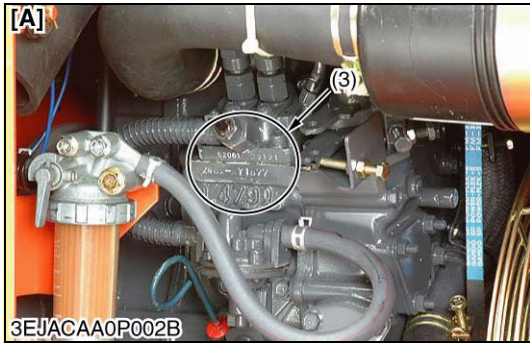

When contacting your local KUBOTA distributor, always specify the model name and serial numbers of both engine and generator.

The engine model and its serial number need to be identified before the engine can be serviced or parts replaced.

■ Engine Serial Number

The engine serial number is an identified number for the engine. It is marked after the engine model number.

It indicates month and year of manufacture as follows.

• Year of manufacture

Alphabet or Number	Year	Alphabet or Number	Year
4	2004	G	2016
5	2005	H	2017
6	2006	J	2018
7	2007	K	2019
8	2008	L	2020
9	2009	M	2021
A	2010	N	2022
B	2011	P	2023
C	2012	R	2024
D	2013	S	2025
E	2014	T	2026
F	2015	V	2027

- (1) Model Name
 - (2) Serial Number
 - (3) Engine Model Name and Serial Number
 - (4) Generator Model Name and Serial Number
- [A] GL6000, GL7000
[B] GL9000, GL11000

W1035676

• **Month of manufacture**

Month	Engine Serial Number	
	0001 ~ 9999	10000 ~
January	A0001 ~ A9999	B0001 ~
February	C0001 ~ C9999	D0001 ~
March	E0001 ~ E9999	F0001 ~
April	G0001 ~ G9999	H0001 ~
May	J0001 ~ J9999	K0001 ~
June	L0001 ~ L9999	M0001 ~
July	N0001 ~ N9999	P0001 ~
August	Q0001 ~ Q9999	R0001 ~
September	S0001 ~ S9999	T0001 ~
October	U0001 ~ U9999	V0001 ~
November	W0001 ~ W9999	X0001 ~
December	Y0001 ~ Y9999	Z0001 ~

e.g. D722-5A0001
 "5" indicates 2005 and "A" indicates January.
 So, 5A indicates that the engine was manufactured in January, 2005.

W1011076

[2] E4B ENGINE

[Example : Engine Model Name D902-E4B-XXXX]

The emission controls previously implemented in various countries to prevent air pollution will be stepped up as Non-Road Emission Standards continue to change. The timing or applicable date of the specific Non-Road Emission regulations depends on the engine output classification.

Over the past several years, KUBOTA has been supplying diesel engines that comply with regulations in the respective countries affected by Non-Road Emission regulations. For KUBOTA Engines, E4B will be the designation that identifies engine models affected by the next emission phase (See the table below).

When servicing or repairing ###-E4B series engines, use only replacement parts for that specific E4B engine, designated by the appropriate E4B KUBOTA Parts List and perform all maintenance services listed in the appropriate KUBOTA Operator's Manual or in the appropriate E4B KUBOTA Workshop Manual. Use of incorrect replacement parts or replacement parts from other emission level engines (for example: E2B engines), may result in emission levels out of compliance with the original E4B design and EPA or other applicable regulations. Please refer to the emission label located on the engine head cover to identify Output classification and Emission Control Information. E4B engines are identified with "EF" at the end of the Model designation, on the US EPA label. Please note : E4B is not marked on the engine.

Category (1)	Engine output classification	EPA regulation
EF	Less than 19 kW	Tier 4

(1) "E4B" engines are identified with "EF" at the end of the Model designation, on the US EPA label.
 "E4B" designates Tier 4, depending on engine output classification.

W1030236

(1)

EMISSION CONTROL INFORMATION ☐

THIS ENGINE MEETS 2008 ##### EMISSION REGULATIONS FOR U. S. EPA AND CALIFORNIA NONROAD CY ENGINES.

Kubota KUBOTA Corporation

MODEL : ###-**EF** : ENGINE DISP. : #####
 FAMILY : 8 ##### ECS : EM
 OUTPUT : ## kW / ### rpm CATEGORY : ## - ## kW
 VALVE CLEARANCE (COLD) : IN ## mm EX ## mm
 INJ. TIMING : ### DEG BTDC
 ULTRA LOW SULFUR FUEL ONLY

CONTACT KUBOTA FOR FUEL SETTING. #####

9Y1210785GE001A

[3] CYLINDER NUMBER

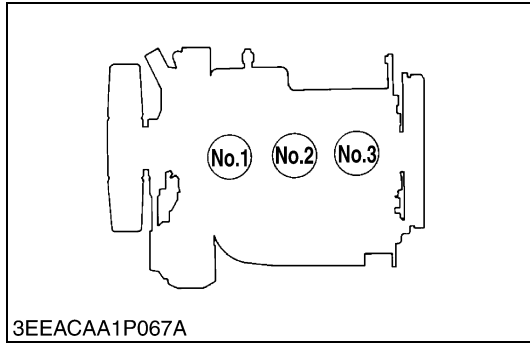

The cylinder numbers of KUBOTA diesel engine are designated as shown in the figure.

The sequence of cylinder numbers is given as No.1, No.2 and No.3 starting from the gear case side.

W1011077

2. PRECAUTION

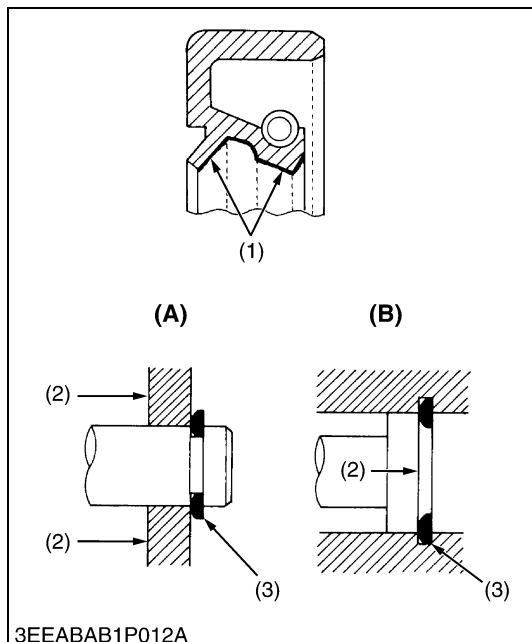

- During disassembly, carefully arrange removed parts in a clean area to prevent confusion later. Screws, bolts and nuts should be replaced in their original position to prevent reassembly errors.
- When special tools are required, use KUBOTA genuine special tools. Special tools which are not frequently used should be made according to the drawings provided.
- Before disassembling or servicing live wires, make sure to always disconnect the grounding cable from the battery first.
- Remove oil and dirt from parts before measuring.
- Use only KUBOTA genuine parts for parts replacement to maintain engine performance and to ensure safety.
- Gaskets and O-rings must be replaced during reassembly. Apply grease to new O-rings or oil seals before assembling.
- When reassembling external or internal snap rings, position them so that the sharp edge faces against the direction from which force is applied.
- Be sure to perform run-in the serviced or reassembled engine. Do not attempt to give heavy load at once, or serious damage may result to the engine.

- (1) Grease
 (2) Force
 (3) Place the Sharp Edge against the Direction of Force

(A) External Snap Ring
 (B) Internal Snap Ring

W10109040

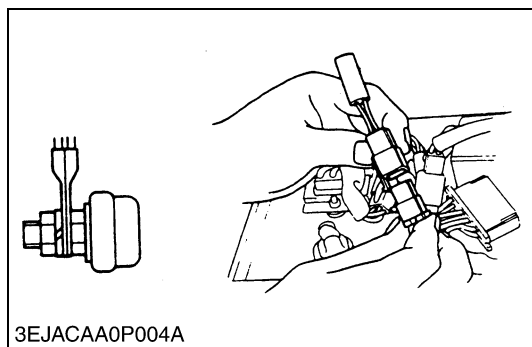

- Before checking any generator or engine electrical component, be sure to check that all terminals and connectors are tight.
- After the individual component inspection, also inspect the wire leads for continuity; that might be the cause of the problem.
- The rotor and stator must be protected when disassembling and reassembling.
 If they are damaged, no power can be generated.
- To maintain the generator's performance and ensure safety, use only KUBOTA genuine parts for replacement.
- Use extreme caution when working on electrical components. Electrical shocks cause injury or death.

W10262580

3. HANDLING PRECAUTIONS FOR ELECTRICAL PARTS AND WIRING

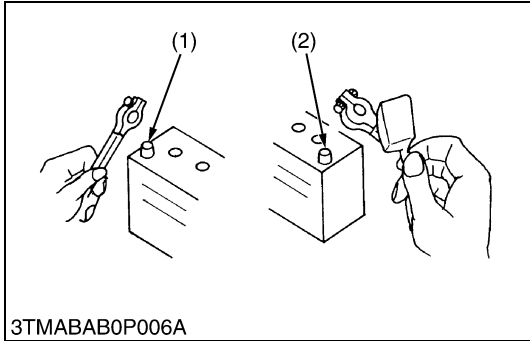

3TMABAB0P006A

To ensure safety and prevent damage to the machine and surrounding equipment, heed the following precautions in handling electrical parts and wiring.

■ IMPORTANT

- Check electrical wiring for damage and loosened connection every year. To this end, educate the customer to do his or her own check and at the same time recommend the dealer to perform periodic check for a fee.
- Do not attempt to modify or remodel any electrical parts and wiring.
- When removing the battery cables, disconnect the negative cable first. When installing the battery cables, connect the positive cable first.

- (1) Negative Terminal (2) Positive Terminal

W10111140

[1] WIRING

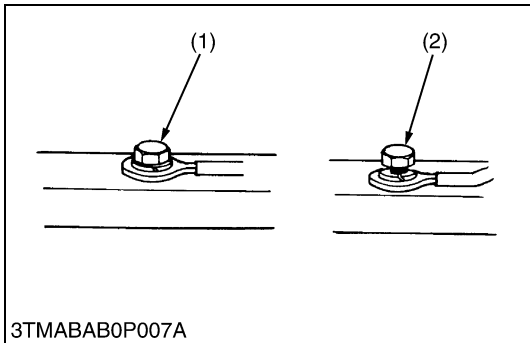

3TMABAB0P007A

- Securely tighten wiring terminals.

- (1) Correct (Securely Tighten) (2) Incorrect (Loosening Leads to Faulty Contact)

W10112160

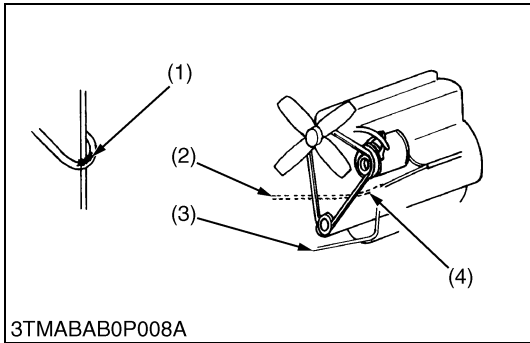

3TMABAB0P008A

- Do not let wiring contact dangerous part.

- (1) Dangerous Part (2) Wiring (Incorrect) (3) Wiring (Correct) (4) Dangerous Part

W10113130

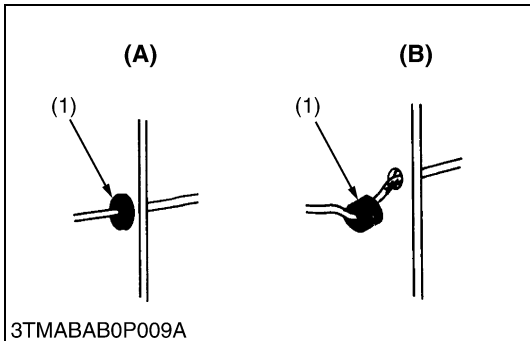

3TMABAB0P009A

- Securely insert grommet.

- (1) Grommet (A) Correct (B) Incorrect

W10113880

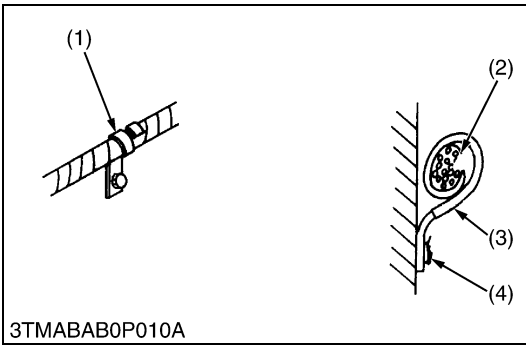

- Securely clamp, being careful not to damage wiring.
- (1) Clamp
 • Wind Clamp Spirally
 (2) Wire Harness
- (3) Clamp
 (4) Welding Dent

W10114580

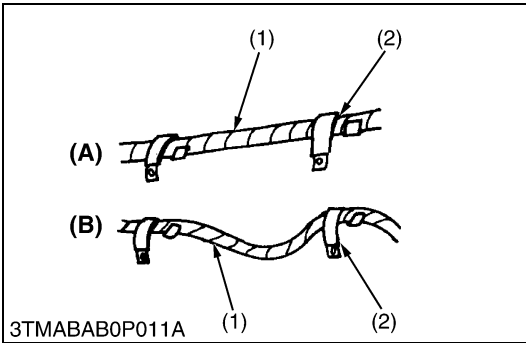

- Clamp wiring so that there is no twist, unnecessary sag, or excessive tension, except for movable part, where sag be required.

- (1) Wiring
 (2) Clamp
- (A) Correct
 (B) Incorrect

W10115870

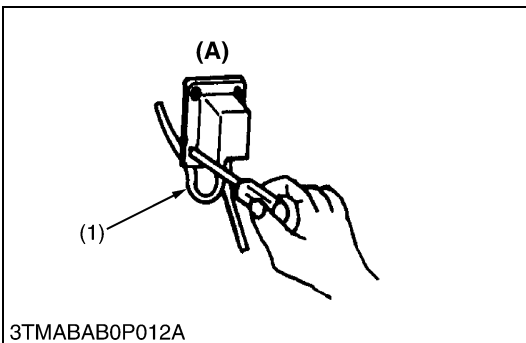

- In installing a part, take care not to get wiring caught by it.

- (1) Wiring
 (A) Incorrect

W10116700

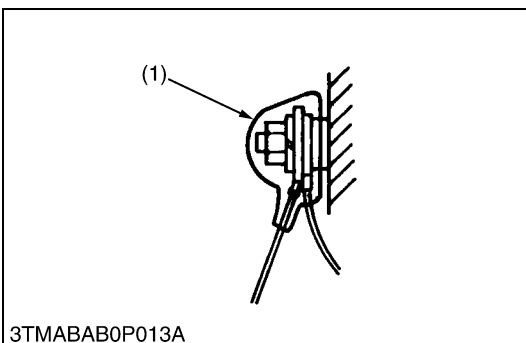

- After installing wiring, check protection of terminals and clamped condition of wiring, only connect battery.

- (1) Cover
 • Securely Install Cover

W10117350

[2] BATTERY

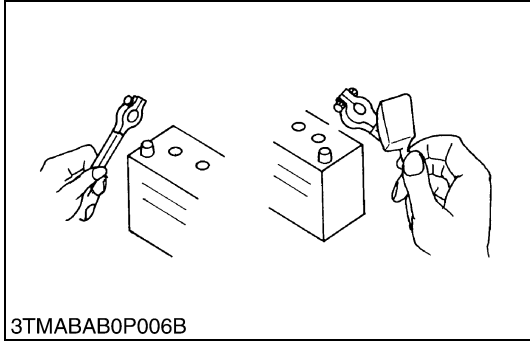

- Take care not to confuse positive and negative terminal posts.
- When removing battery cables, disconnect negative cable first. When installing battery cables, check for polarity and connect positive cable first.
- Do not install any battery with capacity other than is specified (Ah).
- After connecting cables to battery terminal posts, apply high temperature grease to them and securely install terminal covers on them.
- Do not allow dirt and dust to collect on battery.

CAUTION

- Take care not to let battery liquid spill on your skin and clothes. If contaminated, wash it off with water immediately.
- Before recharging the battery, remove it from the machine.
- Before recharging, remove cell caps.
- Do recharging in a well-ventilated place where there is no open flame nearby, as hydrogen gas and oxygen are formed.

W10118160

[3] FUSE

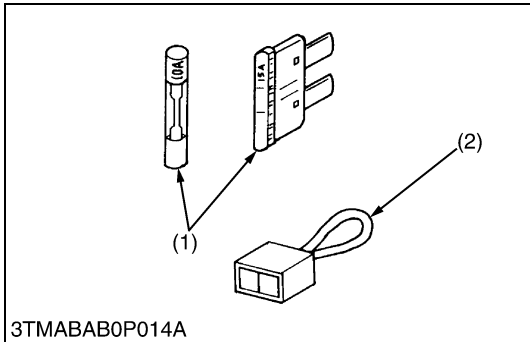

- Use fuses with specified capacity. Neither too large or small capacity fuse is acceptable.
- Never use steel or copper wire in place of fuse.
- Do not install working light, radio set, etc. on machine which is not provided with reserve power supply.
- Do not install accessories if fuse capacity of reserve power supply is exceeded.

(1) Fuse

(2) Slow Blow Fuse

W10120920

[4] CONNECTOR

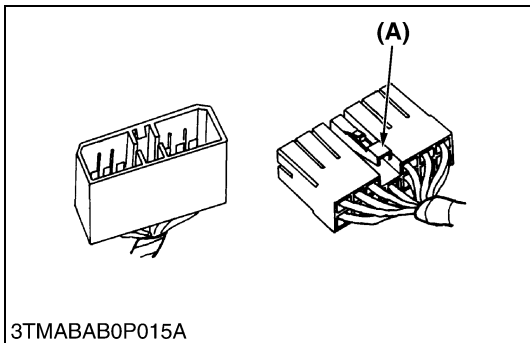

- For connector with lock, push lock to separate.

(A) Push

W10122110

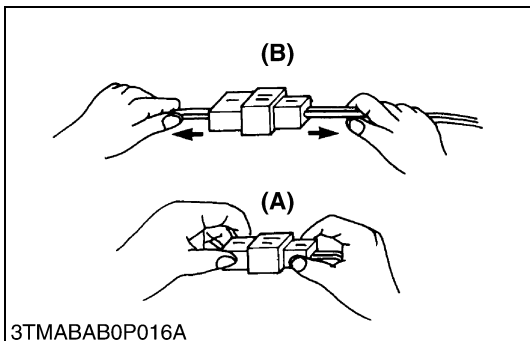

- In separating connectors, do not pull wire harnesses.
- Hold connector bodies to separate.

(A) Correct

(B) Incorrect

W10122720

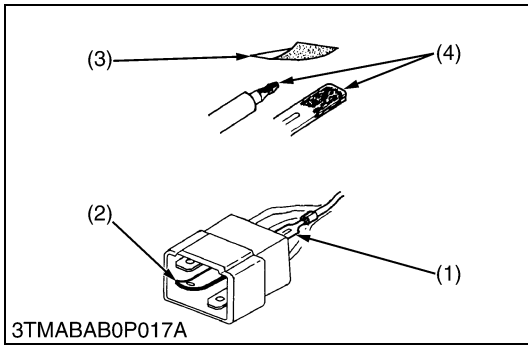

- Use sandpaper to remove rust from terminals.
- Repair deformed terminal. Make certain there is no terminal being exposed or displaced.

(1) Exposed Terminal (3) Sandpaper
 (2) Deformed Terminal (4) Rust

W10123460

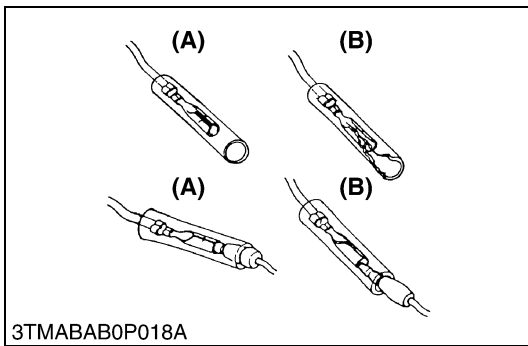

- Make certain that there is no female connector being too open.

(A) Correct (B) Incorrect

W10124300

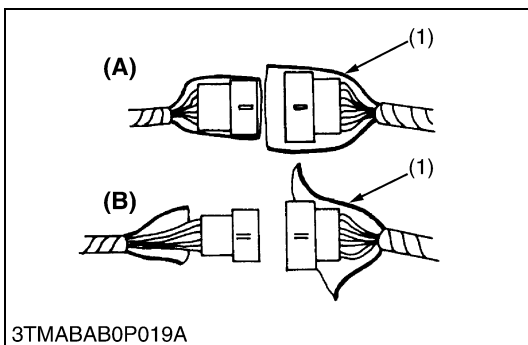

- Make certain plastic cover is large enough to cover whole connector.

(1) Cover (A) Correct
 (B) Incorrect

W10125190

[5] HANDLING OF CIRCUIT TESTER

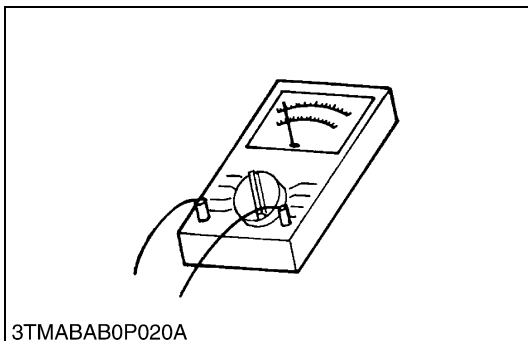

- Use tester correctly following manual provided with tester.
- Check for polarity and range.

W10126840

4. LUBRICANTS, FUEL AND COOLANT

No.	Place	Capacity		Lubricants, fuel and coolant
		GL6000-STD GL6000-AUS GL7000-STD GL7000-USA GL7000-USA-TM	GL9000-STD GL9000-AUS GL11000-STD GL11000-USA GL11000-USA-TM	
1	Engine oil	2.2 L 2.3 U.S.qts. 1.9 Imp.qts.	3.4 L 3.6 U.S.qts. 3.0 Imp.qts.	Higher than CF class (API) Above 25 °C (77 °F) : SAE10W-30, SAE10W-30, SAE30 0 to 25 °C (32 to 77 °F) : SAE10W-30, SAE10W-40, SAE20 Below 0 °C (32 °F) : SAE10W-30, SAE10W-40, SAE10
2	Fuel	28 L 7.4 U.S.gals. 6.2 Imp.gals.		Refer to NOTE
3	Coolant	3.7 L 3.9 U.S.qts. 3.3 Imp.qts.	4.1 L 4.3 U.S.qts. 3.6 Imp.qts.	Clean water (Soft water) Use antifreeze 50 / 50

■ NOTE

Engine Oil :

- Refer to the following table for the suitable American Petroleum Institute (API) classification of engine oil according to the engine type (with internal EGR, external EGR or non-EGR) and the Fuel Type Used : (Low Sulfur, Ultra Low Sulfur or High Sulfur Fuels).

Fuel Type	Engine oil classification (API classification)	
	Engines with non-EGR Engines with internal EGR	Engines with external EGR
High Sulfur Fuel [0.05 % (500 ppm) ≤ Sulfur Content < 0.50 % (5000 ppm)]	CF (If the "CF-4, CG-4, CH-4, or CI-4" engine oil is used with a high-sulfur fuel, change the engine oil at shorter intervals. (approximately half))	–
Low Sulfur Fuel [Sulfur Content < 0.05 % (500 ppm)] or Ultra Low Sulfur Fuel [Sulfur Content < 0.0015 % (15 ppm)]	CF, CF-4, CG-4, CH-4 or CI-4	CF or CI-4 (Class CF-4, CG-4 and CH-4 engine oils cannot be used on EGR type engines.)

EGR : Exhaust Gas Re-circulation

- CJ-4 classification oil is intended for use in engines equipped with DPF (Diesel Particulate Filter) and is Not Recommended for use in KUBOTA E3 specification engines.**
- Oil used in the engine should have API classification and Proper SAE Engine Oil Viscosity according to the ambient temperatures where the engine is operated.**
- With strict emission control regulations now in effect, the CF-4 and CG-4 engine oils have been developed for use with low sulfur fuels, for On-Highway vehicle engines. When a Non-Road engine runs on high sulfur fuel, it is advisable to use a "CF or better" classification engine oil with a high Total Base Number (a minimum TBN of 10 is recommended).**

Fuel :

- Cetane Rating : The minimum recommended Fuel Cetane Rating is 45. A cetane rating greater than 50 is preferred, especially for ambient temperatures below –20 °C (–4 °F) or elevations above 1500 m (5000 ft).**
- Diesel Fuel Specification Type and Sulfur Content % (ppm) used, must be compliant with all applicable emission regulations for the area in which the engine is operated.**
- Use of diesel fuel with sulfur content less than 0.10 % (1000 ppm) is strongly recommended.**
- If high-sulfur fuel (sulfur content 0.50 % (5000 ppm) to 1.0 % (10000 ppm)) is used as a diesel fuel, change the engine oil and oil filter at shorter intervals. (approximately half)**
- DO NOT USE Fuels that have sulfur content greater than 1.0 % (10000 ppm).**
- Diesel fuels specified to EN 590 or ASTM D975 are recommended.**
- No.2-D is a distillate fuel of lower volatility for engines in industrial and heavy mobile service. (SAE J313 JUN87)**
- Since KUBOTA diesel engines of less than 56 kW (75 hp) utilize EPA Tier 4 and Interim Tier 4 standards, the use of low sulfur fuel or ultra low sulfur fuel is mandatory for these engines, when operated in US EPA regulated areas. Therefore, please use No.2-D S500 or S15 diesel fuel as an alternative to No.2-D, and use No.1-D S500 or S15 diesel fuel as an alternative to No.1-D for ambient temperatures below –10 °C (14 °F).**

1) SAE : Society of Automotive Engineers

2) EN : European Norm

3) ASTM : American Society of Testing and Materials

4) US EPA : United States Environmental Protection Agency



5) No.1-D or No.2-D, S500 : Low Sulfur Diesel (LSD) less than 500 ppm or 0.05 wt.%

No.1-D or No.2-D, S15 : Ultra Low Sulfur Diesel (ULSD) 15 ppm or 0.0015 wt.%

5. TIGHTENING TORQUES

[1] GENERAL USE SCREWS, BOLT AND NUTS

Screws, bolt and nuts whose tightening torque are not specified in this Workshop Manual should be tightened according to the table below.

Indication on top of bolt	  No-grade or 4T						 7T					
Material of bolt	SS400, S20C						S43C, S48C					
Material of opponent part	Ordinariness			Aluminum			Ordinariness			Aluminum		
Diameter \ Unit	N·m	kgf·m	lbf·ft	N·m	kgf·m	lbf·ft	N·m	kgf·m	lbf·ft	N·m	kgf·m	lbf·ft
M4 (4 mm, 0.16 in.)	1.00 to 2.90	0.10 to 0.30	0.70 to 2.10	-	-	-	-	-	-	-	-	-
M5 (5 mm, 0.20 in.)	1.90 to 3.60	0.20 to 0.40	1.40 to 2.70	-	-	-	-	-	-	-	-	-
M6 (6 mm, 0.24 in.)	7.85 to 9.31	0.80 to 0.95	5.79 to 6.87	7.85 to 8.82	0.80 to 0.90	5.79 to 6.50	9.81 to 11.2	1.00 to 1.15	7.24 to 8.31	7.85 to 8.82	0.80 to 0.90	5.79 to 6.50
M8 (8 mm, 0.31 in.)	17.7 to 20.5	1.8 to 2.1	13.1 to 15.1	16.7 to 19.6	1.7 to 2.0	12.3 to 14.4	23.6 to 27.4	2.4 to 2.8	17.4 to 20.2	17.7 to 20.5	1.8 to 2.1	13.1 to 15.1
M10 (10 mm, 0.39 in.)	39.3 to 45.1	4.0 to 4.6	29.0 to 33.2	31.4 to 34.3	3.2 to 3.5	23.2 to 25.3	48.1 to 55.8	4.9 to 5.7	35.5 to 41.2	39.3 to 44.1	4.0 to 4.5	29.0 to 32.5
M12 (12 mm, 0.47 in.)	62.8 to 72.5	6.4 to 7.4	46.3 to 53.5	-	-	-	77.5 to 90.2	7.9 to 9.2	57.2 to 66.5	62.8 to 72.5	6.4 to 7.4	46.3 to 53.5
M14 (14 mm, 0.55 in.)	108 to 125	11.0 to 12.8	79.6 to 92.5	-	-	-	124 to 147	12.6 to 15.0	91.2 to 108	-	-	-

W1034542

[2] STUD BOLTS

Material of opponent part	Ordinariness			Aluminum		
Diameter \ Unit	N·m	kgf·m	lbf·ft	N·m	kgf·m	lbf·ft
M8 (8 mm, 0.31 in.)	11.8 to 15.6	1.2 to 1.6	8.68 to 11.5	8.82 to 11.8	0.90 to 1.2	6.51 to 8.67
M10 (10 mm, 0.39 in.)	24.6 to 31.3	2.5 to 3.2	18.1 to 23.1	19.7 to 25.4	2.0 to 2.6	14.5 to 18.8

W1048139

6. MAINTENANCE CHECK LIST

Observe the following for service and maintenance.

The lubricating oil change intervals listed in the table below are for classes CG, CE and CD lubricating oil of API classification with a low-sulfur fuel in use. If the CF-4 of CG-4 lubricating oil is used with a high-sulfur fuel, change the lubricating oil at shorter intervals than recommended in the table below depending on the operating condition.



CAUTION

- When checking and servicing the generator, be sure to level and stop the engine.

No.	Item	Period	Daily	Initial 50 hours	Every 50 hours	Every 100 hours	Every 200 hours	Every 300 hours	Every 400 hours	Every 500 hours	Reference page
1	Engine oil	Check	☆								G-14
		Change		☆		☆					G-15, 16
2	Radiator coolant (L.L.C.)	Check	☆								G-14
		Change									G-24
3	Air cleaner element	Clean				☆					G-17
		Change									G-24
4	Fan belt	Check				☆					G-17
		Change									G-23
5	Fuel line (Fuel hose and clamp bands)	Check			☆						G-16
		Change									G-25
6	Battery	Check		☆		☆					G-15, 17
		Change									G-25
7	Radiator hose and clamp bands	Check					☆				G-18
		Change									G-25
8	Oil filter cartridge	Change		☆			☆				G-15, 18
9	Fuel filter element	Clean				☆					G-18
		Change							☆		G-19
10	Valve clearance	Check									G-22
11	Water jacket (Radiator interior)	Clean								☆	G-20
12	Generator's brush ware	Check						☆			G-19
13	Generator's slip-ring	Check						☆			G-19
14	Generator's ball bearing	Check									G-23
15	Damage in electric wiring and loose connections	Check									2-M8
16	Fuel injection pressure	Check									G-23
17	Nozzle spraying condition	Check									G-23
18	Nozzle valve seat tightness	Check									G-23

No.	Item	Period	Every	Every	Every	Every 1	Every 2	Reference page
			800 hours	1000 hours	1500 hours	year	year	
1	Engine oil	Check						G-14
		Change						G-15, 16
2	Radiator coolant (L.L.C.)	Check						G-14
		Change					☆	G-24
3	Air cleaner element	Clean						G-17
		Change				☆		G-24
4	Fan belt	Check						G-17
		Change	☆					G-23
5	Fuel line (Fuel line and clamps)	Check						G-16
		Change					☆	G-25
6	Battery	Check						G-15, 17
		Change					☆	G-25
7	Radiator hose and clamps	Check						G-18
		Change					☆	G-25
8	Oil filter cartridge	Change						G-15, 18
9	Fuel filter element	Clean						G-18
		Change						G-19
10	Valve clearance	Check	☆					G-22
11	Water jacket (Radiator interior)	Clean						G-20
12	Generator's brush ware	Check						G-19
13	Generator's slip-ring	Check						G-19
14	Generator's ball bearing	Check		☆				G-23
15	Damage in electric wiring and loose connections	Check				☆		2-M8
16	Fuel injection pressure	Check			☆			G-23
17	Nozzle spraying condition	Check			☆			G-23
18	Nozzle valve seat tightness	Check			☆			G-23

W1036740

7. CHECK AND MAINTENANCE

[1] DAILY CHECK



Checking Engine Oil Level

⚠ CAUTION

- **Be sure to stop the engine before checking the engine oil level.**
1. Level the engine and check the oil level on the gauge (1).
 2. If the level below the lower mark, add new engine oil to the upper mark.

■ IMPORTANT

- **When using an oil of different maker or viscosity from the previous one, drain an old oil.**
 - **Never mix two different type's of oil.**
 - **Use the proper SAE Engine oil according to ambient temperatures.**
- Refer to "4. LUBRICANTS, FUEL AND COOLANT" (G-9).**

(1) Gauge

W1021730



Checking Coolant Level

⚠ CAUTION

- **Do not remove the radiator cap while operating or immediately after stopping. Otherwise, hot water will spout out from the radiator. Wait for more than ten minutes to cool the radiator, before opening the cap.**
1. Remove the radiator cap and check to see that the coolant level is just below the port.
 2. If low, add coolant to the radiator.
 3. Check the reserve tank (1) and keep the coolant level between the **"FULL"** and **"LOW"** marks.
 4. If low, add coolant to the reserve tank (1).

(1) Reserve Tank

W1040218

[2] CHECK POINTS OF INITIAL 50 HOURS

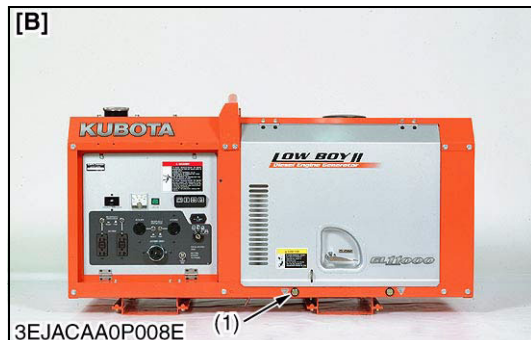

Changing Engine Oil

⚠ CAUTION

- **Be sure to stop engine before changing engine oil.**
1. After warming up, stop the engine.
 2. Place an oil pan underneath the engine.
 3. Remove the oil drain plug (1) to drain the dirty engine oil completely.
 4. Inspect the drain plug gasket. Replace it damaged.
 5. Reinstall the drain plug.
 6. Fill the new engine oil up to the upper mark on the gauge.

■ IMPORTANT

- **When using an oil of different maker or viscosity from the previous one, drain an old oil.**
 - **Never mix two different type's of oil.**
 - **Use the proper SAE Engine oil according to ambient temperatures.**
- Refer to "4. LUBRICANTS, FUEL AND COOLANT" (G-9).**

(1) Oil Drain Plug

[A] GL6000, GL7000

[B] GL9000, GL11000

W1016604



Changing Engine Oil Filter Cartridge

⚠ CAUTION

- **Be sure to stop the engine before changing the engine oil filter cartridge.**
1. Remove the engine oil filter cartridge (1) with the filter wrench.
 2. Apply engine oil slightly to the rubber gasket of new cartridge.
 3. Install the new cartridge, screwing it in by hand.
Over-tightening may cause deformation of the rubber gasket.
 4. After the cartridge has been changed, the engine oil level normally lowers a little. Add engine oil to proper level.

■ IMPORTANT

- **To prevent serious damage to the engine, replacement element must be highly efficient. Use only a KUBOTA genuine filter or its equivalent.**

(1) Engine Oil Filter Cartridge

W1017137

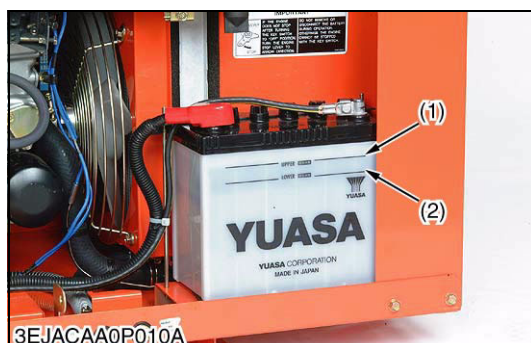

Checking Battery Electrolyte Level

1. Check the battery electrolyte level.
2. If the level is below than lower level line (2), add the distilled water to pour level of each cell.
3. If the battery can not be charged even though the electrolyte level is correct, replace the battery.

(1) Upper Level Line

(2) Lower Level Line

W1041720

[3] CHECK POINT OF EVERY 50 HOURS

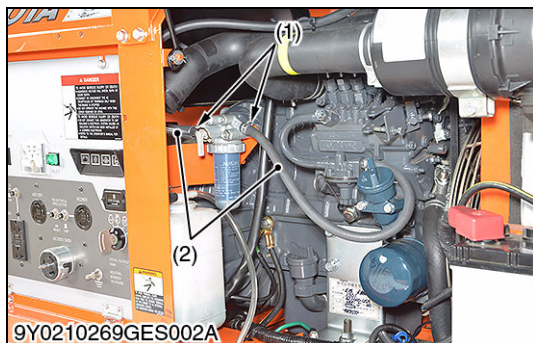

Checking Fuel Hose and Clamp Bands

⚠ CAUTION

- Stop the engine when attempting the check and change prescribed below.
- Remember to check the fuel line periodically. The fuel line is subject to wear and aging, fuel may leak out onto the running engine, causing a fire.

1. Check to see that all fuel lines (2) and hose clamps (1) are tight and not damaged.
2. If fuel lines (2) and hose clamps (1) are found worn or damaged, replace or repair them at once.
3. The fuel line (2) is made of rubber and ages regardless of period of service. Replace the fuel line (2) together with the hose clamp (1) every two years and securely tighten.
4. However if the fuel lines (2) and hose clamps (1) are found damaged or deteriorated earlier than two years, then change or remedy.

■ IMPORTANT

- When the fuel line is disconnected for change, close both ends of the fuel line with a piece of clean cloth or paper to prevent dust and dirt from entering. Entrance of dust and dirt causes malfunction of the fuel injection pump. In addition, particular care must be taken not to admit dust and dirt into the fuel pump.

(1) Hose Clamp

(2) Fuel Line

W1035921

[4] CHECK POINT OF EVERY 100 HOURS



Changing Engine Oil

⚠ CAUTION

- Be sure to stop engine before changing engine oil.
1. After warming up, stop the engine.
 2. Place an oil pan underneath the engine.
 3. Remove the oil drain plug (1) to drain the dirty engine oil completely.
 4. Inspect the drain plug gasket. Replace it damaged.
 5. Reinstall the drain plug.
 6. Fill the new engine oil up to the upper mark on the gauge.

■ IMPORTANT

- When using an oil of different maker or viscosity from the previous one, drain an old oil.
- Never mix two different types' of oil.
- Use the proper SAE Engine oil according to ambient temperatures.

Refer to "4. LUBRICANTS, FUEL AND COOLANT" (G-9).

(1) Oil Drain Plug

[A] GL6000, GL7000

[B] GL9000, GL11000

W1014131

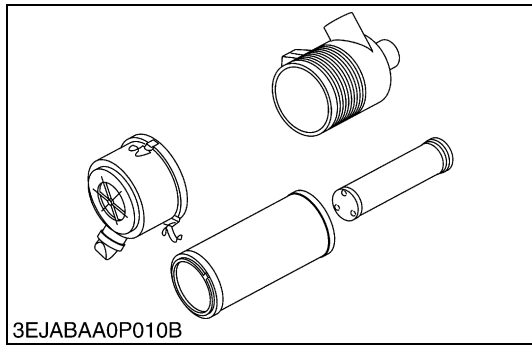

3EJABAA0P010B

Checking Air Cleaner Element

1. Remove the air cleaner element.
2. Use clean dry compressed air on the inside of the element.
Pressure of compressed air must be under 205 kPa (2.1 kgf/cm², 30 psi).
Maintain reasonable distance between the nozzle and the filter.

NOTE

- The air cleaner uses a dry element. Never apply oil to it
- Be sure to refit the dust cup with arrow ↑ (on the rear) upright. If the dust cup is improperly fitted, dust passes by the dust cup and directly adheres to the element.
- Do not run the engine with filter element removed.
- Change the element once a year or every 6th cleaning

W1043003

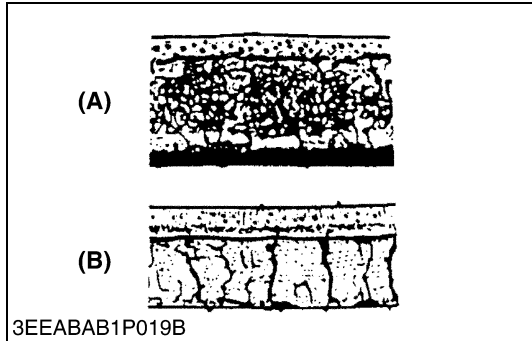

3EEABAB1P019B

Fan Belt Damage and Wear

1. Check the fan belt for damage.
2. If the fan belt is damaged, replace it.
3. Check if the fan belt is worn and sunk in the pulley groove.
4. If the fan belt is nearly worn out and deeply sunk in the pulley groove, replace it.

(A) Good

(B) Bad

W1209480

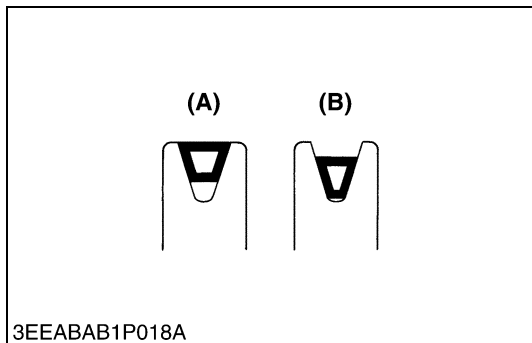

3EEABAB1P018A

Fan Belt Tension

1. Measure the deflection (A), depressing the belt halfway between the fan drive pulley and alternator pulley at specified force 98 N (10 kgf, 22 lbf).
2. If the measurement is not within the factory specifications, loosen the alternator mounting screws and relocate the alternator to adjust.

Deflection (A)	Factory spec.	7.0 to 9.0 mm 0.28 to 0.35 in.
----------------	---------------	-----------------------------------

(A) Deflection

W1208957

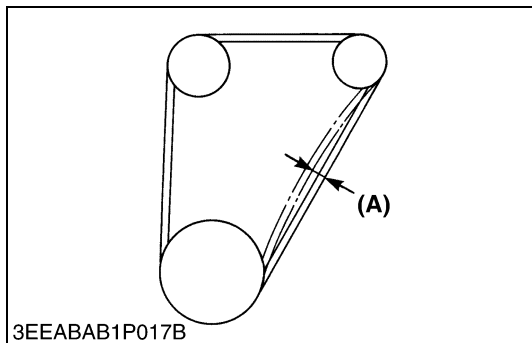

3EEABAB1P017B

Checking Battery Electrolyte Level

1. Check the battery electrolyte level.
2. If the level is below than lower level line (2), add the distilled water to pour level of each cell.
3. If the battery can not be charged even though the electrolyte level is correct, replace the battery.

(1) Upper Level Line

(2) Lower Level Line

W1045746

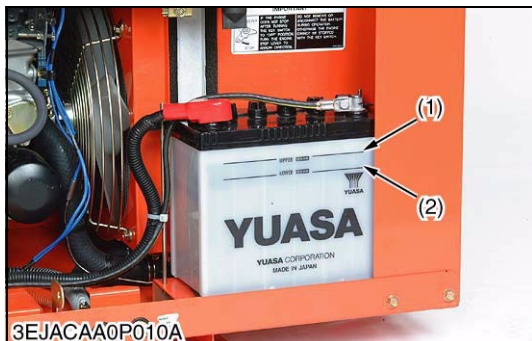

3EJACAA0P010A

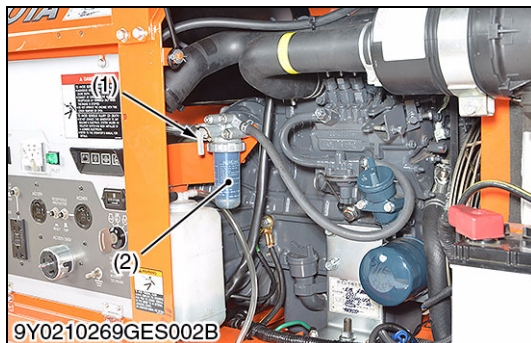

Checking Fuel Filter Element

1. Close the fuel valve (1).
2. Remove the fuel filter element (2).
3. After cleaning the fuel filter element (2), screwing it in by hand.

■ NOTE

- Check for fuel leak after checking it.

(1) Fuel Valve (2) Fuel Filter Element

W1046058

[5] CHECK POINT OF EVERY 200 HOURS

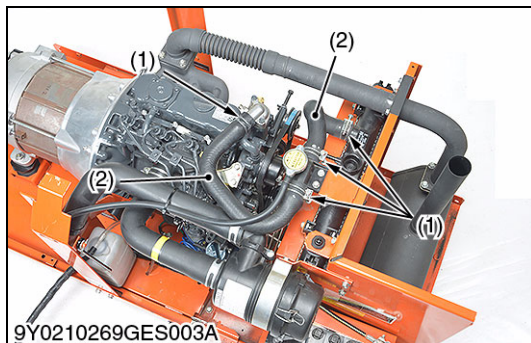

Checking Radiator Hose and Clamp Bands

1. Check to see if the radiator hoses (2) are properly fixed every 200 hours of operation or every six months, whichever comes first.
2. If clamp bands (1) are loose or water leaks, tighten bands securely. Replace hoses and tighten clamp bands securely, if radiator hoses are swollen, hardened or cracked.
3. Replace hoses and clamp bands every 2 years or earlier if checked and found that hoses are swollen, hardened or cracked.

(1) Clamp Band (2) Radiator Hose

W1014590



Changing Engine Oil Filter Cartridge

⚠ CAUTION

- Be sure to stop the engine before changing the engine oil filter cartridge.

1. Remove the engine oil filter cartridge (1) with the filter wrench.
2. Apply engine oil slightly to the rubber gasket of new cartridge.
3. Install the new cartridge, screwing it in by hand.
Over-tightening may cause deformation of the rubber gasket.
4. After the cartridge has been changed, the engine oil level normally lowers a little. Add engine oil to proper level.

■ IMPORTANT

- To prevent serious damage to the engine, replacement oil filter cartridge must be highly efficient. Use only a genuine KUBOTA filter cartridge or its equivalent.

(1) Engine Oil Filter Cartridge

W1015117



[6] CHECK POINT OF EVERY 300 HOURS

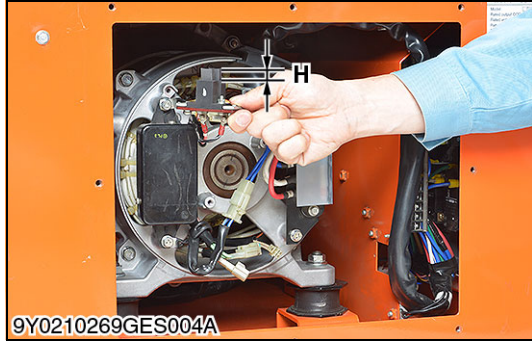

Checking Generator's Brush Wear

1. Check to see if the brush has worn to more than 1/2 below the standard dimensions.
2. If wear exceeds the allowable limit, replace.

Brush length (Stretch out of the Holder)	Standard length	All model	15.0 mm 0.59 in.
	Allowable limit	GL6000, GL7000	4.5 mm 0.18 in.
GL9000, GL11000		7.5 mm 0.30 in.	

H : Brush Length

W1037215

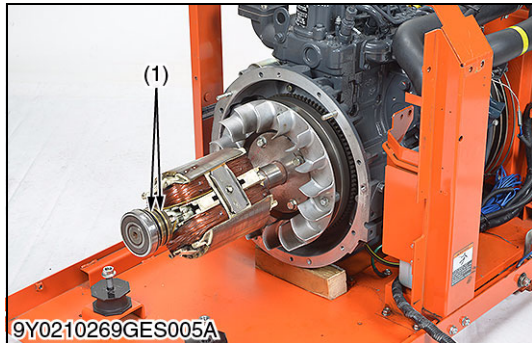

Checking Generator's Slip-ring

1. Check to see if there is no unusual wear and surface roughness.

[GL6000, GL7000]

Slip-ring O.D.	Factory spec.	49.7 mm 1.96 in.
	Correction limit	47.5 mm 1.87 in.

[GL9000, GL11000]

Slip-ring O.D.	Factory spec.	64.0 mm 2.52 in.
	Correction limit	62.5 mm 2.46 in.

(1) Slip-ring

W1046346

[7] CHECK POINT OF EVERY 400 HOURS

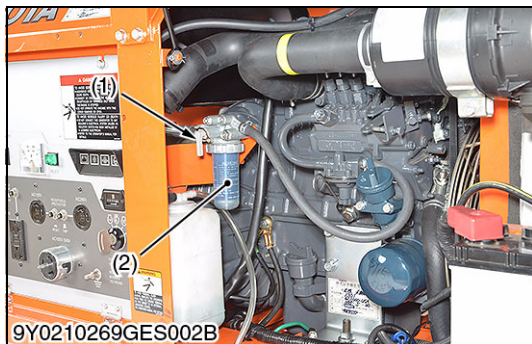

Changing Fuel Filter Element

1. Close the fuel valve (1).
2. Remove the fuel filter element (2).
3. Install the new fuel filter element, screwing it in by hand.

■ NOTE

- Check for fuel leak after replaced it.

(1) Fuel Valve

(2) Fuel Filter Element

W1052658

[8] CHECK POINTS OF EVERY 500 HOURS



Cleaning Water Jacket and Radiator Interior

CAUTION

- Do not remove the radiator cap when the engine is hot. Then loosen cap slightly to the stop to relieve any excess pressure before removing cap completely.

1. Stop the engine and let cool down.
2. To drain the coolant, open the water drain plug (2), and remove radiator cap (1). The radiator cap must be removed to completely drain the coolant.
3. After all coolant is drained, close the water drain plug (2).
4. Fill with clean water and cooling system cleaner.
5. Follow directions of the cleaner instruction.
6. After flushing, fill with clean water and anti-freeze until the coolant level is just below the port.

Install the radiator cap securely.

7. Fill with coolant up to "FULL" mark on the recovery tank (3).
8. Start and operate the engine for few minutes.
9. Stop the engine, remove the key and let cool.
10. Check coolant level of recovery tank (3) and add coolant if necessary.

IMPORTANT

- Do not start engine without coolant.
- Use clean, fresh water and anti-freeze to fill the radiator.
- When the anti-freeze is mixed with water, the anti-freeze mixing ratio must be less than 50 %.
- Securely tighten radiator cap. If the cap is loose or improperly fitted, water may leak out and the engine could overheat.

Refer to "4. LUBRICANTS, FUEL AND COOLANT" (G-9).

- (1) Radiator Cap
(2) Water Drain Plug

- (3) Recovery Tank

W10411400

Cleaning Water Jacket and Radiator Interior (Continued)**■ Anti-Freeze**

If coolant freezes, it can damage the cylinders and radiator. It is necessary, if the ambient temperature falls below 0 °C (32 °F), to remove coolant after operating or to add anti-freeze to it.

1. There are two types of anti-freeze available ; use the permanent type (PT) for this engine.
2. Before adding anti-freeze for the first time, clean the radiator interior by pouring fresh water and draining it a few times.
3. The procedure for mixing of water and anti-freeze differs according to the maker of the anti-freeze and the ambient temperature, basically it should be referred to SAE J1034 standard, more specifically also to SAE J814c.
4. Mix the anti-freeze with water, and then fill in to the radiator.

Vol % Anti-freeze	Freezing Point		Boiling Point*	
	°C	°F	°C	°F
40	-24	-12	106	222
50	-37	-34	108	226

*At 1.013 x 100000 Pa (1.033 kgf/cm²) pressure (atmospheric). A higher boiling points is obtained by using a radiator pressure cap which permits the development of pressure within the cooling system

■ NOTE

- **The above data represents industry standards that necessitate a minimum glycol content in the concentrated anti-freeze.**
- **When the coolant level drops due to evaporation, add water only. In case of leakage, add anti-freeze and water in the specified mixing ratio.**
- **Anti-freeze absorbs moisture. Keep unused anti-freeze in a tightly sealed container.**
- **Do not use radiator cleaning agents when anti-freeze has been added to the coolant. (Anti-freeze contains an anti-corrosive agent, which will react with the radiator cleaning agent forming sludge which will affect the engine parts.)**

W1037674

[9] CHECK POINT OF EVERY 800 HOURS

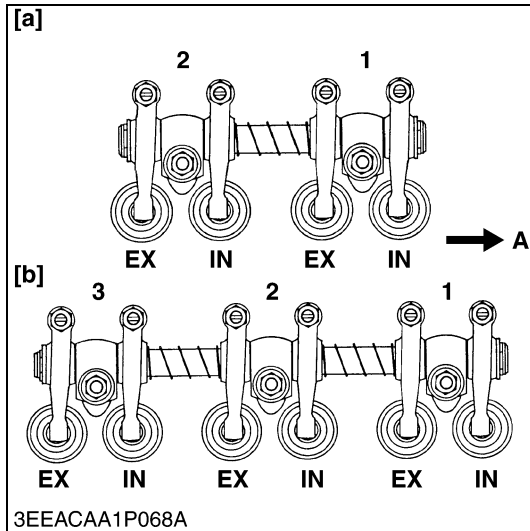
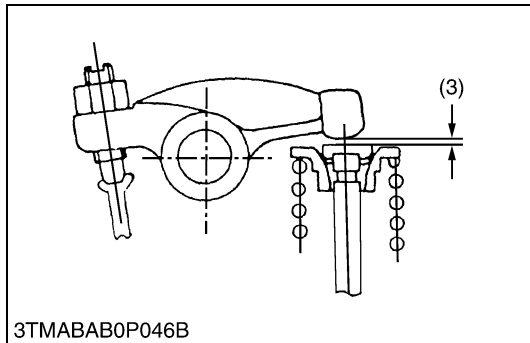
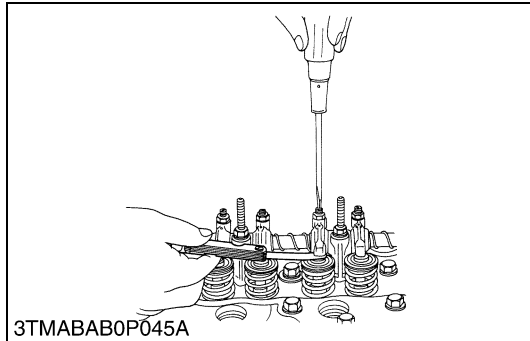
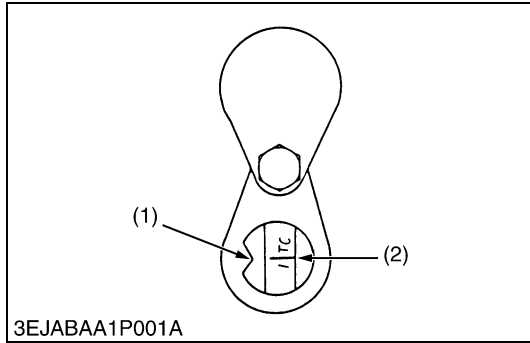

Valve Clearance

■ IMPORTANT

- The valve clearance must be checked and adjusted when engine is cold.
1. Remove the head cover, the glow plugs and the timing window cover on the flywheel housing.
 2. Align the 1TC mark line (2) on the flywheel and center of timing window (1) so that the No. 1 piston comes to the compression or overlap top dead center.
 3. Check the following valve clearance marked with "☆" using a feeler gauge.
 4. If the clearance is not within the factory specifications, adjust with the adjusting screw.

Intake and exhaust valve clearance (Cold)	Factory spec.	0.145 to 0.185 mm 0.00571 to 0.00728 in.
---	---------------	---

■ NOTE

- The "TC" marking line on the flywheel is just for No. 1 cylinder. There is no TC marking for the other cylinders.
- No. 1 piston comes to the top dead center position when the TC marking is aligned with center of timing window on flywheel-housing. Turn the flywheel 0.26 rad (15 °) clockwise and counterclockwise to see if the piston is at the compression top dead center or the overlap position. Now referring to the table below, readjust the valve clearance. (The piston is at the compression top dead center when both the IN. and EX. valves do not move; it is at the overlap position when both the valves move.)
- Finally turn the flywheel 6.28 rad (360 °) and align the TC marking line and the center of timing window. Adjust all the other valve clearance as required.
- After turning the flywheel counterclockwise twice or three times, recheck the valve clearance, firmly tighten the lock nut of the adjusting screw.
- The sequence of cylinder numbers is given as No. 1, No. 2 and No. 3 starting from the gear case side.

Engine valve arrangement	GL6000, GL7000		GL9000, GL11000	
	IN.	EX.	IN.	EX.
Adjustable cylinder location of piston				
No.1	☆	☆	☆	☆
No.2	★	☆	★	☆
No.3	-	-	☆	★

☆ : When No.1 piston is at the compression top dead center position.

★ : When No.1 piston is at the overlap position.

- (1) Timing Window
- (2) 1TC Mark Line
- (3) Valve Clearance

- A : Gear Case Side
- [a] GL6000, GL7000
- [b] GL9000, GL11000

W1022492

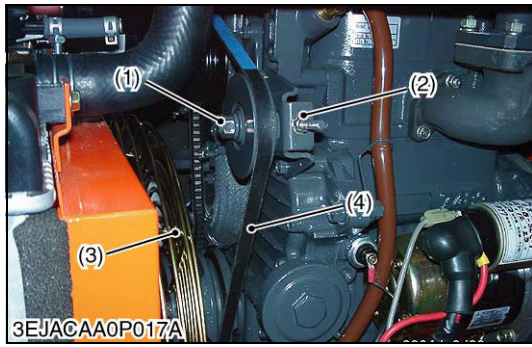

Changing Fan Belt

1. Remove the side panel.
2. Loosen the tension pulley screw (1) and the tension adjustment screw (2).
3. Remove the fan cover (4).
4. Remove the fan belt (3).
5. Install the new fan belt.

- (1) Tension Pulley Screw
- (2) Tension Adjustment Screw
- (3) Fan Belt
- (4) Fan Cover

W1022082

[10] CHECK POINT OF EVERY 1000 HOURS

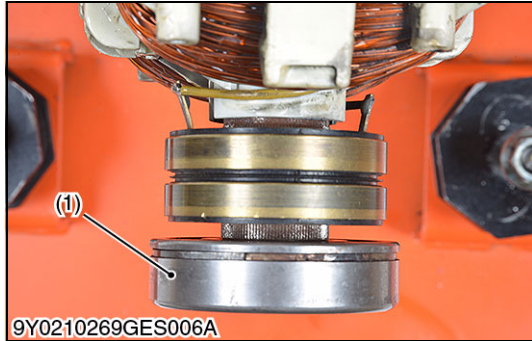

Checking Generator's Ball Bearing

1. Hold the bearing (1), and push and pull the outer race in all directions to check for wear and roughness.
2. Turn the outer race to check rotation.
3. If there is any defect, replace it.

- (1) Ball Bearing

W1024734

[11] CHECK POINT OF EVERY 1500 HOURS

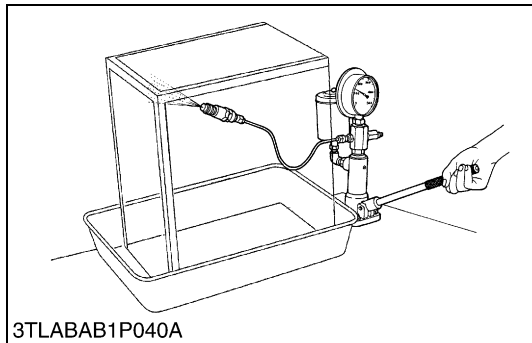

Fuel Injection Pressure

1. Set the injection nozzle to a nozzle tester.
2. Slowly move the tester handle to measure the pressure at which fuel begins jetting out from the nozzle.
3. If the measurement is not within the factory specifications, replace the adjusting washer in the nozzle holder to adjust it.

Fuel injection pressure	Factory spec.	13.73 to 14.71 MPa 140 to 150 kgf/cm ² 1991 to 2134 psi
-------------------------	---------------	--

W10182100

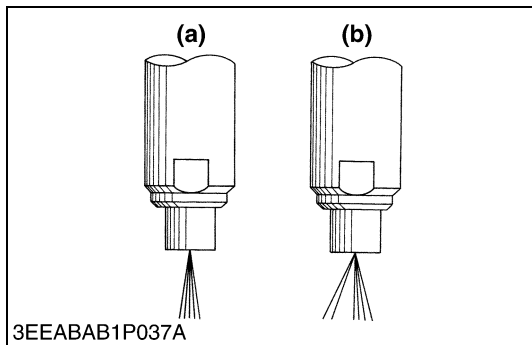

Nozzle Spraying Condition

1. Set the injection nozzle to a nozzle tester, and check the nozzle spraying condition.
2. If the spraying condition is defective, replace the nozzle piece.

- (a) Good
- (b) Bad

W10182120

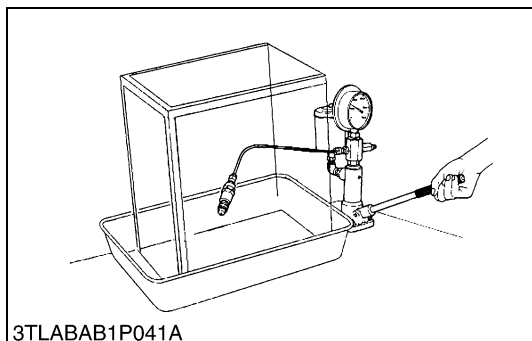

Nozzle Valve Seat Tightness

1. Set the injection nozzle to a nozzle tester.
2. Raise the fuel pressure, and keep at 12.75 MPa (130 kgf/cm², 1849 psi) for 10 seconds.
3. If any fuel leak is found, replace the nozzle piece.

Valve seat tightness	Factory spec.	No fuel leak at 12.75 MPa 130 kgf/cm ² 1849 psi
----------------------	---------------	---

W10182130

[12] CHECK POINT OF EVERY 1 YEAR

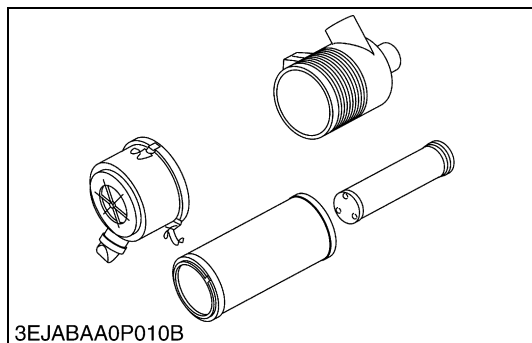

Changing Air Cleaner Element

1. Remove the air cleaner element.
2. Install the new air cleaner element.

■ NOTE

- The air cleaner uses a dry element. Never apply oil to it
- Be sure to refit the dust cup with arrow ↑ (on the rear) upright. If the dust cup is improperly fitted, dust passes by the dust cup and directly adheres to the element.
- Do not run the engine with filter element removed.
- Change the element once a year or every 6th cleaning.

W1019006

Checking Damage in Electric wiring and Loose Connections

1. Check the state of the wiring harness and if it is abnormal, exchange it.
2. Check the connector's loosening and if the connector is loose, connect it firmly.

W1020554

[13] CHECK POINT OF EVERY 2 YEARS



Changing Coolant (L.L.C.)

⚠ CAUTION

- Do not remove the radiator cap when the engine is hot. Then loosen cap slightly to the stop to relieve any excess pressure before removing cap completely.
1. Stop the engine and let cool down.
 2. To drain the coolant, open the water drain plug (2), and remove radiator cap (1). The radiator cap must be removed to completely drain the coolant.
 3. After all coolant is drained, close the water drain plug (2).
 4. Fill with clean water and anti-freeze until the coolant level is just below the port.
Install the radiator cap securely.
 5. Fill with coolant up to "FULL" mark on the recovery tank.
 6. Start and operate the engine for few minutes.
 7. Stop the engine, remove the key and let cool.
 8. Check coolant level of recovery tank and add coolant if necessary.

■ IMPORTANT

- Do not start engine without coolant.
 - Use clean, fresh water and anti-freeze to fill the radiator.
 - When the anti-freeze is mixed with water, the anti-freeze mixing ratio must be less than 50 %.
 - Securely tighten radiator cap. If the cap is loose or improperly fitted, water may leak out and the engine could overheat.
- Refer to "4. LUBRICANTS, FUEL AND COOLANT" (G-9).

(1) Radiator Cap

(2) Water Drain Plug

W1020090

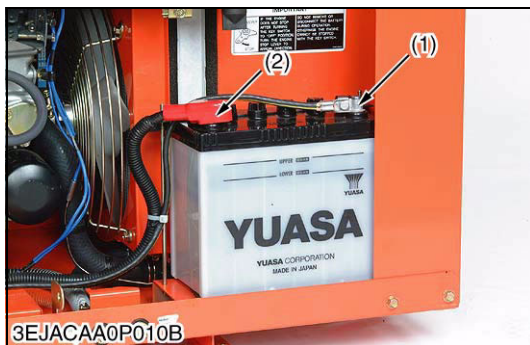
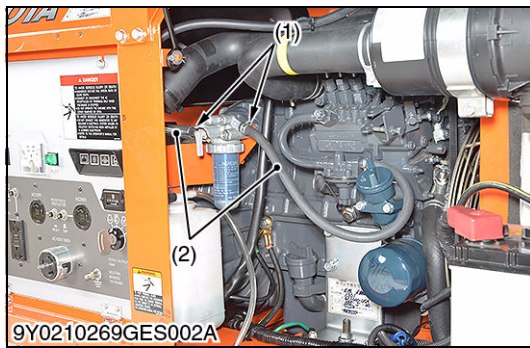
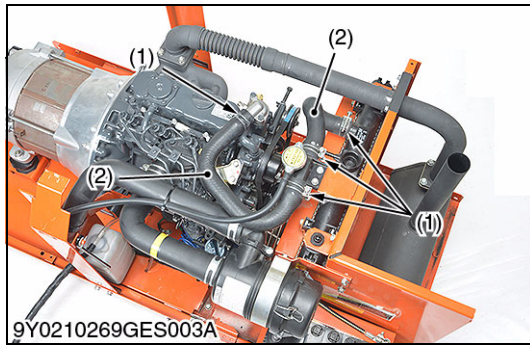

Changing Radiator Hose and Clamp Bands

⚠ CAUTION

- Before changing the radiator hoses and clamps, be sure to stop the engine.
- Never open the pressure cap while the engine is running under heavy loads or immediately after the engine has stopped. Otherwise, hot water may spray out, scalding the operator. So make it a habit to wait for about 10 minutes before opening the cap.

1. To drain the coolant, open the drain cock and remove radiator cap.
2. Change the radiator hoses (2) and clamps bands (1).

(1) Clamp Band

(2) Radiator Hose

W1023996

Changing Fuel Hose and Clamps

⚠ CAUTION

- Stop the engine when attempting to check the fuel line.
- Never fail to check the fuel line periodically. The fuel line is subject to wear and aging, fuel may leak out onto the running engine, causing a fire.

1. Change the fuel hoses (2) together with clamps (1) every 2 years, or whenever they are found to be damaged.

(1) Clamp

(2) Fuel Hose

W1053457

Changing Battery

⚠ CAUTION

- Be sure to stop the engine before disconnecting the cables. When removing the battery cables, disconnect the negative cable first. When installing the battery cables, connect the positive cable first.

1. Open the generator door.
2. Disconnect the cable from the battery negative terminal (1).
3. Disconnect the cable from the battery positive terminal (2).
4. Remove the battery.
5. Install the new battery.

(1) Negative Terminal

(2) Positive Terminal

W1053554

8. SPECIAL TOOLS

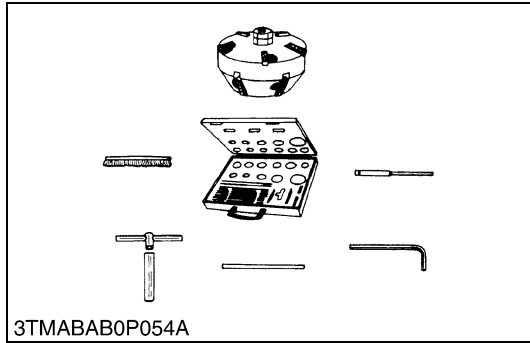

Valve Seat Cutter

Code No: 07909-33102
 Application: Use to reseat valves.
 Angle: 0.785 rad. (45 °)
 0.262 rad. (15 °)
 Diameter: 28.6 mm (1.126 in.) 38.0 mm (1.496 in.)
 31.6 mm (1.244 in.) 41.3 mm (1.626 in.)
 35.0 mm (1.378 in.) 50.8 mm (2.000 in.)

W1024458

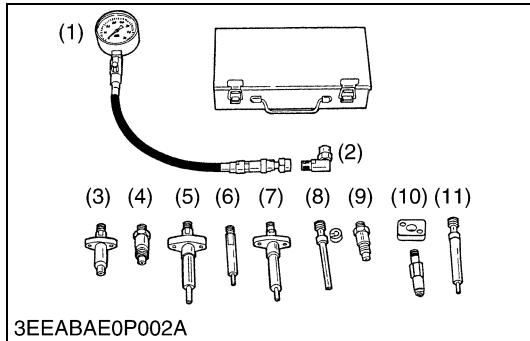

Diesel Engine Compression Tester

Code No: 07909-30208 (Assembly) 07909-31251 (G)
 07909-30934 (A to F) 07909-31271 (I)
 07909-31211 (E and F) 07909-31281 (J)
 07909-31231 (H)

Application: Use to measure diesel engine compression and diagnostics of need for major overhaul.

- | | |
|---------------|----------------|
| (1) Gauge | (7) Adaptor F |
| (2) L Joint | (8) Adaptor G |
| (3) Adaptor A | (9) Adaptor H |
| (4) Adaptor B | (10) Adaptor I |
| (5) Adaptor C | (11) Adaptor J |
| (6) Adaptor E | |

W1024200

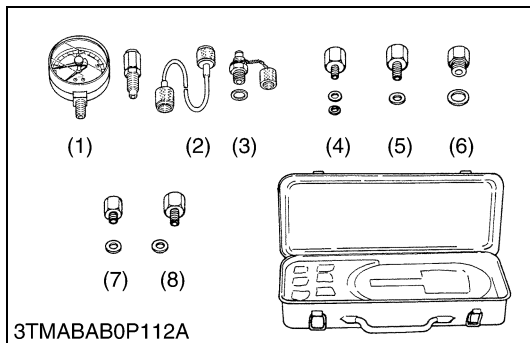

Oil Pressure Tester

Code No: 07916-32032
 Application: Use to measure lubricating oil pressure.

- | | |
|--------------------|---------------|
| (1) Gauge | (5) Adaptor 2 |
| (2) Cable | (6) Adaptor 3 |
| (3) Threaded Joint | (7) Adaptor 4 |
| (4) Adaptor 1 | (8) Adaptor 5 |

W1024318

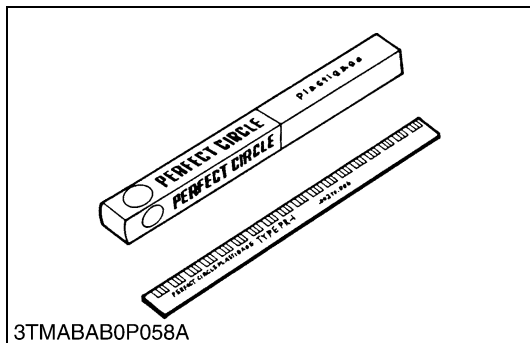

Plastigauge

Code No: 07909-30241
 Application: Use to check the oil clearance between crankshaft and bearing, etc.
 Measuring: Green 0.025 to 0.076 mm (0.001 to 0.003 in.)
 range Red 0.051 to 0.152 mm (0.002 to 0.006 in.)
 Blue 0.102 to 0.229 mm (0.004 to 0.009 in.)

W1024719

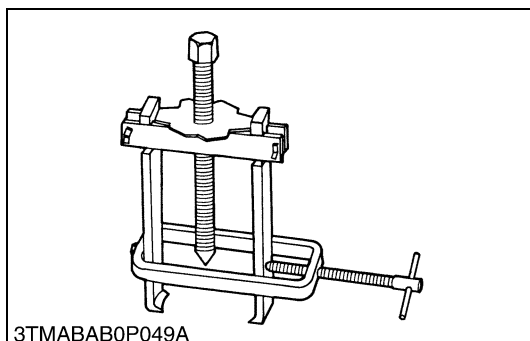

Special Use Puller Set

Code No: 07916-09032
 Application: Use exclusively for pulling out bearing, gears and other parts with ease.

W1024050

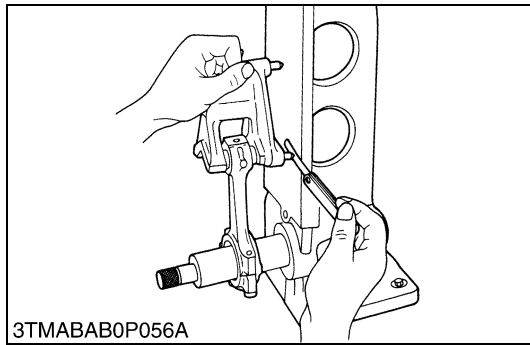

3TMABAB0P056A

Connecting Rod Alignment Tool

Code No: 07909-31661

Application: Use to check the connecting rod alignment.

Applicable: Connecting rod big end I.D.
range 30 to 75 mm (1.18 to 2.95 in.) dia.Connecting rod length
65 to 300 mm (2.56 to 11.81 in.)

W1024583

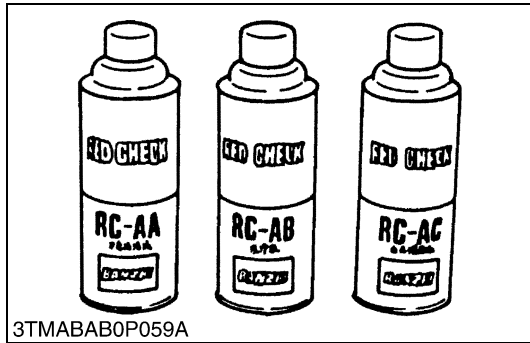

3TMABAB0P059A

Red Check

Code No: 07909-31371

Application: Use to check cracks on cylinder head, cylinder block,
etc.

W1024909

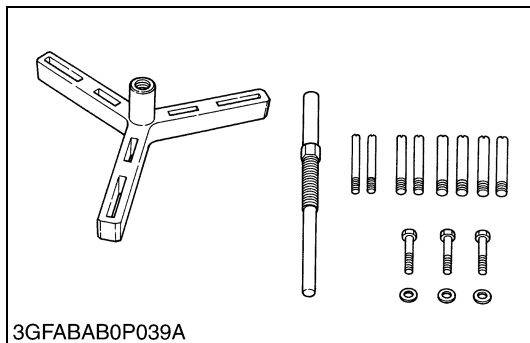

3GFABAB0P039A

Flywheel Puller

Code No: 07916-32011

Application: Use exclusively for removing the flywheel with ease.

W1059257

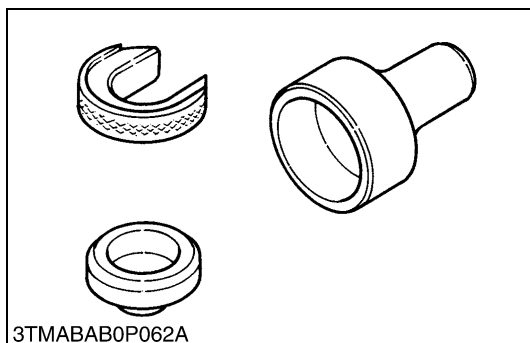

3TMABAB0P062A

Auxiliary Socket for Fixing Crankshaft Sleeve

Code No: 07916-34041

Application: Use exclusively for fixing the crankshaft sleeve.

W1024532

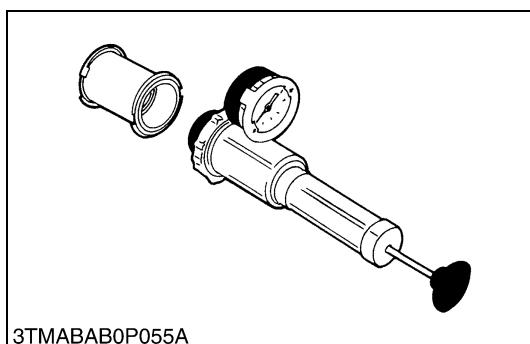

3TMABAB0P055A

Radiator Tester

Code No: 07909-31551

Application: Use to check of radiator cap pressure, and leaks from
cooling system.

Remarks: BANZAI Code No. RCT-2A-30S

W1059359

NOTE

- The following special tools are not provided, so make them referring to the figure.

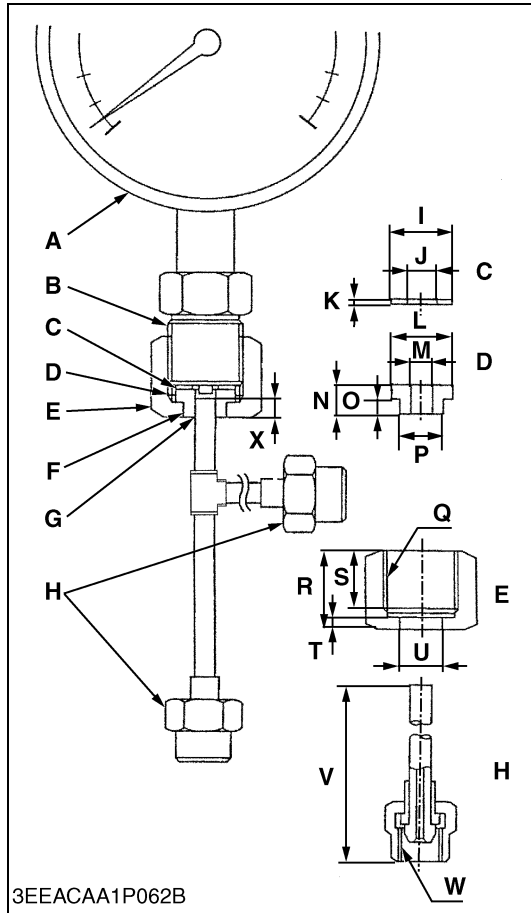

Injection Pump Pressure Tester

Application: Use to check fuel tightness of injection pumps.

A	Pressure gauge full scale : More than 29.4 MPa (300 kgf/cm ² , 4267 psi)
B	PF 1/2
C	Copper gasket
D	Flange (Material : Steel)
E	Hex. nut 27 mm (1.06 in.) across the plat
F	Adhesive application
G	Fillet welding on the enter circumference
H	Retaining nut
I	17 mm dia. (0.67 in. dia.)
J	8 mm dia. (0.31 in. dia.)
K	1.0 mm (0.039 in.)
L	17 mm dia. (0.67 in. dia.)
M	6.10 to 6.20 mm dia. (0.2402 to 0.2441 in. dia.)
N	8 mm (0.31 in.)
O	4 mm (0.16 in.)
P	11.97 to 11.99 mm dia. (0.4713 to 0.4720 in. dia.)
Q	PF 1/2
R	23 mm (0.91 in.)
S	17 mm (0.67 in.)
T	4 mm (0.16 in.)
U	12.00 to 12.02 mm dia. (0.4724 to 0.4732 in. dia.)
V	100 mm (3.94 in.)
W	M12 × P1.5
X	5 mm (0.20 in.)

W10252400

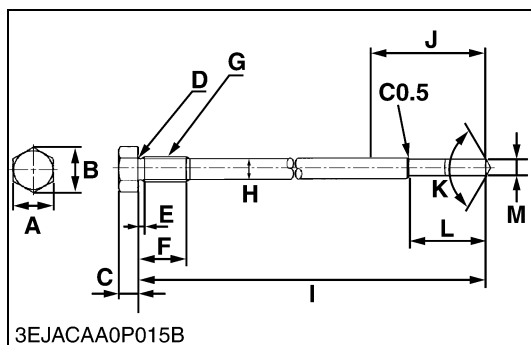

Rotor Pulling Out Bolt (for GL6000, GL7000)

Code No: G3102-10011

Application: Use to remove the rotor assembly.

A	18.65 to 19.0 mm (0.7343 to 0.7480 in.)
B	21.9 mm (0.8622 in.)
C	9 mm (0.3543 in.)
D	1.2 mm (0.0472 in.)
E	3 mm (0.1181 in.)
F	23 mm (0.9055 in.)
G	M12 x 1.25 mm
H	10 mm dia. (0.3937 in. dia.)
I	305 mm (12.0079 in.)
J	55 to 65 mm (2.1654 to 2.5591 in.)
K	2.09 rad (120 °)
L	37 mm (1.4567 in.)
M	7.7 to 8.0 mm dia. (0.3031 to 0.3150 in. dia.)
C0.5	Chamfer 0.5 mm (0.0197 in.)

W1060994

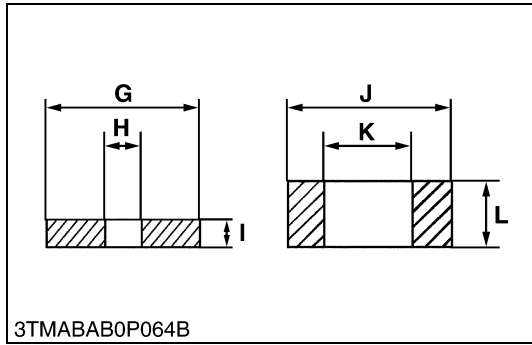
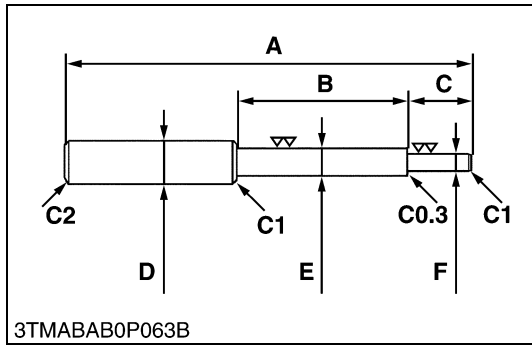

Valve Guide Replacing Tool

Application: Use to press out and press fit the valve guide.

A	200 mm (7.87 in.)
B	80 mm (3.15 in.)
C	40 mm (1.58 in.)
D	20 mm dia. (0.79 in. dia.)
E	9.96 to 9.98 mm dia. (0.3921 to 0.3929 in. dia.)
F	5.5 to 5.7 mm dia. (0.2165 to 0.2244 in. dia.)
G	25 mm (0.98 in.)
H	6.0 to 6.1 mm dia. (0.236 to 0.240 in. dia.)
I	5 mm (0.197 in.)
J	20 mm dia. (0.787 in. dia.)
K	12.5 to 12.8 mm dia. (0.492 to 0.504 in. dia.)
L	8.9 to 9.1 mm (0.350 to 358 in.)
C1	Chamfer 1.0 mm (0.039 in.)
C2	Chamfer 2.0 mm (0.079 in.)
C0.3	Chamfer 0.3 mm (0.012 in.)

W1025017

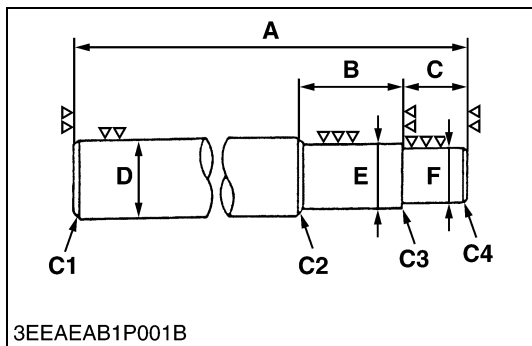

Idle Gear Bushing Replacing Tool

Application: Use to press out and to press fit the idle gear bushing.

A	150 mm (5.91 in.)
B	30 mm (1.18 in.)
C	20 mm (0.79 in.)
D	25 mm dia. (0.98 in. dia.)
E	21.90 to 21.95 mm dia. (0.8622 to 0.8642 in. dia.)
F	19.90 to 19.95 mm dia. (0.7835 to 0.7854 in. dia.)

W1040289

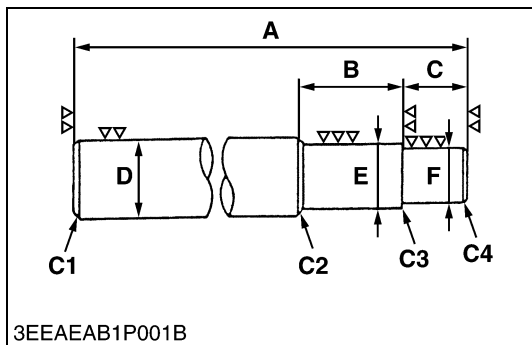

Connecting Rod Small End Bushing Tool

Application : Use to press out and to press fit the connecting rod small end bushing.

A	145 mm (5.71 in.)
B	25 mm (0.98 in.)
C	20 mm (0.79 in.)
D	25 mm dia. (0.98 in. dia.)
E	21.90 to 21.95 mm dia. (0.8622 to 0.8642 in. dia.)
F	19.90 to 19.95 mm dia. (0.7835 to 0.7854 in. dia.)

W1062553

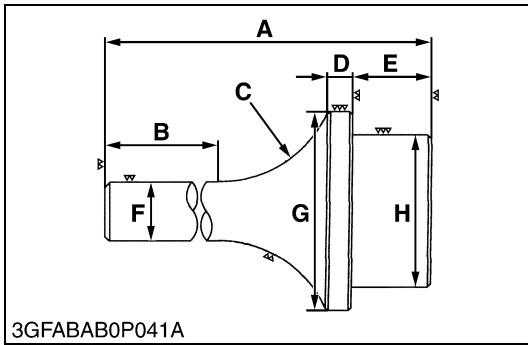

Crankshaft Bearing 1 Replacing Tool

Application: Use to press out and press fit the crankshaft bearing 1.

[Press Out]

A	135 mm (5.31 in.)
B	72 mm (2.83 in.)
C	40 mm radius (1.57 in. radius)
D	10 mm (0.39 in.)
E	22 mm (0.87 in.)
F	20 mm dia. (0.79 in. dia.)
G	47.90 to 47.95 mm dia. (1.8858 to 1.8878 in. dia.)
H	43.90 to 43.95 mm dia. (1.7283 to 1.7303 in. dia.)

[Press Fit]

A	130 mm (5.12 in.)
B	72 mm (2.83 in.)
C	40 mm radius (1.57 in. radius)
D	9 mm (0.35 in.)
E	24 mm (0.95 in.)
F	20 mm dia. (0.79 in. dia.)
G	68 mm dia. (2.68 in. dia.)
H	43.90 to 43.95 mm dia. (1.7283 to 1.7303 in. dia.)

W1026139

MECHANISM

CONTENTS

1. ENGINE BODY	1-M1
[1] HALF-FLOATING HEAD COVER	1-M1
2. LUBRICATING SYSTEM	1-M2
3. COOLING SYSTEM	1-M3
4. FUEL SYSTEM	1-M4

1. ENGINE BODY

[1] HALF-FLOATING HEAD COVER

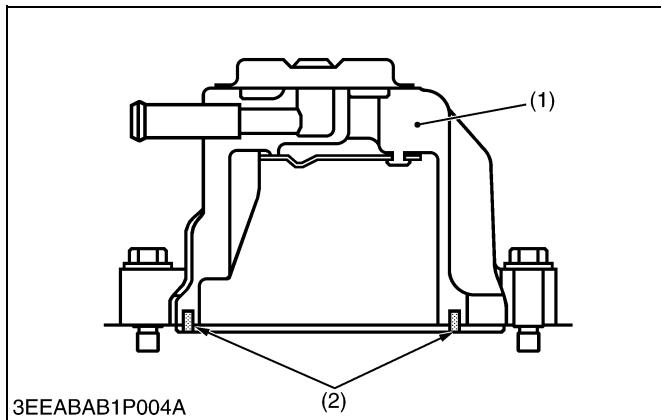
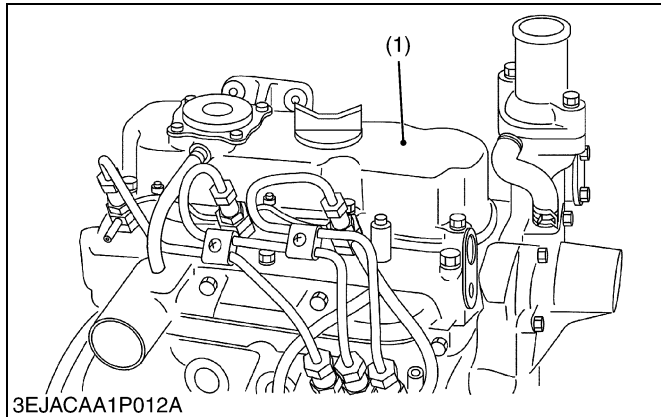

The rubber packing is fitted in to maintain the head cover 0.5 mm or so off the cylinder head. This arrangement helps reduce noise coming from the cylinder head.

(1) Cylinder Head Cover (2) Rubber Packing

W1013396

2. LUBRICATING SYSTEM

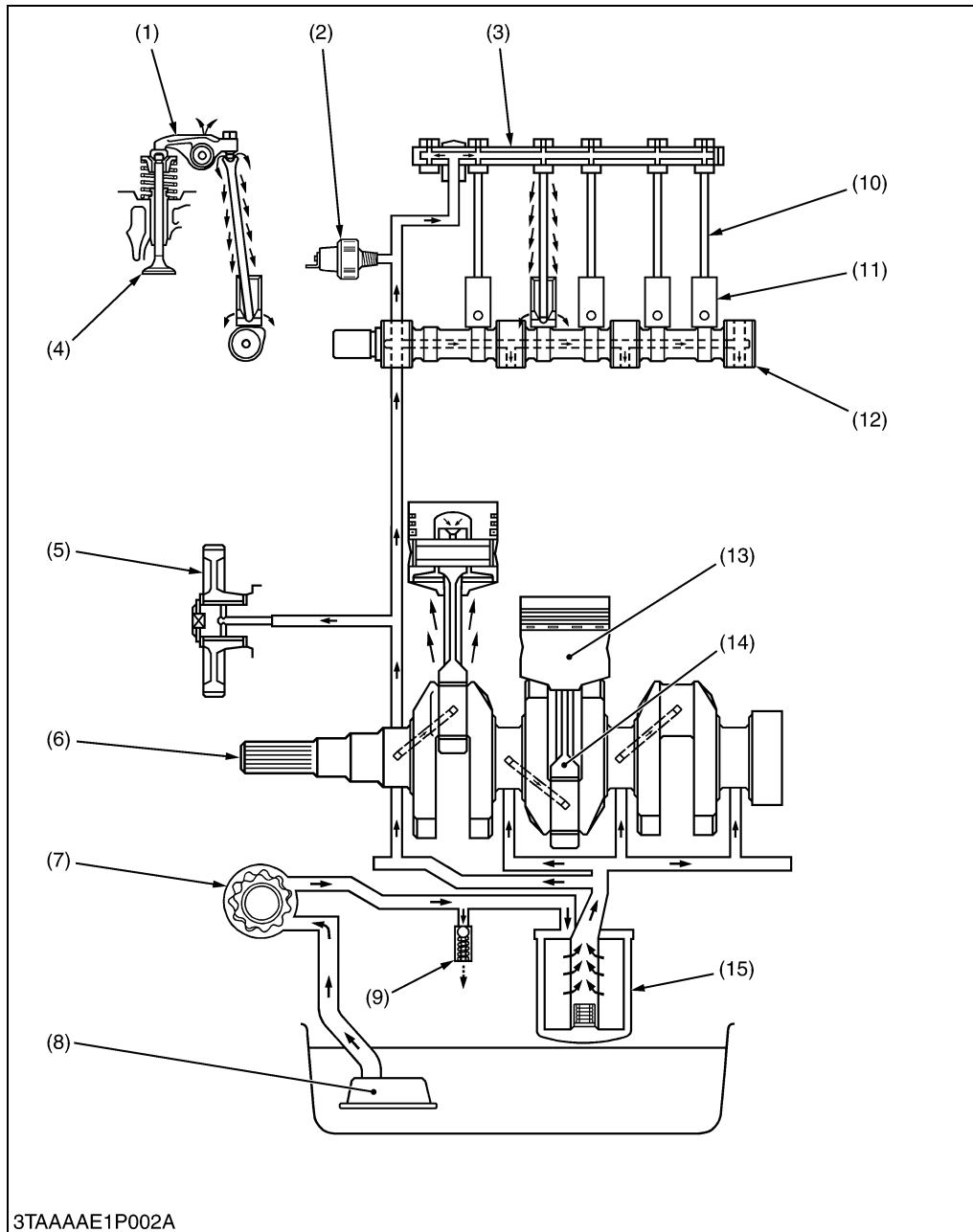

- (1) Rocker Arm
- (2) Oil Pressure Switch
- (3) Rocker Arm Shaft
- (4) Valve
- (5) Idle Gear
- (6) Crankshaft
- (7) Oil Pump
- (8) Oil Strainer
- (9) Relief Valve
- (10) Push Rod
- (11) Tappet
- (12) Camshaft
- (13) Piston
- (14) Connecting Rod
- (15) Oil Filter Cartridge

W1014160

This engine's lubricating system consists of oil strainer (8), oil pump (7), relief valve (9), oil filter cartridge (15) and oil pressure switch (2).

The oil pump sucks lubricating oil from the oil pan through the oil strainer and the oil flows down to the filter cartridge, where it is further filtered. Then the oil is forced to crankshaft (6), connecting rods (14), idle gear (5), camshaft (12) and rocker arm shaft (3) to lubricate each part.

Some part of oil, splashed by the crankshaft or leaking and dropping from gaps of each part, lubricates these parts: piston (13), cylinders, small ends or connecting rods, tappets (11), push rods (10), inlet and exhaust valves (4) and timing gears.

3. COOLING SYSTEM

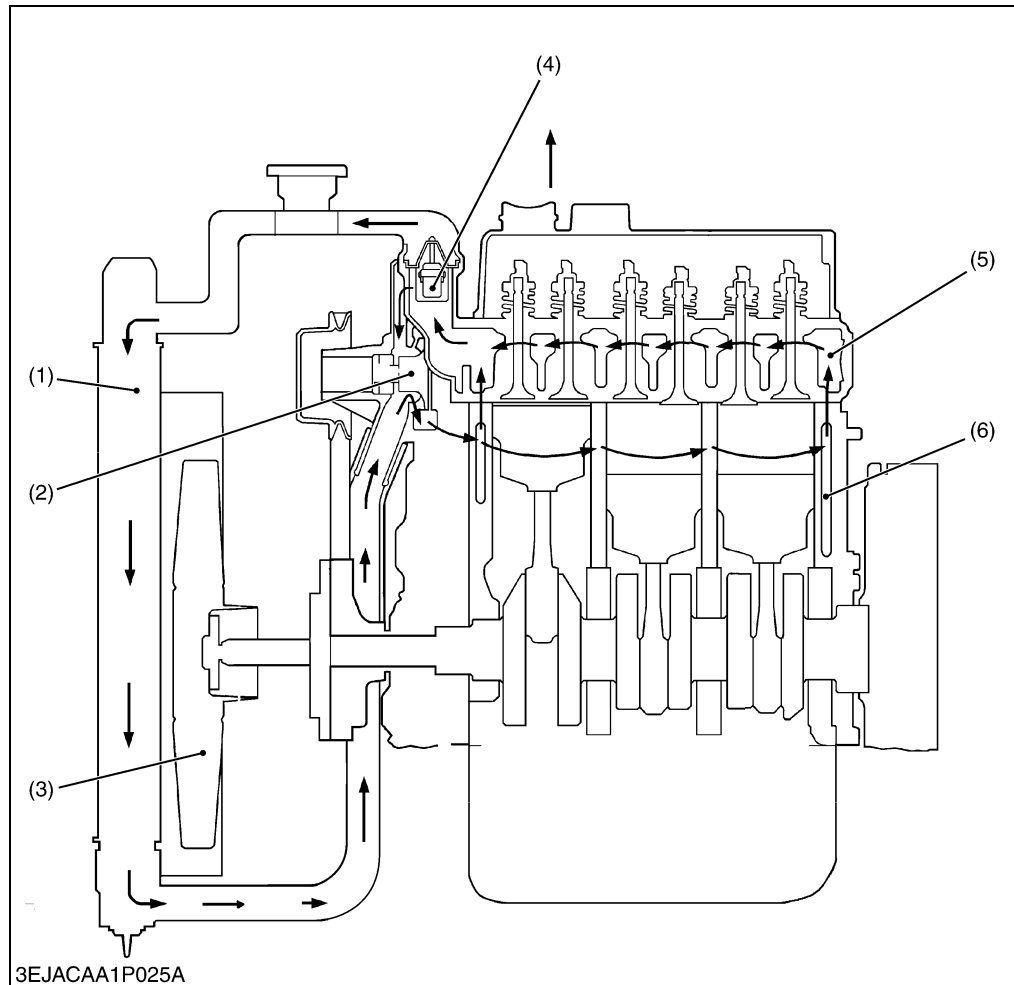

- (1) Radiator
- (2) Water Pump
- (3) Cooling Fan
- (4) Thermostat
- (5) Cylinder Head
- (6) Cylinder Block

3EJACAA1P025A

The cooling system consists of a radiator (1), a centrifugal water pump (2), a cooling fan (3) and a thermostat (4). The cooling fan (3) pushes air through the radiator core to carry away heat stored in the coolant.

The water pump receives water from the radiator or from the cylinder head and force it into the cylinder block.

The thermostat opens or closes according to the water temperature. When the water temperature is high, the thermostat opens to allow the water to flow from the cylinder head to the radiator. When the water temperature is low, the thermostat close to flow the water only to the water pump.

4. FUEL SYSTEM

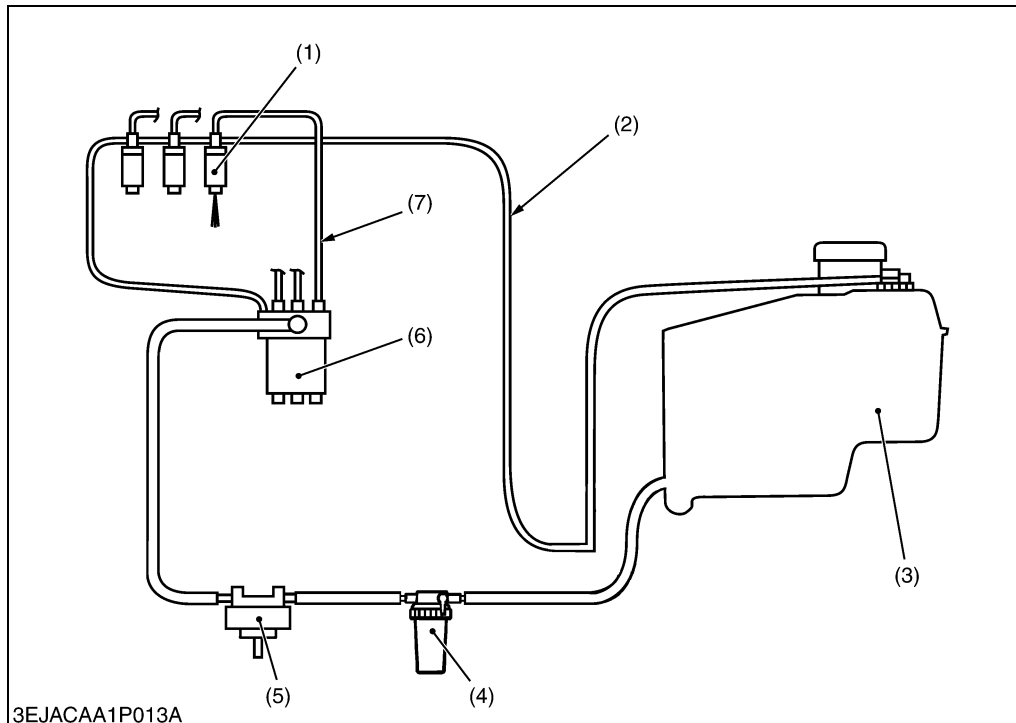

- (1) Injection Nozzle
- (2) Fuel Overflow Pipe
- (3) Fuel Tank
- (4) Fuel Filter
- (5) Mechanical Fuel Feed Pump
- (6) Injection Pump
- (7) Injection Pipe

3EJACAA1P013A

Fuel from the fuel tank (3) passes through the fuel filter (4), and then enters the injection pump (6) after impurities such as dirt, water, etc. are removed.

The fuel pressurized by the injection pump to the opening pressure (13.73 to 14.71 MPa, 140 to 150 kgf/cm², 1990 to 2133 psi), of the injection nozzle (1) is injected into the combustion chamber.

Part of the fuel fed to the injection nozzle (1) lubricates the moving parts of the needle valve inside the nozzle, then returns to the fuel tank through the fuel overflow pipe (2) from the upper part of the nozzle holder.

SERVICING

CONTENTS

1. TROUBLESHOOTING	1-S1
2. SERVICING SPECIFICATIONS	1-S4
3. TIGHTENING TORQUES	1-S10
[1] TIGHTENING TORQUES FOR SPECIAL USE SCREWS, BOLT AND NUTS.....	1-S10
[2] TIGHTENING TORQUES FOR GENERAL USE SCREWS, BOLTS AND NUTS.....	1-S11
4. CHECKING, DISASSEMBLING AND SERVICING.....	1-S12
[1] CHECKING AND ADJUSTING	1-S12
(1) Engine Body.....	1-S12
(2) Lubricating System	1-S15
(3) Cooling System.....	1-S16
(4) Fuel System	1-S18
(5) Electrical System	1-S21
[2] PREPARATION	1-S25
(1) Separating Engine	1-S25
[3] DISASSEMBLING AND ASSEMBLING.....	1-S28
(1) Cylinder Head and Valves	1-S28
(2) Timing Gears, Camshaft, Fuel Camshaft and Oil Pan	1-S32
(3) Piston and Connecting Rod	1-S36
(4) Crankshaft.....	1-S38
(5) Water Pump.....	1-S40
(6) Injection Nozzle.....	1-S40
(7) Starter	1-S41
[4] SERVICING	1-S43
(1) Cylinder Head and Valves	1-S43
(2) Timing Gears, Camshaft and Fuel Camshaft.....	1-S48
(3) Piston and Connecting Rod	1-S51
(4) Crankshaft.....	1-S53
(5) Cylinder.....	1-S57
(6) Oil Pump	1-S58
(7) Starter	1-S59

1. TROUBLESHOOTING

Symptom	Probable Cause	Solution	Reference Page
Engine Does Not Start	Terminal cover is open	Close terminal cover	–
	No fuel	Fill fuel	–
	Air in the fuel system	Bleed	–
	Water in the fuel system	Change fuel and repair or replace fuel system	–
	Fuel hose clogged	Clean	–
	Fuel filter clogged	Change	G-19
	Excessively high viscosity of fuel or engine oil at low temperature	Use specified fuel or engine oil	G-9
	Fuel with low cetane number	Use specified fuel	G-9
	Fuel leak due to loose injection pipe retaining nut	Tighten retaining nut	1-S28
	Incorrect injection timing	Adjust	1-S18
	Fuel camshaft worn	Replace	1-S49
	Injection nozzle clogged	Clean or replace	1-S20
	Injection pump malfunctioning	Replace	1-S19, S32
	Seizure of crankshaft, camshaft, piston, cylinder or bearing	Repair or replace	1-S36 to S39 1-S52 to S57
	Compression leak from cylinder	Replace head gasket, tighten cylinder head screw, glow plug and nozzle holder	1-S12, 31
	Improper valve timing	Correct or replace timing gear	G-22
	Piston ring and cylinder worn	Replace	1-S52, S57
Excessive valve clearance	Adjust	G-22	
(Starter Does Not Run)	Battery discharged	Charge	G-17, 1-S21
	Starter malfunctioning	Repair or replace	1-S41, S59 to 60
	Wiring disconnected	Connect	–
Engine Revolution Is Not Smooth	Fuel filter clogged or dirty	Replace	G-19
	Air cleaner clogged	Clean or replace	G-17, 24
	Fuel leak due to loose injection pipe retaining nut	Tighten retaining nut	1-S28
	Injection pump malfunctioning	Replace	1-S19
	Incorrect nozzle injection pressure	Adjust	1-S20
	Injection nozzle stuck or clogged	Repair or replace	1-S20
	Governor malfunctioning	Repair	1-S34

W1014322

Symptom	Probable Cause	Solution	Reference Page
Either White or Blue Exhaust Gas Is Observed	Excessive engine oil	Reduce to specified level	G-9, 14
	Piston ring and cylinder worn or stuck	Repair or replace	1-S52, S57
	Incorrect injection timing	Adjust	1-S18
	Deficient compression	Adjust top clearance	1-S12
Either Black or Dark Gray Exhaust Gas Is Observed	Overload	Reduce the load	–
	Low grade fuel used	Use specified fuel	G-9
	Fuel filter clogged	Replace	G-18
	Air cleaner clogged	Clean or replace	G-17, 24
	Deficient nozzle injection	Repair or replace nozzle	G-23
Deficient Output	Incorrect injection timing	Adjust	1-S18
	Engine's moving parts seem to be seizing	Repair or replace	–
	Uneven fuel injection	Replace injection pump	1-S20
	Deficient nozzle injection	Repair or replace nozzle	1-S20
	Compression leak	Replace head gasket, tighten cylinder head screw, glow plug and nozzle holder	1-S12
Excessive Lubricant Oil Consumption	Piston ring's gap facing the same direction	Shift ring gap direction	1-S36
	Oil ring worn or stuck	Replace	1-S52
	Piston ring groove worn	Replace piston	1-S52
	Valve stem and valve guide worn	Replace	1-S44
	Oil leaking due to defective seals or packing	Replace	–
Fuel Mixed into Lubricant Oil	Injection pump's plunger worn	Replace injection pump	1-S19
	Deficient nozzle injection	Repair or replace nozzle	1-S20
	Injection pump broken	Replace	1-S19
Water Mixed into Lubricant Oil	Head gasket defective	Replace	1-S31
	Cylinder block or cylinder head flawed	Replace	1-S43

W1014322

Symptom	Probable Cause	Solution	Reference Page
Low Oil Pressure	Engine oil insufficient	Fill oil	G-9, 14
	Oil strainer clogged	Clean	1-S35
	Oil filter cartridge clogged	Replace	–
	Relief valve stuck with dirt	Clean	–
	Relief valve spring weaken or broken	Replace	–
	Excessive oil clearance of crankshaft bearing	Replace	1-S54 to S56
	Excessive oil clearance of crankpin bearing	Replace	1-S54
	Excessive oil clearance of rocker arm	Replace	1-S47
	Oil passage clogged	Clean	1-M2
	Different type of oil	Use specified type of oil	G-9
	Oil pump defective	Repair or replace	1-S34, S58
High Oil Pressure	Different type of oil	Use specified type of oil	G-9
	Relief valve defective	Replace	–
Engine Overheated	Engine oil insufficient	Fill oil	G-9, 14
	Fan belt broken or tensioned improperly	Replace or adjust	G-17
	Coolant insufficient	Fill coolant	G-14, 20
	Radiator net and radiator fin clogged with dust	Clean	–
	Inside of radiator corroded	Clean or replace	G-20
	Coolant flow route corroded	Clean or replace	G-20
	Radiator cap defective	Replace	–
	Radiator hose damaged	Replace	–
	Overload running	Reduce the load	–
	Head gasket defective	Replace	1-S31
	Incorrect injection timing	Adjust	1-S18
	Unsuitable fuel used	Use specified fuel	G-9

W1014322

2. SERVICING SPECIFICATIONS

ENGINE BODY

Item		Factory Specification	Allowable Limit
Cylinder Head Surface	Flatness	–	0.05 mm 0.0020 in.
Top Clearance		0.50 to 0.70 mm 0.0197 to 0.0276 in.	–
Compression Pressure	–	2.84 to 3.24 MPa 29.0 to 33.0 kgf/cm ² 412 to 469 psi	2.26 MPa 23.0 kgf/cm ² 327 psi
	Variance among cylinder	–	10 % or less
Valve Clearance (Cold)		0.145 to 0.185 mm 0.00571 to 0.00728 in.	–
Valve Seat	Angle	0.785 rad 45 °	–
	Width	2.12 mm 0.0835 in.	–
Valve Stem to Valve Guide	Clearance	0.030 to 0.057 mm 0.00118 to 0.00224 in.	0.10 mm 0.0039 in.
Valve Stem	O.D.	5.968 to 5.980 mm 0.23496 to 0.23543 in.	–
Valve Guide	I.D.	6.010 to 6.025 mm 0.23661 to 0.23720 in.	–
Valve Seat	Angle	0.785 rad 45 °	–
	Width	2.12 mm 0.0835 in.	–
Valve Face	Angle	0.785 rad 45 °	–
Valve Recessing (Intake and Exhaust)		–0.10 to 0.10 mm –0.0039 to 0.0039 in.	0.30 mm 0.0118 in.
Valve Timing (Intake Valve)	Open	0.35 rad 20 ° before T.D.C.	–
	Close	0.79 rad 45 ° after B.D.C.	–
Valve Timing (Exhaust Valve)	Open	0.87 rad 50 ° before B.D.C.	–
	Close	0.26 rad 15 ° after T.D.C.	–

ENGINE BODY (Continued)

Item		Factory Specification	Allowable Limit
Valve Spring	Free Length	31.3 to 31.8 mm 1.232 to 1.252 in.	28.4 mm 1.118 in.
	Tilt	–	1.2 mm 0.047 in.
	Setting Load / Setting Length	64.7 N / 27.0 mm 6.6 kgf / 27.0 mm 14.6 lbf / 1.063 in.	54.9 N / 27.0 mm 5.6 kgf / 27.0 mm 12.3 lbf / 1.063 in.
Rocker Arm Shaft to Rocker Arm	Oil Clearance	0.016 to 0.045 mm 0.00063 to 0.00177 in.	0.15 mm 0.0059 in.
Rocker Arm Shaft	O.D.	10.473 to 10.484 mm 0.41232 to 0.41276 in.	–
Rocker Arm	I.D.	10.500 to 10.518 mm 0.41339 to 0.41410 in.	–
Push Rod	Alignment	–	0.25 mm 0.0098 in.
Tappet to Tappet Guide Bore	Oil Clearance	0.016 to 0.052 mm 0.00063 to 0.00205 in.	0.10 mm 0.0039 in.
Tappet	O.D.	17.966 to 17.984 mm 0.70732 to 0.70803 in.	–
Tappet Guide Bore	I.D.	18.000 to 18.018 mm 0.70866 to 0.70937 in.	–
Camshaft	Side Clearance	0.15 to 0.31 mm 0.0059 to 0.0122 in.	0.50 mm 0.0197 in.
Cam Height	Alignment	–	0.01 mm 0.0004 in.
	Intake and Exhaust	26.88 mm 1.0583 in.	26.83 mm 1.0563 in.
Camshaft Journal to Cylinder Block Bore	Oil Clearance	0.050 to 0.091 mm 0.00197 to 0.00358 in.	0.15 mm 0.0059 in.
Camshaft Journal	O.D.	32.934 to 32.950 mm 1.29661 to 1.29724 in.	–
Cylinder Block Bore	I.D.	33.000 to 33.025 mm 1.29921 to 1.30020 in.	–

ENGINE BODY (Continued)

Item		Factory Specification	Allowable Limit
Timing Gear	Crank Gear to Idle Gear	Backlash 0.043 to 0.124 mm 0.00169 to 0.00488 in.	0.15 mm 0.0059 in.
	Idle Gear to Cam Gear	Backlash 0.047 to 0.123 mm 0.00185 to 0.00484 in.	0.15 mm 0.0059 in.
	Idle Gear to Injection Pump Gear	Backlash 0.046 to 0.124 mm 0.00181 to 0.00488 in.	0.15 mm 0.0059 in.
	Crank Gear to Oil Pump Drive Gear	Backlash 0.041 to 0.123 mm 0.00161 to 0.00484 in.	0.15 mm 0.0059 in.
Idle Gear	Side Clearance	0.20 to 0.46 mm 0.0079 to 0.0180 in.	0.60 mm 0.0236 in.
Idle Gear Shaft to Idle Gear Bushing	Oil Clearance	0.020 to 0.084 mm 0.00079 to 0.00331 in.	0.10 mm 0.0039 in.
	Idle Gear Shaft	O.D. 19.967 to 19.980 mm 0.78610 to 0.78661 in.	–
	Idle Gear Bushing	I.D. 20.000 to 20.051 mm 0.78740 to 0.78941 in.	–
Piston Pin Bore	I.D.	20.000 to 20.013 mm 0.78740 to 0.78791 in.	20.05 mm 0.7894 in.
Piston Ring Clearance	Second Ring	Clearance 0.90 to 0.120 mm 0.00354 to 0.00472 in.	0.15 mm 0.0059 in.
	Oil Ring	Clearance 0.04 to 0.08 mm 0.0016 to 0.0031 in.	0.15 mm 0.0059 in.
Piston Ring Gap	Top Ring	Clearance 0.15 to 0.30 mm 0.0059 to 0.0118 in.	1.20 mm 0.0472 in.
	Second Ring	Clearance 0.30 to 0.45 mm 0.00118 to 0.0177 in.	1.20 mm 0.0472 in.
	Oil Ring	Clearance 0.15 to 0.30 mm 0.0059 to 0.0118 in.	1.20 mm 0.0472 in.
Connecting Rod	Alignment	–	0.05 mm 0.0020 in.
Piston Pin to Small End Bushing	Oil Clearance	0.014 to 0.038 mm 0.00055 to 0.00150 in.	0.10 mm 0.0039 in.
	Piston Pin	O.D. 20.002 to 20.011 mm 0.78748 to 0.78783 in.	–
	Small End Bushing	I.D. 20.025 to 20.040 mm 0.78839 to 0.78897 in.	–

ENGINE BODY (Continued)

Item		Factory Specification	Allowable Limit
Crankshaft	Alignment	–	0.02 mm 0.0008 in.
Crankshaft Journal to Crankshaft Bearing 1	Oil Clearance	0.034 to 0.106 mm 0.00134 to 0.00417 in.	0.20 mm 0.0079 in.
Crankshaft Journal	O.D.	39.934 to 39.950 mm 1.57221 to 1.57284 in.	–
Crankshaft Bearing 1	I.D.	39.984 to 40.040 mm 1.57417 to 1.57638 in.	–
Crankshaft Journal to Crankshaft Bearing 2 (Flywheel Side)	Oil Clearance	0.028 to 0.059 mm 0.00110 to 0.00232 in.	0.20 mm 0.0079 in.
Crankshaft Journal	O.D.	43.934 to 43.950 mm 1.72968 to 1.73031 in.	–
Crankshaft Bearing 2	I.D.	43.978 to 43.993 mm 1.73142 to 1.73201 in.	–
Crankshaft Journal to Crankshaft Bearing 3 (Intermediate)	Oil Clearance	0.028 to 0.059 mm 0.00110 to 0.00232 in.	0.20 mm 0.0079 in.
Crankshaft Journal	O.D.	43.934 to 43.950 mm 1.72968 to 1.73031 in.	–
Crankshaft Bearing 3	I.D.	43.978 to 43.993 mm 1.73142 to 1.73201 in.	–
Crankpin to Crankpin Bearing	Oil Clearance	0.020 to 0.051 mm 0.00079 to 0.00201 in.	0.15 mm 0.0059 in.
Crankpin	O.D.	33.959 to 33.975 mm 1.33697 to 1.33760 in.	–
Crankpin Bearing	I.D.	33.995 to 34.010 mm 1.33893 to 1.33898 in.	–
Crankshaft	Side Clearance	0.15 to 0.31 mm 0.0059 to 0.0122 in.	0.50 mm 0.0197 in.
Cylinder Liner [Standard]	I.D.	67.000 to 67.019 mm 2.63780 to 2.63854 in.	67.169 mm 2.64445 in.
Cylinder Liner [Oversize : 0.25 mm (0.0098 in.)]	I.D.	67.250 to 67.269 mm 2.64764 to 2.64839 in.	67.419 mm 2.65429 in.

W11149370

LUBRICATING SYSTEM

Item		Factory Specification	Allowable Limit
Engine Oil Pressure	At Idle Speed	More than 49 kPa 0.5 kgf/cm ² 7 psi	–
	At Rated Speed	196 to 441 kPa 2.0 to 4.5 kgf/cm ² 28 to 64 psi	147 kPa 1.5 kgf/cm ² 21 psi
Inner Rotor to Outer Rotor	Clearance	0.03 to 0.14 mm 0.0012 to 0.0055 in.	–
Outer Rotor to Pump Body	Clearance	0.07 to 0.15 mm 0.0028 to 0.0059 in.	–
Inner Rotor to Cover	Clearance	0.075 to 0.135 mm 0.00295 to 0.00531 in.	–

W10139730

COOLING SYSTEM

Fan Belt	Tension	7.0 to 9.0 mm / 98 N 0.28 to 0.35 in. / 98 N (10 kgf, 22 lbf)	–
Thermostat	Valve Opening Temperature (At Beginning)	69.5 to 72.5 °C 157.1 to 162.5 °F	–
	Valve Opening Temperature (Opened Completely)	85 °C 185 °F	–
Radiator Cap	Pressure Falling Time	10 seconds or more 88 → 59 kPa 0.9 → 0.6 kgf/cm ² 13 → 9 psi	–
Radiator	Water Leakage Test Pressure	No leak at specified pressure 157 kPa 1.6 kgf/cm ² 23 psi	–

W10135990

FUEL SYSTEM

Item		Factory Specification	Allowable Limit
Injection Pump		0.33 to 0.37 rad (19 to 21 °) before T.D.C.	–
Pump Element	Fuel Tightness	–	13.73 MPa 140 kgf/cm ² 1991 psi
Delivery Valve	Fuel Tightness	10 seconds 13.73 → 12.75 MPa 140 → 130 kgf/cm ² 1991 → 1849 psi	5 seconds 13.73 → 12.75 MPa 140 → 130 kgf/cm ² 1991 → 1849 psi
Injection Nozzle	Injection Pressure	When the pressure is 12.75 kPa (130 kgf/cm ² 1849 psi), the valve seat must be fuel tightness	–

W10139730

ELECTRICAL SYSTEM**[STARTER]**

Starter (Electromagnetic Drive Type)	Commutator	O.D.	28.0 mm 1.102 in.	27.0 mm 1.063 in.
	Difference	O.D.	Less than 0.05 mm 0.0002 in.	0.4 mm 0.016 in.
	Mica	Undercut	0.50 to 0.80 mm 0.0197 to 0.0315 in.	0.20 mm 0.0079 in.
	Brush	Length	16.0 mm 0.630 in.	10.5 mm 0.413 in.
Starter (Planetary Gear Reduction Type)	Commutator	O.D.	30.0 mm 1.181 in.	29.0 mm 1.142 in.
	Difference	O.D.	Less than 0.02 mm 0.0008 in.	0.5 mm 0.020 in.
	Mica	Undercut	0.50 to 0.80 mm 0.0197 to 0.0315 in.	0.20 mm 0.0079 in.
	Brush	Length	14.0 mm 0.551 in.	9.0 mm 0.354 in.

W10336330

3. TIGHTENING TORQUES

Screws, bolts and nuts must be tightened to the specified torque using a torque wrench, several screws, bolts and nuts such as those used on the cylinder head must be tightened in proper sequence and the proper torque.

[1] TIGHTENING TORQUES FOR SPECIAL USE SCREWS, BOLT AND NUTS

■ NOTE

- For “*” marked screws, bolts and nuts on the table, apply engine oil to their threads and seats before tightening.
- The letter “M” in Size x Pitch means that the screw, bolt or nut dimension stands for metric. The size is the nominal outside diameter in mm of the threads. The pitch is the nominal distance in mm between two threads.

Item	Size x Pitch	N·m	kgf·m	lbf·ft
Cylinder head cover screw	M6 x 1	6.86 to 11.3	0.7 to 1.15	5.1 to 8.3
Injection pipe retaining nut	M12 x 1.5	24.5 to 34.3	2.5 to 3.5	18.1 to 25.3
Overflow pipe retaining nut	M12 x 1.5	19.6 to 24.5	2.0 to 2.5	14.5 to 18.1
Nozzle holder assembly	M20 x 1.5	49.0 to 68.6	5.0 to 7.0	36.2 to 50.6
Glow plug	M8 x 1	7.85 to 14.7	0.8 to 1.5	5.8 to 10.8
*Rocker arm bracket screw	M6 x 1	9.8 to 11.3	1.00 to 1.15	7.2 to 8.3
*Cylinder head screw	M8 x 1.25	37.3 to 42.2	3.8 to 4.3	27.5 to 31.1
*Fan drive pulley screw	M12 x 1.5	98.1 to 107.9	10.0 to 11.0	72.3 to 79.6
*Idle gear shaft mounting screw	M6 x 1	9.8 to 11.3	1.00 to 1.15	7.2 to 8.3
*Connecting rod screw	M7 x 0.75	26.5 to 30.4	2.7 to 3.1	19.5 to 22.4
*Flywheel screw	M10 x 1.25	53.9 to 58.8	5.5 to 6.0	39.8 to 43.4
Bearing case cover mounting screw	M6 x 1	9.8 to 11.3	1.00 to 1.15	7.2 to 8.3
*Main bearing case screw 2	M7 x 1	26.5 to 30.4	2.7 to 3.1	19.5 to 22.4
*Main bearing case screw 1	M6 x 1	12.7 to 15.7	1.3 to 1.6	9.4 to 11.6
Nozzle holder	–	34.3 to 39.2	3.5 to 4.0	25.3 to 28.9
Oil pressure switch	PT 1/8	14.7 to 19.6	1.5 to 2.0	10.8 to 14.5
Starter's terminal B mounting nut (Electromagnetic drive type)	M8	7.8 to 9.8	0.8 to 1.0	5.8 to 7.2
Starter's terminal B mounting nut (Planetary gear reduction type)	M8	5.9 to 11.8	0.6 to 1.2	4.3 to 8.7

W1013236

[2] TIGHTENING TORQUES FOR GENERAL USE SCREWS, BOLTS AND NUTS

When the tightening torques are not specified, tighten the screws, bolts and nuts according to the table below.

Grade Nominal Diameter	Unit	Standard Screw and Bolt ④			Special Screw and Bolt ⑦		
		N·m	kgf·m	lbf·ft	N·m	kgf·m	lbf·ft
M6		7.9 to 9.3	0.80 to 0.95	5.8 to 6.9	9.8 to 11.3	1.00 to 1.15	7.23 to 8.32
M8		17.7 to 20.6	1.8 to 2.1	13.0 to 15.2	23.5 to 27.5	2.4 to 2.8	17.4 to 20.3
M10		39.2 to 45.1	4.0 to 4.6	28.9 to 33.3	48.1 to 55.9	4.9 to 5.7	35.4 to 41.2
M12		62.8 to 72.6	6.4 to 7.4	46.3 to 53.5	77.5 to 90.2	7.9 to 9.2	57.1 to 66.5

W10371750

Screw and bolt material grades are shown by numbers punched on the screw and bolt heads. Prior to tightening, be sure to check out the numbers as shown below.

Punched number	Screw and bolt material grade
None or 4	Standard screw and bolt SS41, S20C
7	Special screw and bolt S43C, S48C (Refined)

W1012705

4. CHECKING, DISASSEMBLING AND SERVICING

[1] CHECKING AND ADJUSTING

(1) Engine Body

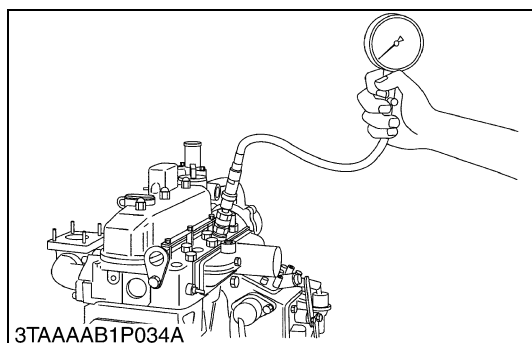

Compression Pressure

1. After warming up the engine, stop it and remove the air cleaner, the muffler and all nozzle holders.
2. Install a compression tester for diesel engines to nozzle holder hole.
3. After making sure that the speed control lever is set at the stop position (Non-injection), run the engine at 3.3 to 5.0 1/s (200 to 300 rpm) with the starter.
4. Read the maximum pressure. Measure the pressure more than twice.
5. If the measurement is below the allowable limit, check the cylinder, piston ring, top clearance, valve and cylinder head.
6. If the measurement is below the allowable limit, apply a small amount of oil to the cylinder wall through the nozzle hole and measure the compression pressure again.
7. If the compression pressure is still less than the allowable limit, check the top clearance, valve clearance and cylinder head.
8. If the compression pressure increases after applying oil, check the cylinder wall and piston rings.

■ NOTE

- Check the compression pressure with the specified valve clearance.
- Always use a fully charged battery for performing this test.
- Variances in cylinder compression values should be under 10 %.

Compression pressure	Factory spec.	2.84 to 3.24 MPa 29.0 to 33.0 kgf/cm ² 412 to 469 psi
	Allowable limit	2.26 MPa 23.0 kgf/cm ² 327 psi

W10178940

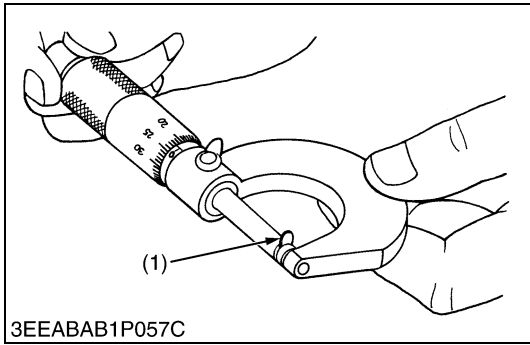
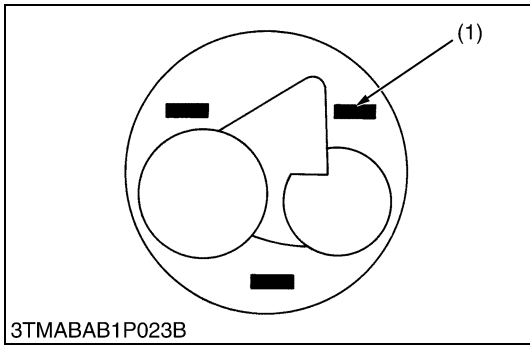

Top Clearance

1. Remove the cylinder head. (Do not attempt to remove the cylinder head gasket.)
2. Move the piston up, and stick a strip of fuse [1.5 mm dia. (0.059 in. dia.), 5 to 7 mm long (0.197 to 0.276 in. long)] on the piston head at three positions with grease so as to avoid the intake and exhaust valves and the combustion chamber ports.
3. Lower the piston, and install the cylinder head and tighten the cylinder head screws to the specified torque.
4. Turn the flywheel until the piston exceeds its top dead center.
5. Remove the cylinder head, and measure the thickness of the squeezed fuses.
6. If the measurement is not within the factory specifications, check the oil clearance between the crankpin and crankpin bearing and between the piston pin and small end bushing.

NOTE

- **After checking the top clearance, be sure to assemble the cylinder head with a new cylinder head gasket.**

Top clearance	Factory spec.	0.50 to 0.70 mm 0.0197 to 0.0276 in.
Tightening torque	Cylinder head screw	37.3 to 42.2 N·m 3.8 to 4.3 kgf·m 27.5 to 31.1 lbf·ft

(1) Fuse

W10389120

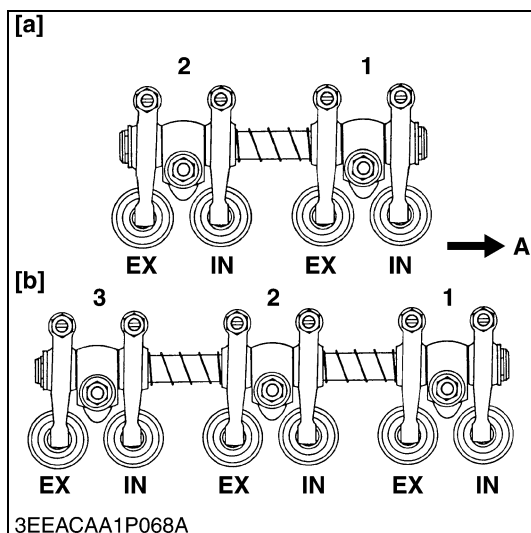
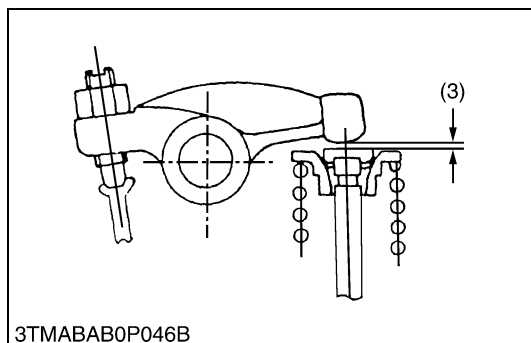
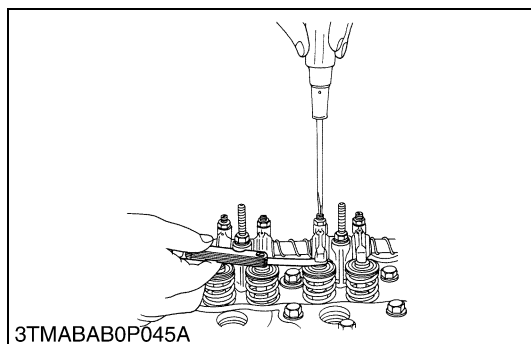
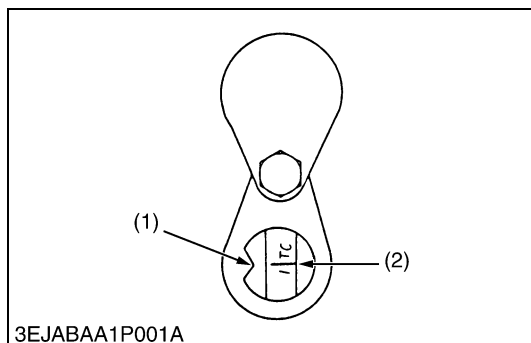

Valve Clearance

■ IMPORTANT

- The valve clearance must be checked and adjusted when engine is cold.
1. Remove the head cover, the glow plugs and the timing window cover on the flywheel housing.
 2. Align the **1TC** mark line (2) on the flywheel and center of timing window (1) so that the No. 1 piston comes to the compression or overlap top dead center.
 3. Check the following valve clearance marked with "☆" using a feeler gauge.
 4. If the clearance is not within the factory specifications, adjust with the adjusting screw.

Intake and exhaust valve clearance (Cold)	Factory spec.	0.145 to 0.185 mm 0.00571 to 0.00728 in.
---	---------------	---

■ NOTE

- The "TC" marking line on the flywheel is just for No. 1 cylinder. There is no TC marking for the other cylinders.
- No. 1 piston comes to the top dead center position when the TC marking is aligned with center of timing window on flywheel-housing. Turn the flywheel 0.26 rad (15 °) clockwise and counterclockwise to see if the piston is at the compression top dead center or the overlap position. Now referring to the table below, readjust the valve clearance. (The piston is at the compression top dead center when both the IN. and EX. valves do not move; it is at the overlap position when both the valves move.)
- Finally turn the flywheel 6.28 rad (360 °) and align the TC marking line and the center of timing window. Adjust all the other valve clearance as required.
- After turning the flywheel counterclockwise twice or three times, recheck the valve clearance, firmly tighten the lock nut of the adjusting screw.
- The sequence of cylinder numbers is given as No. 1, No. 2 and No. 3 starting from the gear case side.

Engine valve arrangement	GL6000, GL7000		GL9000, GL11000	
	IN.	EX.	IN.	EX.
Adjustable cylinder location of piston				
No.1	☆	☆	☆	☆
No.2	★	☆	★	☆
No.3	—	—	☆	★

☆ : When No.1 piston is at the compression top dead center position.
 ★ : When No.1 piston is at the overlap position.

- (1) Timing Window
- (2) 1TC Mark Line
- (3) Valve Clearance

A : Gear Case Side
[a] GL6000, GL7000
[b] GL9000, GL11000

W1032595

(2) Lubricating System

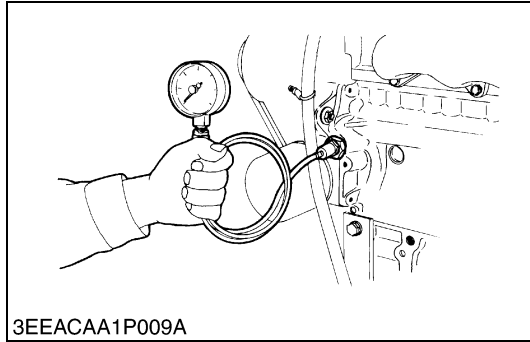

Engine Oil Pressure

1. Remove the engine oil pressure switch, and set an oil pressure tester.
2. Start the engine. After warming up, measure the oil pressure of both idling and rated speeds.
3. If the oil pressure is less than the allowable limit, check the following.
 - Engine oil insufficient
 - Oil pump defective
 - Oil strainer clogged
 - Oil filter cartridge clogged
 - Oil gallery clogged
 - Excessive oil clearance
 - Foreign matter in the relief valve

Engine oil pressure	At idle speed	Factory spec.	More than 49 kPa 0.5 kgf/cm ² 7 psi
	At rated speed	Factory spec.	196 to 441 kPa 2.0 to 4.5 kgf/cm ² 28 to 64 psi
		Allowable limit	147 kPa 1.5 kgf/cm ² 21 psi

(When reassembling)

- After checking the engine oil pressure, tighten the engine oil pressure switch to the specified torque.

Tightening torque	Oil pressure switch	14.7 to 19.6 N·m 1.5 to 2.0 kgf·m 10.8 to 14.5 lbf·ft
-------------------	---------------------	---

W10349520

(3) Cooling System

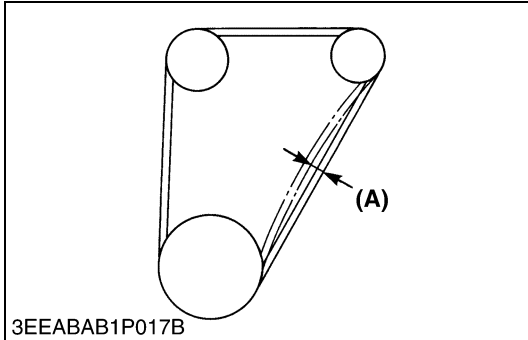

3EEABAB1P017B

Fan Belt Tension

1. Measure the deflection **(A)**, depressing the belt halfway between the fan drive pulley and alternator pulley at specified force 98 N (10 kgf, 22 lbf).
2. If the measurement is not within the factory specifications, adjust the tension adjustment screw.

Deflection (A)	Factory spec.	7.0 to 9.0 mm 0.28 to 0.35 in.
-----------------------	---------------	-----------------------------------

(A) Deflection

W10356670



3EEABAB1P019B

Fan Belt Damage and Wear

1. Check the fan belt for damage.
2. If the fan belt is damaged, replace it.
3. Check if the fan belt is worn and sunk in the pulley groove.
4. If the fan belt is nearly worn out and deeply sunk in the pulley groove, replace it.

(A) Good

(B) Bad

W1016443

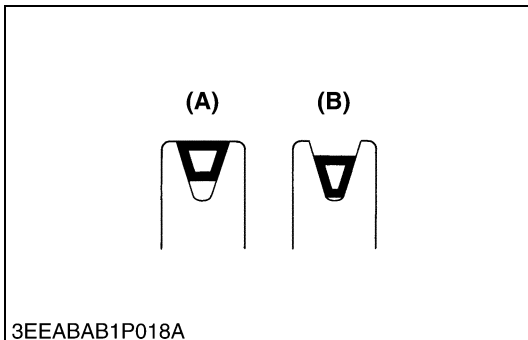

3EEABAB1P018A

Thermostat Valve Opening Temperature

1. Suspend the thermostat in the water by a string with its end inserted between the valve and seat.
2. Heating the water gradually, read the temperature when the valve opens and leaves the string.
3. Continue heating and read the temperature when the valve opens approx. 8 mm (0.315 in.).
4. If the measurement is not within the factory specifications, replace the thermostat.

Thermostat's valve opening temperature	Factory spec.	69.5 to 72.5 °C 157.1 to 162.5 °F
Temperature at which thermostat completely opens	Factory spec.	85 °C 185 °F

W1035849

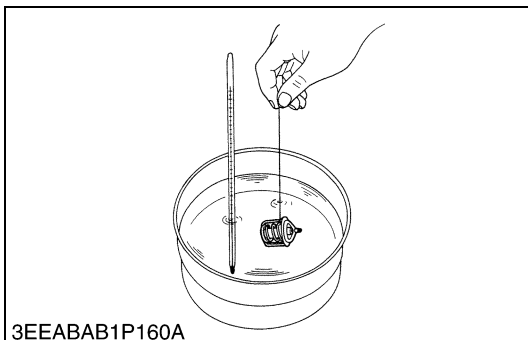

3EEABAB1P160A

CAUTION

- When removing the radiator cap, wait at least ten minutes after the engine has stopped and cooled down. Otherwise, hot water may gush out, scalding nearby people.

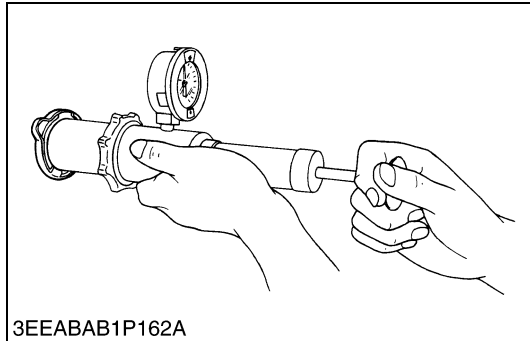

Radiator Cap Air Leakage

- Set a radiator tester and adaptor (BANZAI Code No.: RCT-2A-30S) on the radiator cap.
- Apply the specified pressure (88 kPa, 0.9 kgf/cm², 13 psi), and measure the time for the pressure to fall to 59 kPa (0.6 kgf/cm², 9 psi).
- If the measurement is less than the factory specification, replace the radiator cap.

Pressure falling time	Factory spec.	More than 10 seconds for pressure fall from 88 → 59 kPa 0.9 → 0.6 kgf/cm ² , 13 → 9 psi
-----------------------	---------------	--

W1054156



Radiator Water Leakage

- Pour a specified amount of water into the radiator.
- Set a radiator tester and an adaptor (BANZAI Code No.: RCT-2A-30S) and raise the water pressure to the specified pressure.
- Check the radiator for water leaks.
- For water leak from the pinhole, repair with the radiator cement. When water leak is excessive, replace the radiator.

Radiator water leakage test pressure	Factory spec.	157 kPa 1.6 kgf/cm ² 23 psi
--------------------------------------	---------------	--

W1016903

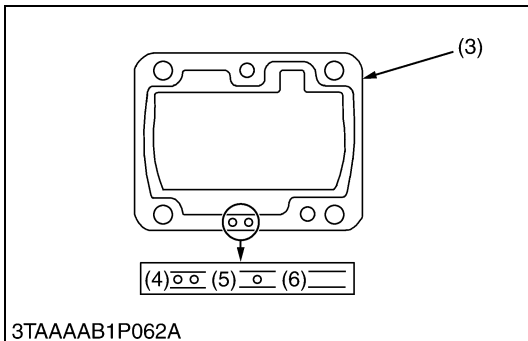
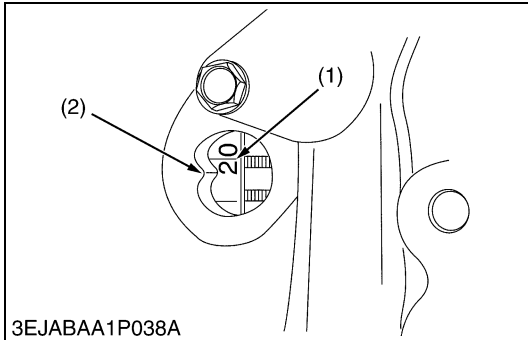
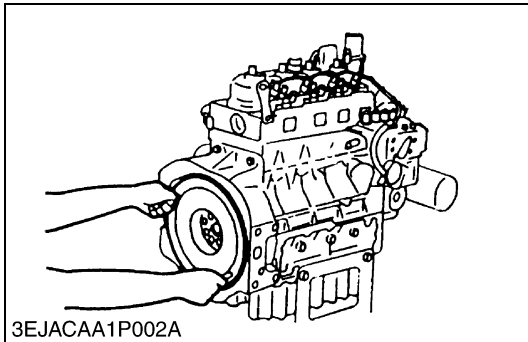
(4) Fuel System**Injection Timing**

1. Remove the injection pipes.
2. Set the speed control lever to the maximum fuel discharge position.
3. Turn the flywheel counterclockwise (facing the flywheel) until fuel flows from the delivery valve holder.
4. Continue to turn the flywheel slowly, and stop it as soon as the fuel level at the tip of the delivery valve holder begins to increase.
5. Check to see if the timing lines (1) on the flywheel is aligned with the alignment mark (2).
6. If the injection timing is out of adjustment, readjust the timing with shims (3).

Injection timing	Factory spec.	0.30 to 0.33 rad (19 to 21 °) before top dead center
------------------	---------------	--

NOTE

- The sealant is applied to both sides of the shim (soft metal gasket shim). The liquid gasket is not required for assembling.
- Shims are available in thickness of 0.20 mm (0.0079 in.), 0.25 mm (0.0098 in.) and 0.30 mm (0.0118 in.). Combine these shims for adjustments.
- Addition or reduction of shim (0.05 mm, 0.0020 in.) delays or advances the injection timing by approx. 0.0087 rad (0.5 °).
- In disassembling and replacing the injection pump, be sure to use the same number of new shims with the same thickness
- Refer to figure below to check the thickness of the shims

(Reference)

- The alignment mark (2) of the injection timing line (1) is not in alignment with the center of the timing window
- The above mark (2) comes aligned with the center of the flywheel housing rib

- | | |
|-----------------------------------|---|
| (1) Timing | (4) Two holes : 0.20 mm (0.0079 in.) |
| (2) Alignment Mark | (5) One hole : 0.25 mm (0.0098 in.) |
| (3) Shim (Soft Metal Gasket Shim) | (6) Without hole : 0.30 mm (0.0118 in.) |

W1018724

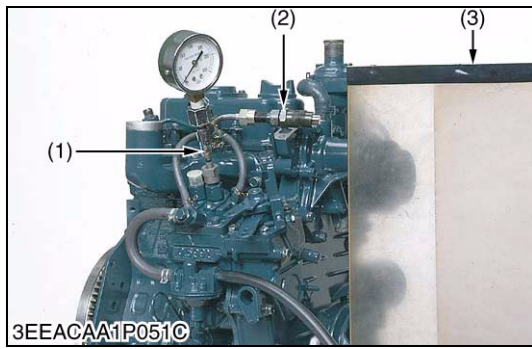

Fuel Tightness of Pump Element

1. Remove the engine stop solenoid.
2. Remove the injection pipes and glow plugs.
3. Install the injection pump pressure tester to the injection pump.
4. Install the injection nozzle (2) jetted with the proper injection pressure to the injection pump pressure tester (1). (Refer to the photo.)
5. Set the speed control lever to the maximum speed position.
6. Run the starter to increase the pressure.
7. If the pressure can not reach the allowable limit, replace the pump with new one or repair with a Kubota-authorized pump service shop.

Fuel tightness of pump element	Allowable limit	13.7 MPa 140 kgf/cm ² 1991 psi
--------------------------------	-----------------	---

NOTE

- **Never try to disassemble the injection pump assembly. For repairs, you are strongly requested to contact a Kubota-authorized pump service shop.**

- (1) Injection Pump Pressure Tester (3) Protection Cover for Jetted Fuel
(2) Injection Nozzle

W1017430

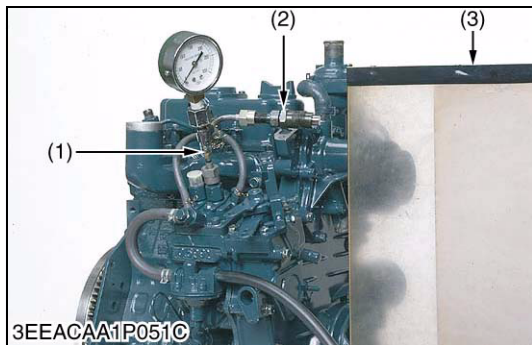

Fuel Tightness of Delivery Valve

1. Remove the engine stop solenoid.
2. Remove the injection pipes and glow plugs.
3. Set a pressure tester to the fuel injection pump.
4. Install the injection nozzle (2) jetted with the proper injection pressure to the injection pump pressure tester (1).
5. Run the starter to increase the pressure.
6. Stop the starter when the fuel jets from the injection nozzle. After that, turn the flywheel by hands and raise the pressure to approx. 13.7 MPa (140 kgf/cm², 1991 psi).
7. Now turn the flywheel back about half a turn (to keep the plunger free). Maintain the flywheel at this position and clock the time taken for the pressure to drop from 13.73 to 12.75 MPa (from 140 to 130 kgf/cm², from 1991 to 1849 psi).
8. Measure the time needed to decrease the pressure from 13.73 to 12.75 MPa (140 to 130 kgf/cm², 1991 to 1849 psi).
9. If the measurement is less than allowable limit, replace the pump with new one or repair with a Kubota-authorized pump service shop.

Fuel tightness of delivery valve	Factory spec.	10 seconds 13.73 → 12.75 MPa 140 → 130 kgf/cm ² 1991 → 1849 psi
	Allowable limit	5 seconds 13.73 → 12.75 MPa 140 → 130 kgf/cm ² 1991 → 1849 psi

NOTE

- **Never try to disassemble the injection pump assembly. For repairs, you are strongly requested to contact a Kubota-authorized pump service shop.**

- (1) Injection Pump Pressure Tester (3) Protection Cover for Jetted Fuel
(2) Injection Nozzle

W1017786

CAUTION

- Check the nozzle injection pressure and condition after you make sure that there is nobody standing in the direction the fume goes.
- If the fume from the nozzle directly contacts the human body, cells may be destroyed and blood poisoning may be caused.

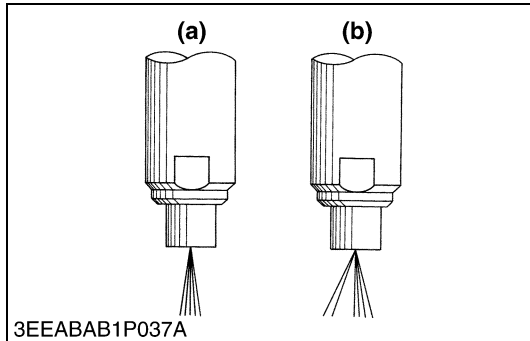

Nozzle Spraying Condition

1. Set the injection nozzle to a nozzle tester, and check the nozzle spraying condition.
2. If the spraying condition is defective, replace the nozzle piece.

(a) Good

(b) Bad

W10181310

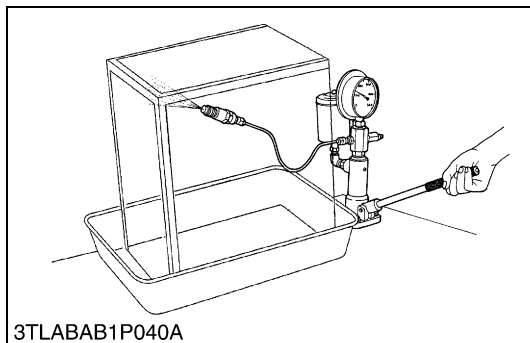

Fuel Injection Pressure

1. Set the injection nozzle to a nozzle tester.
2. Slowly move the tester handle to measure the pressure at which fuel begins jetting out from the nozzle.
3. If the measurement is not within the factory specifications, replace the adjusting washer (1) in the nozzle holder to adjust it.

(Reference)

- Pressure variation with 0.025 mm (0.0010 in.) difference of adjusting washer thickness.
Approx. 235 kPa (2.4 kgf/cm², 34 psi)

Fuel injection pressure	Factory spec.	13.73 to 14.71 MPa 140 to 150 kgf/cm ² 1991 to 2134 psi
-------------------------	---------------	--

(1) Adjusting Washer

W10182100

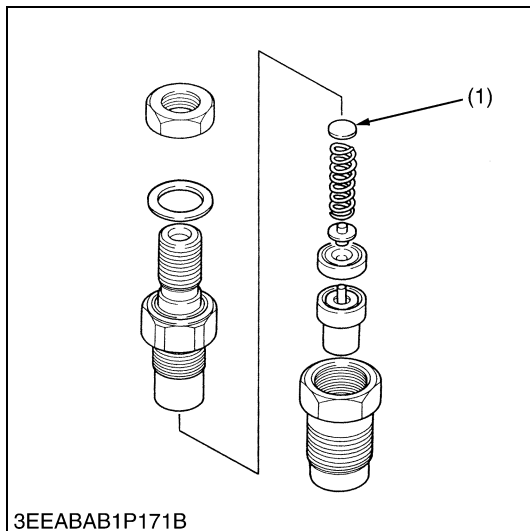

Nozzle Valve Seat Tightness

1. Set the injection nozzle to a nozzle tester.
2. Raise the fuel pressure, and keep at 12.75 MPa (130 kgf/cm², 1849 psi) for 10 seconds.
3. If any fuel leak is found, replace the nozzle piece.

Valve seat tightness	Factory spec.	No fuel leak at 12.75 MPa 130 kgf/cm ² 1849 psi
----------------------	---------------	---

W10183690

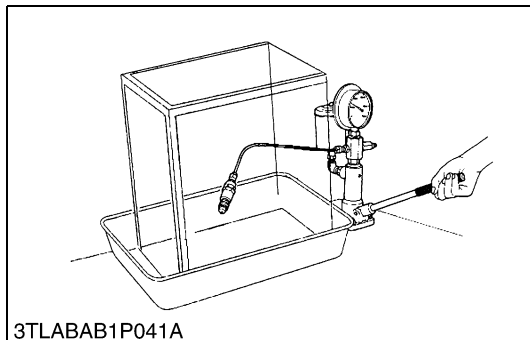

(5) Electrical System



CAUTION

- To avoid accidental short circuit, be sure to attach the positive cable to the positive terminal before the negative cable is attached to the negative terminal.
- Never remove the battery cap while the engine is running.
- Keep electrolyte away from eyes, hands and clothes. If you are splattered with it, wash it away completely with water immediately.
- Keep open sparks and flames away from the battery at all times. Hydrogen gas mixed with oxygen becomes very explosive.

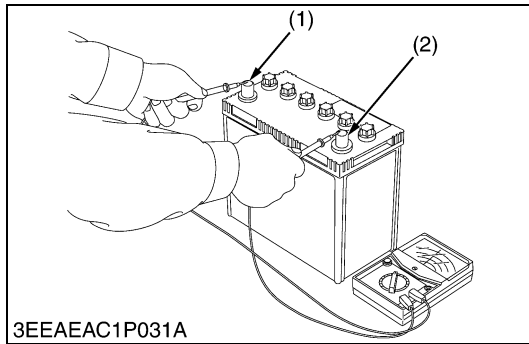

Battery Voltage

1. Stop the engine.
2. Measure the voltage with a circuit tester between the battery terminals.
3. If the battery voltage is less than the factory specification, check the battery specific gravity and recharge the battery.

Battery voltage	Factory spec.	More than 12 V
-----------------	---------------	----------------

(1) Positive Terminal

(2) Negative Terminal

W10125620

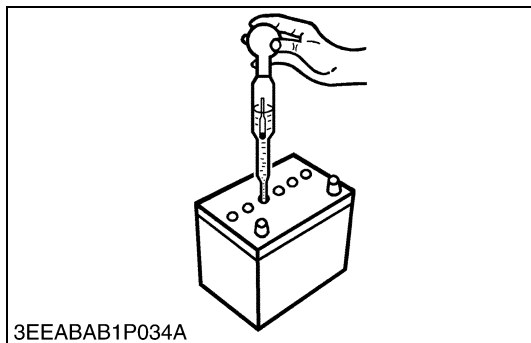

3EEABAB1P034A

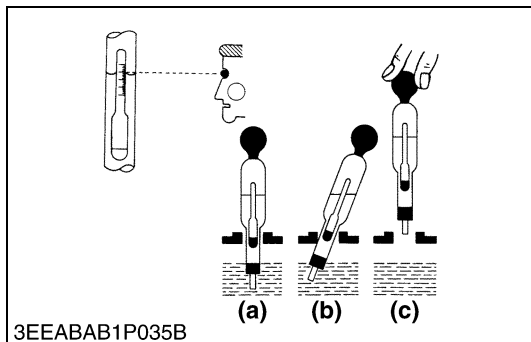

3EEABAB1P035B

Battery Specific Gravity

1. Check the specific gravity of the electrolyte in each cell with a hydrometer.
2. When the electrolyte temperature differs from that at which the hydrometer was calibrated, correct the specific gravity reading following the formula mentioned in **(Reference)**.
3. If the specific gravity is less than 1.215 (after it is corrected for temperature), charge or replace the battery.
4. If the specific gravity differs between any two cells by more than 0.05, replace the battery.

NOTE

- **HOLD the hydrometer tube vertical without removing it from the electrolyte.**
- **Do not suck too much electrolyte into the tube.**
- **Allow the float to move freely and hold the hydrometer at eye level.**
- **The hydrometer reading must be taken at the highest electrolyte level.**

(Reference)

- Specific gravity slightly varies with temperature. To be exact, the specific gravity decreases by 0.0007 with an increase of 1 °C (0.0004 with an increase of 1 °F) in temperature, and increases by 0.0007 with a decreases of 1 °C (0.0004 with a decrease of 1 °F).

Therefore, using 20 °C (68 °F) as a reference, the specific gravity reading must be corrected by the following formula :

- Specific gravity at 20 °C = Measured value + 0.0007 × (electrolyte temperature : 20 °C)
- Specific gravity at 68 °F = Measured value + 0.0004 × (electrolyte temperature : 68 °F)

Specific Gravity	State of Charge
1.260 Sp. Gr.	100 % Charged
1.230 Sp. Gr.	75 % Charged
1.200 Sp. Gr.	50 % Charged
1.170 Sp. Gr.	25 % Charged
1.140 Sp. Gr.	Very Little Useful Capacity
1.110 Sp. Gr.	Discharged

At an electrolyte temperature of 20 °C (68 °F)

(a) Good

(b) Bad

(c) Bad

W1019017

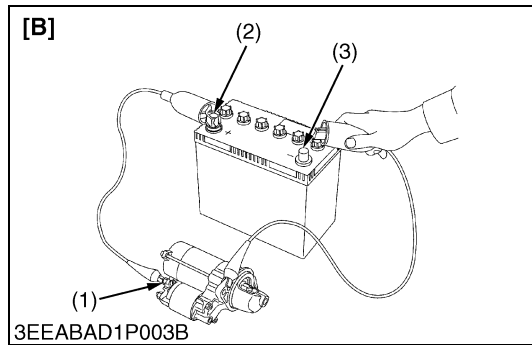
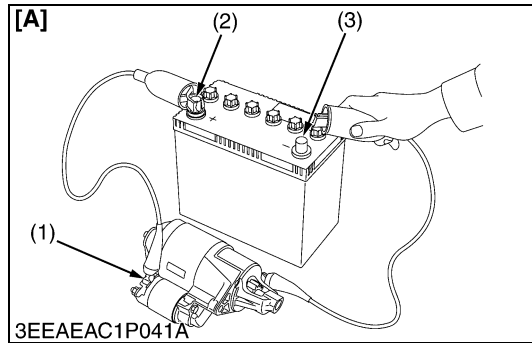
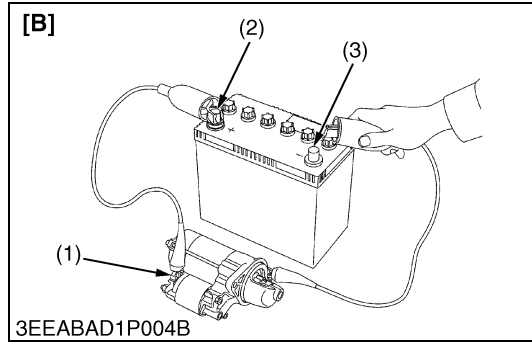
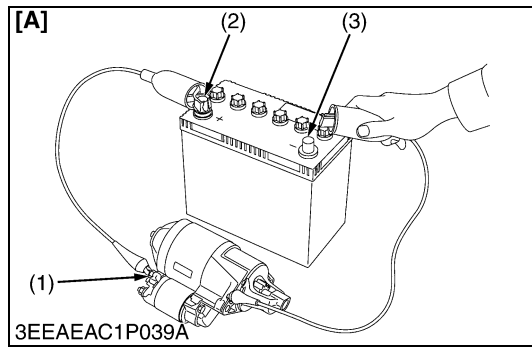

Motor Test

⚠ CAUTION

- **Secure the starter to prevent it from jumping up and down while testing the motor.**
1. Disconnect the battery negative cable from the battery.
 2. Disconnect the battery positive cable from the battery.
 3. Disconnect the leads from the starter **B** terminal.
 4. Remove the starter from the engine.
 5. Connect a jumper lead from the starter **C** terminal (1) to the battery positive terminal (2).
 6. Connect a jumper lead momentarily between the starter's body and the battery negative terminal (3).
 7. If the motor does not run, starter is failure. Repair or replace the starter.

■ NOTE

- **B terminal** : It is the terminal which connects the cable from the battery to the starter.
- **C terminal** : It is the terminal which connects the cable from the motor to the magnet switch.

- | | |
|-----------------------|-----------------------------------|
| (1) C Terminal | [A] Electromagnetic Drive Type |
| (2) Positive Terminal | [B] Planetary Gear Reduction Type |
| (3) Negative Terminal | |

W1019297

Magnetic Switch Test

1. Disconnect the battery negative cable from the battery.
2. Disconnect the battery positive cable from the battery.
3. Disconnect the leads from the starter **B** terminal.
4. Remove the starter from the engine.
5. Connect a jumper lead from the starter **S** terminal (1) to the battery positive terminal (2).
6. Connect a jumper lead momentarily between the starter's body and the battery negative terminal (3).
7. If the pinion gear does not pop out, the magnetic switch is failure. Repair or replace the starter.

■ NOTE

- **B terminal** : It is the terminal which connects the cable from the battery to the starter.
- **S terminal** : It is the terminal which connects the cable from the starter switch to the magnet switch.

- | | |
|-----------------------|-----------------------------------|
| (1) S Terminal | [A] Electromagnetic Drive Type |
| (2) Positive Terminal | [B] Planetary Gear Reduction Type |
| (3) Negative Terminal | |

W1019298

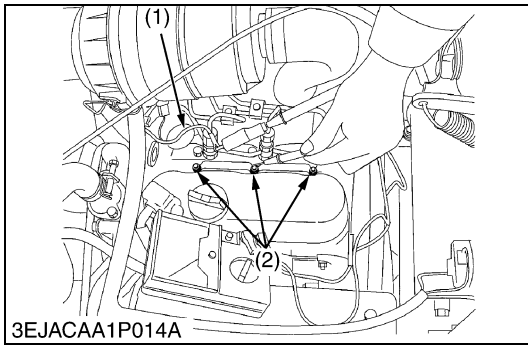

Lead Terminal Voltage

1. Disconnect the wiring lead (1) from the glow plug (2) after turning the main switch off.
2. Turn the main switch key to the "GL" position, and measure the voltage between the lead terminal and the engine body.
3. Turn the main key switch to the "ST" position, and measure the voltage with a voltmeter between the lead terminal and the engine body.
4. If the voltage at either position differs from the battery voltage, the wiring harness or main switch is faulty.

Voltage (Lead terminal - engine body)	Main switch key at "GL"	Approx. battery voltage
	Main switch key at "ST"	Approx. battery voltage

(1) Wiring Lead (Positive)

(2) Glow Plug

W1019299

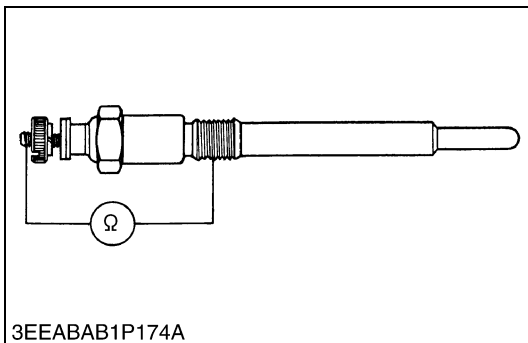

Glow Plug Continuity

1. Disconnect the lead from the glow plugs.
2. Measure the resistance with an ohmmeter between the glow plug terminal and the engine body.
3. If 0 ohm is indicated, the screw at the tip of the glow plug and the housing are short-circuited.
4. If the factory specification is not indicated, the glow plug is faulty.

Glow plug resistance	Factory spec.	Approx. 0.9 Ω
----------------------	---------------	----------------------

W1010726

[2] PREPARATION

(1) Separating Engine



Draining Coolant

⚠ CAUTION

- Do not remove the radiator cap while operating or immediately after stopping. Otherwise, hot water will spout out from the radiator. Wait for more than 10 minutes to cool the radiator, before opening the cap.

1. Place a vessel underneath the water drain plug (1).
2. Open the water drain plug (1), and remove the radiator cap to completely drain the coolant.
3. After all coolant is drained, close the water drain plug (1). Refer to "4. LUBRICANTS, FUEL AND COOLANT" (G-9).

(1) Water Drain Plug

[A] GL6000, GL7000

[B] GL9000, GL11000

W1023465

Draining Engine Oil

⚠ CAUTION

- Be sure to stop the engine before draining the engine oil.

1. After warming up, stop the engine.
2. Place an oil pan underneath the oil drain plug (1).
3. Open the oil drain plug (1), and remove the oil filler cap to completely drain the engine oil.
4. After all engine oil is drained, close the oil drain plug (1). Refer to "4. LUBRICANTS, FUEL AND COOLANT" (G-9).

(1) Oil Drain Plug

[A] GL6000, GL7000

[B] GL9000, GL11000

W1023464

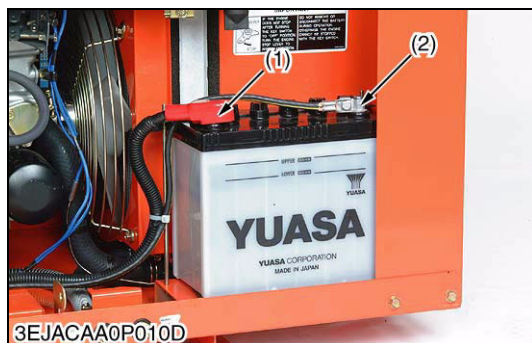

Battery

CAUTION

- Be sure to stop the engine before disconnecting the cables. When removing the battery cables, disconnect the negative cable first. When installing the battery cables, connect the positive cable first.

1. Open the generator door.
2. Disconnect the cable from the battery negative terminal (2).
3. Disconnect the cable from the battery positive terminal (1).

- (1) Positive Terminal (2) Negative Terminal

W1019788

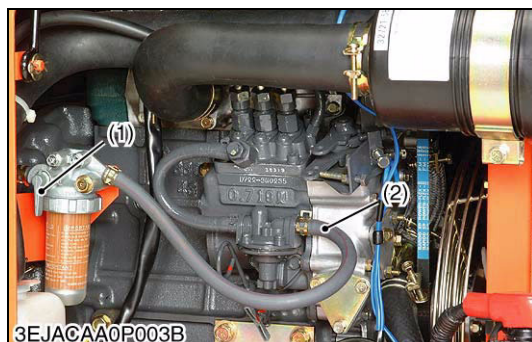

Fuel Hose

CAUTION

- Be sure to stop the engine before removing the fuel hose.

1. Close the fuel valve (1).
2. Remove the fuel hose (2).

- (1) Fuel Valve (2) Fuel Hose

W1045893

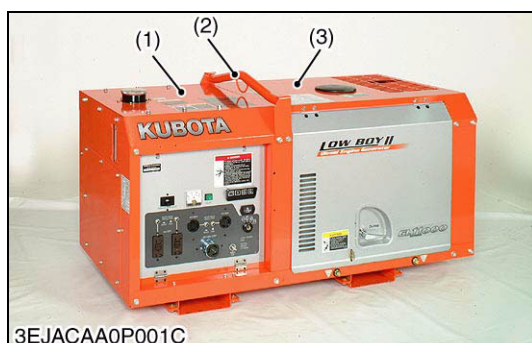

Panel, Cover, Control Panel

1. Close the fuel valve and remove the fuel hose.
2. Remove the hanger (2), the engine roof (3) and the generator roof (1) with fuel tank.
3. Remove the front frame (6) and rear cover (4) and side cover (5).
4. Disconnect the connector between the generator (9) and control panel (10).
5. Disconnect the ground cables (7).
6. Remove the control panel (10) and cooling air port cover (8).

- (1) Generator Roof (6) Front Frame
 (2) Hanger (7) Ground Cables
 (3) Engine Roof (8) Cooling Air Port Cover
 (4) Rear Frame (9) Generator
 (5) Side Cover (10) Control Panel

W1032046

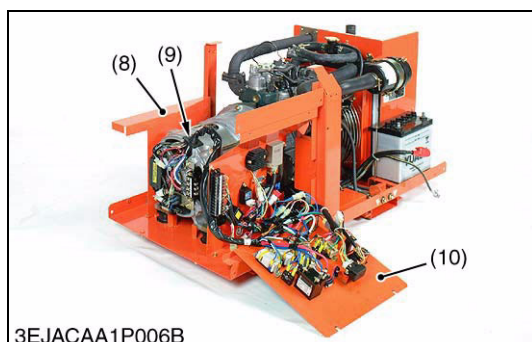
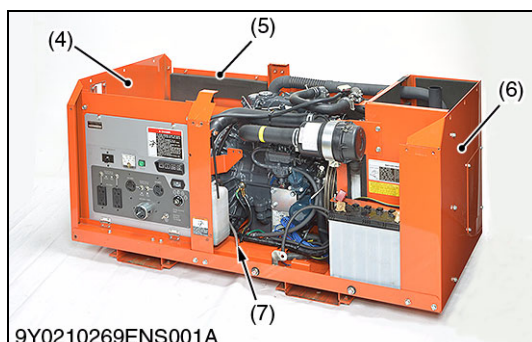

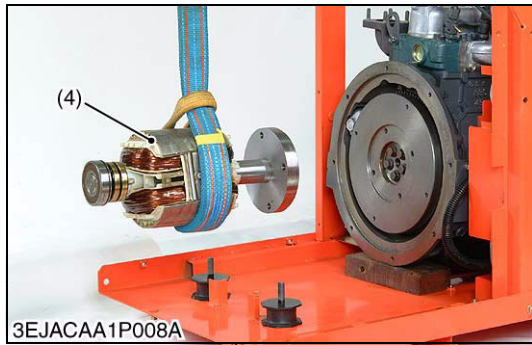
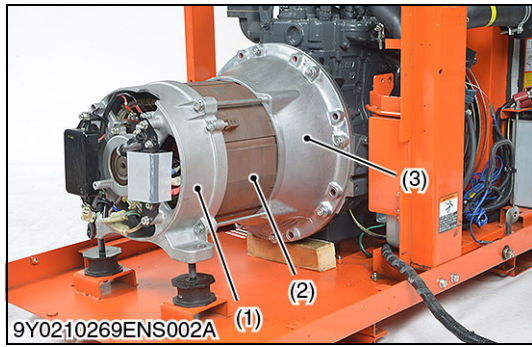

Separating Engine and Generator

1. Disconnect the stator cables.
2. Remove the air cleaner, muffler and radiator hoses.
3. Remove the fan cover.
4. Remove the generator cover and disconnect the wiring harness.
5. Remove the generator mounting nuts.
6. Loosen the engine mounting nuts.
7. Lift up the engine and remove the generator from generator fixed bolt.
8. Remove the rear bracket (1), stator (2), front bracket (3) and rotor (4).

[GL6000, GL7000]

Tightening torque	Generator mounting nut	19.6 to 27.4 N·m 2.0 to 2.8 kgf·m 14.5 to 20.2 lbf·ft
	Stator mounting screw	5.9 to 8.8 N·m 0.6 to 0.9 kgf·m 4.4 to 6.5 lbf·ft
	Rotor assembly mounting screw	34.3 to 44.1 N·m 3.5 to 4.5 kgf·m 25.3 to 32.5 lbf·ft
	PTO shaft	48.1 to 55.9 N·m 4.9 to 5.7 kgf·m 35.5 to 41.2 lbf·ft

[GL9000, GL11000]

Tightening torque	Generator mounting nut	53.9 to 68.6 N·m 5.5 to 7.0 kgf·m 39.8 to 50.6 lbf·ft
	Stator mounting screw	18 to 22 N·m 1.9 to 2.2 kgf·m 14 to 16 lbf·ft
	Rotor assembly mounting screw	19.6 to 27.4 N·m 2.0 to 2.8 kgf·m 14.5 to 20.2 lbf·ft
	Cooling fan mounting screw	19.6 to 27.4 N·m 2.0 to 2.8 kgf·m 14.5 to 20.2 lbf·ft

- (1) Rear Bracket
(2) Stator

- (3) Front Bracket
(4) Rotor

W1049824

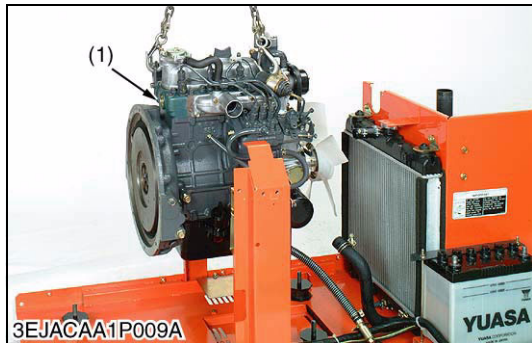

Engine

1. Remove the oil drain hose (2).
2. Remove the engine mounting nuts.
3. Remove the engine (1).

Tightening torque	Engine mounting nut	GL6000 GL7000	19.6 to 27.4 N·m 2.0 to 2.8 kgf·m 14.5 to 20.2 lbf·ft
		GL9000 GL11000	53.9 to 68.6 N·m 5.5 to 7.0 kgf·m 39.8 to 50.6 lbf·ft

- (1) Engine

- (2) Oil Drain Hose

W1035405

[3] DISASSEMBLING AND ASSEMBLING

(1) Cylinder Head and Valves

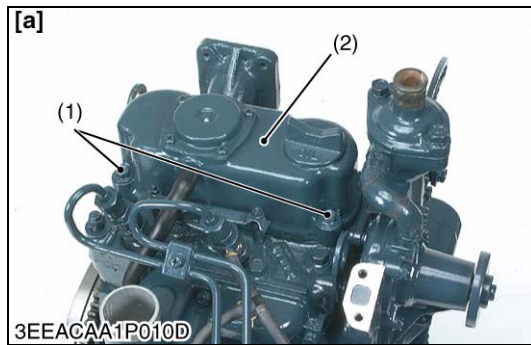

Cylinder Head Cover

1. Remove the cylinder head cover screws (1).
2. Remove the cylinder head cover (2).

(When reassembling)

- Check to see if the cylinder head cover gasket is not defective.

Tightening torque	Cylinder head cover screw	6.86 to 11.3 N·m 0.7 to 1.15 kgf·m 5.1 to 8.3 lbf·ft
-------------------	---------------------------	--

- (1) Cylinder Head Cover Screws
(2) Cylinder Head Cover

[a] GL6000, GL7000
[b] GL9000, GL11000

W1028468

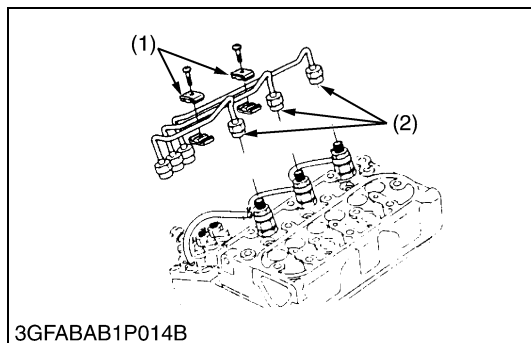
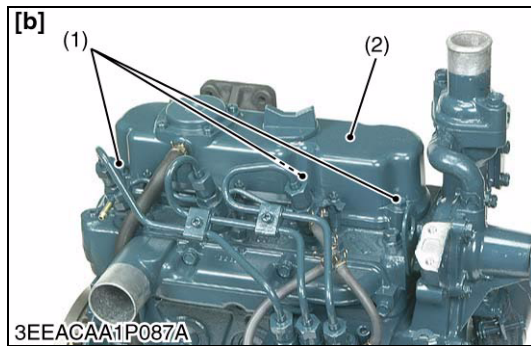

Injection Pipes

1. Loosen the screws to the pipe clamp (1).
2. Remove the injection pipes (2).

(When reassembling)

- Sent compressed air into the pipes to blow out dust. Then, reassemble the pipes in the reverse order.

Tightening torque	Injection pipe retaining nut	24.5 to 34.3 N·m 2.5 to 3.5 kgf·m 18.1 to 25.3 lbf·ft
-------------------	------------------------------	---

- (1) Pipe Clamp

(2) Injection Pipe

W1028640

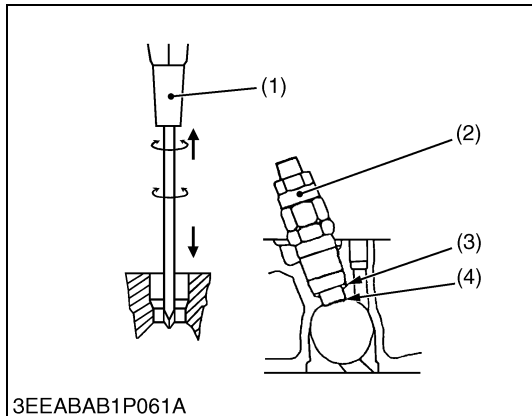
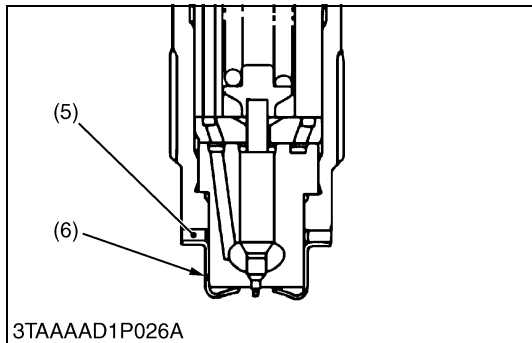
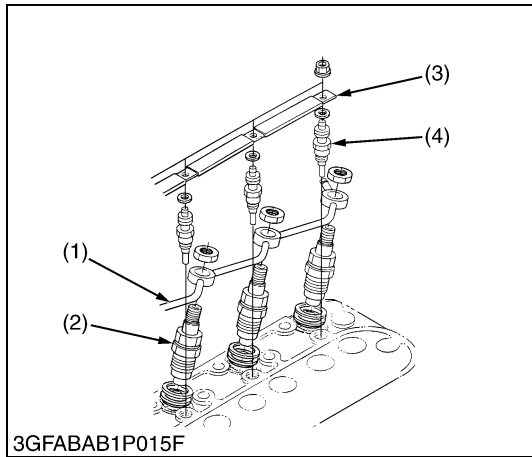

Nozzle Holder Assembly and Glow Plug

1. Remove the overflow pipe (1).
2. Remove the nozzle holder assemblies (2).
3. Remove the copper gasket (5) and heat seal (6).
4. Remove the lead (3) from the glow plugs (4).
5. Remove the glow plugs (4).

(When reassembling)

- Replace the copper gasket and heat seal with new one.

Tightening torque	Overflow pipe retaining nut	19.6 to 24.5 N·m 2.0 to 2.5 kgf·m 14.5 to 18.1 lbf·ft
	Nozzle holder assembly	49.0 to 68.6 N·m 5.0 to 7.0 kgf·m 36.2 to 50.6 lbf·ft
	Glow plug	7.8 to 14.7 N·m 0.8 to 1.5 kgf·m 5.8 to 10.8 lbf·ft

- | | |
|----------------------------|-------------------|
| (1) Overflow Pipe | (4) Glow Plug |
| (2) Nozzle Holder Assembly | (5) Copper Gasket |
| (3) Lead | (6) Heat Seal |

W1024604

Nozzle Heat Seal Removal Procedure

■ IMPORTANT

- Use a plus (phillips head) screw driver (1) that has a diameter which is bigger than the heat seal hole (Approx. 6 mm (1/4 in.)).

1. Drive screw driver (1) lightly into the heat seal hole.
2. Turn screw driver three or four times each way.
3. While turning the screw driver, slowly pull the heat seal (4) out together with the injection nozzle gasket (3).
4. If the heat seal drops, repeat the above procedure.

(When reassembling)

- Heat seal (4) and injection nozzle gasket (3) must be changed when the injection nozzle is removed for cleaning or for service.

- | | |
|-----------------------|-----------------------------|
| (1) Plus Screw Driver | (3) Injection Nozzle Gasket |
| (2) Injection Nozzle | (4) Heat Seal |

W1021255

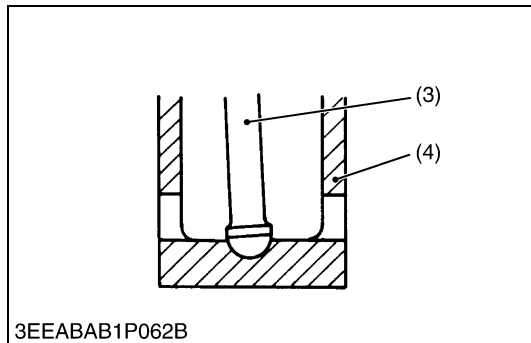
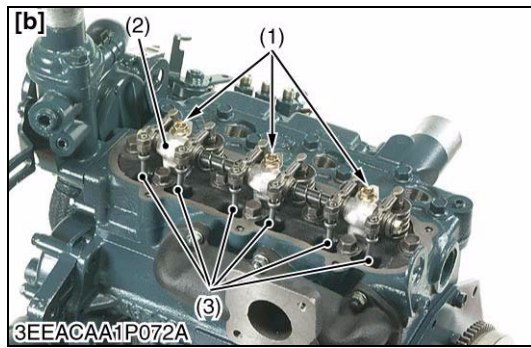
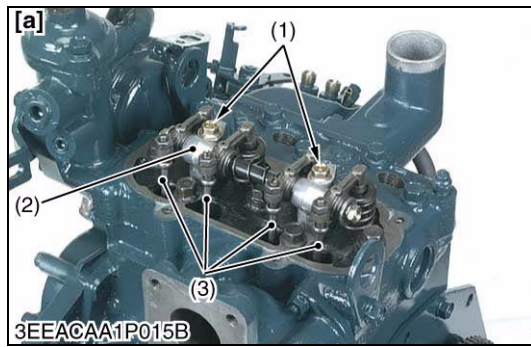

Rocker Arm and Push Rod

1. Remove the rocker arm bracket screws (1).
2. Remove the rocker arm assembly (2).
3. Remove the push rods (3).

(When reassembling)

- When putting the push rods (3) onto the tappets (4), check to see if their ends are properly engaged with the dimples.

■ IMPORTANT

- **After installing the rocker arm, be sure to adjust the valve clearance.**

Tightening torque	Rocker arm bracket screw	9.8 to 11.3 N·m 1.00 to 1.15 kgf·m 7.2 to 8.3 lbf·ft
-------------------	--------------------------	--

- (1) Rocker Arm Bracket Screws [a] GL6000, GL7000
- (2) Rocker Arm Assembly [b] GL9000, GL11000
- (3) Push Rod
- (4) Tappet

W1021437

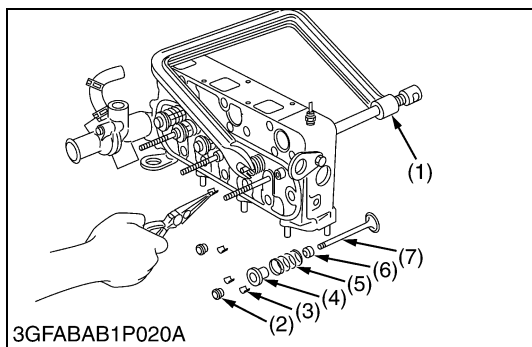
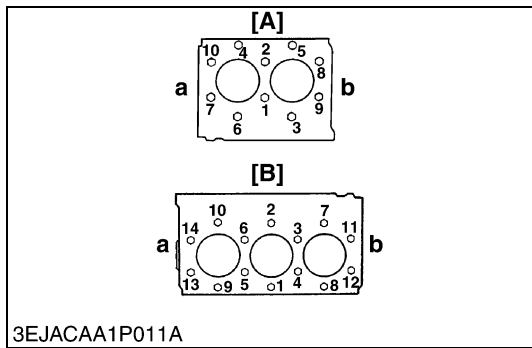
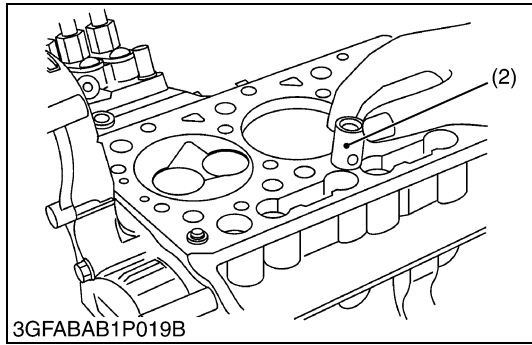
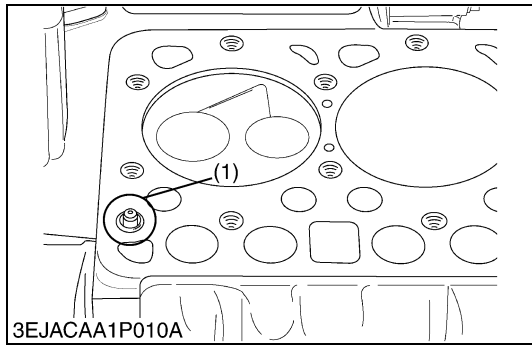

Cylinder Head and Tappet

1. Remove the cylinder head screws in the order of [10] or [14] to [1] and remove the cylinder head.
2. Remove the cylinder head gasket and O-ring (1).
3. Remove the tappets (2) from the crankcase.

(When reassembling)

- Replace the cylinder head gasket with a new one.
- Before installing the tappets (2), apply engine oil thinly around them.
- Install the cylinder head, using care not to damage the O-ring (1).
- Tighten the cylinder head screw gradually screw in the order of [1] to [10] or [14] after applying engine oil.
- Retighten the cylinder head screw after running the engine for 30 minutes.

NOTE

- **Mark the cylinder number to the tappets to prevent interchanging.**
- **When reusing the head bolt, apply engine oil to its thread (when use a new head bolt "rust-preventive oil applied" use it without applying engine oil to it) and seat surface before fitting it. After installing the engine, let it run for 30 minutes, and retighten the head bolt. (Before retightening it loosen it by 0.52 to 0.79 rad (30 to 90 °).)**

Tightening torque	Cylinder head screw	37.3 to 42.2 N·m 3.8 to 4.3 kgf·m 27.5 to 31.1 lbf·ft
-------------------	---------------------	---

- (1) O-ring
- (2) Tappet

- a : Gear Case Side
- b : Flywheel Side
- [A] GL6000, GL7000
- [B] GL9000, GL11000

W1025645

Valves

1. Remove the valve caps (2).
2. Remove the valve spring collet (3), pushing the valve spring retainer (4) by valve spring replacer (1).
3. Remove the valve spring retainer (4), valve spring (5) and valve stem seal (6).
4. Remove the valve (7).

(When reassembling)

- Wash the valve stem seal and valve guide hole, and apply engine oil sufficiently.
- After installing the valve spring collets, lightly tap the stem to assure proper fit with a plastic hammer.

IMPORTANT

- **Do not change the combination of valve and valve guide.**

- (1) Valve Spring Replacer
- (2) Valve Cap
- (3) Valve Spring Collet
- (4) Valve Spring Retainer
- (5) Valve Spring
- (6) Valve Stem Seal
- (7) Valve

W10211070

(2) Timing Gears, Camshaft, Fuel Camshaft and Oil Pan

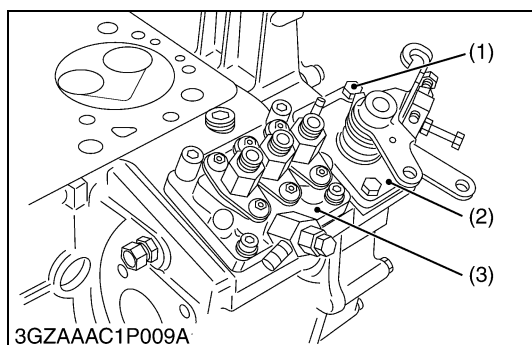

Injection Pump, Fuel Feed Pump and Speed Control Plate

1. Remove the fuel feed pump.
2. Remove the screws and separate the speed control plate (2), taking care not to damage the governor spring (4).
3. Remove the screws and separate the speed control plate (2), taking care not to damage start spring (5).
4. Disconnect the start spring (5) and remove the speed control plate (2).

(When reassembling)

- Hook the governor spring (4) to the lever (6) first and install the speed control plate (2).
- Be sure to place the copper washers underneath two screws (1).
- Position the slot (10) on the fork lever just under the slot (9) on the crankcase.
- Insert the injection pump (3) so that the control rod (8) should be pushed by the high idle spring (7) at its end and the pin (11) on the rod engages with the slot (10) on the fork lever.

NOTE

- **The sealant is applied to both sides of the soft metal gasket shim. The liquid gasket is not required for assembling.**
- **Addition or reduction of shim (0.025 mm, 0.0010 in.) delays or advances the injection timing by approx. 0.0087 rad (0.5 °).**
- **In disassembling and replacing, be sure to use the same number of new gasket shims with the same thickness.**

- | | |
|-------------------------|-----------------------------|
| (1) Screw | (7) High Idle Spring |
| (2) Speed Control Plate | (8) Control Rod |
| (3) Injection Pump | (9) Slot (Crankcase Side) |
| (4) Governor Spring | (10) Slot (Fork Lever Side) |
| (5) Start Spring | (11) Pin |
| (6) Lever | |

W1148604

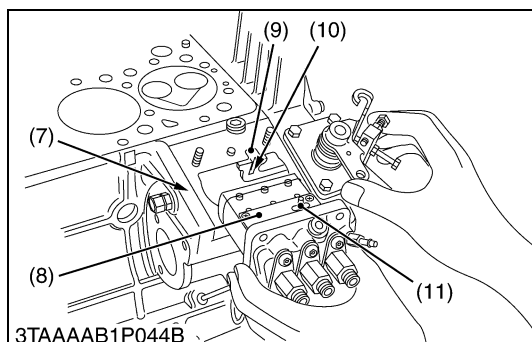
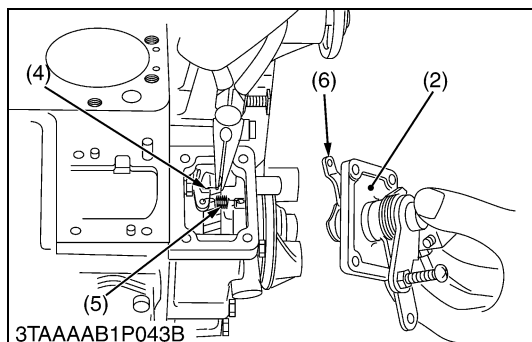

Fan Drive Pulley

1. Set the stopper to the flywheel.
2. Remove the fan drive pulley screw.
3. Draw out the fan drive pulley with a puller.

(When reassembling)

- Install the pulley to the crankshaft, aligning the alignment mark (1) on them.
- Apply engine oil to the fan drive pulley retaining screws. And tighten them.

Tightening torque	Fan drive pulley screw	98.1 to 107.9 N·m 10.0 to 11.0 kgf·m 72.3 to 79.6 lbf·ft
-------------------	------------------------	--

- (1) Alignment Mark

W10181950

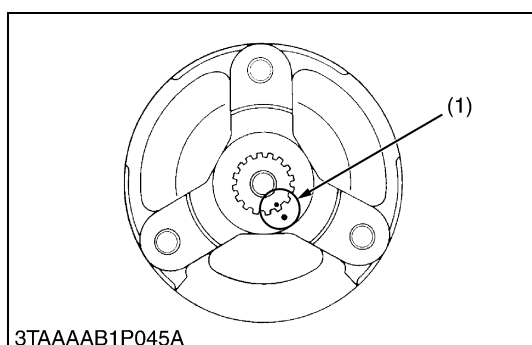

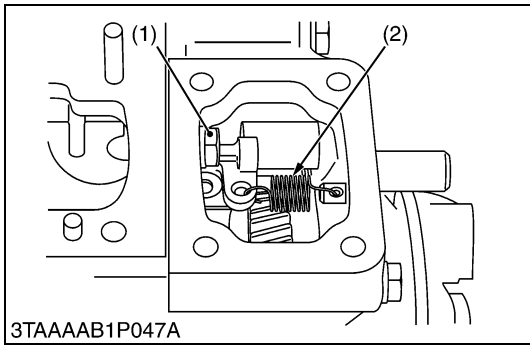

Gear Case

1. Remove the screw (1) of inside the gear case and outside screws (6).
2. Disconnect the start spring (2) in the speed control plate mounting hole.
3. Remove the gear case (3).

(When reassembling)

- Apply a liquid gasket (Three Bond 1215 or equivalent) to both sides of the gear case gasket (4).
- Be sure to set three O-rings (5) inside the gear case.

- | | |
|--------------------|----------------------|
| (1) Screw (Inside) | (4) Gear Case Gasket |
| (2) Start Spring | (5) O-ring |
| (3) Gear Case | (6) Screw |

W1029858

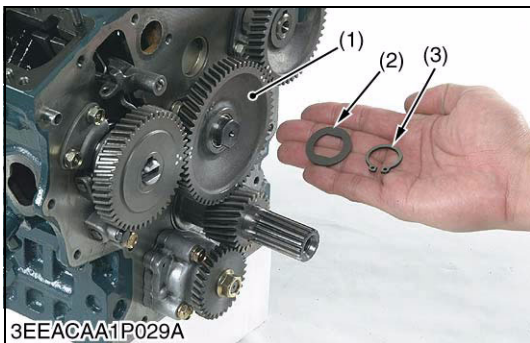
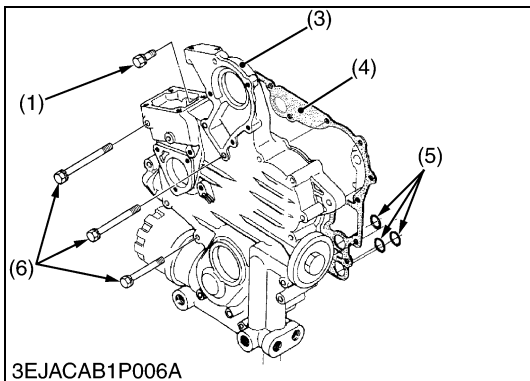

Idle Gear

1. Remove the external snap ring (3), the idle gear collar (2) and the idle gear (1).

(When reassembling)

- Install the idle gear, aligning the alignment mark (4) on the gears referring to the figure.

Tightening torque	Idle gear shaft mounting screw	9.8 to 11.3 N·m 1.00 to 1.15 kgf·m 7.2 to 8.3 lbf·ft
-------------------	--------------------------------	--

- | | |
|----------------------|------------------------|
| (1) Idle Gear | (3) External Snap Ring |
| (2) Idle Gear Collar | (4) Alignment Mark |

W1030437

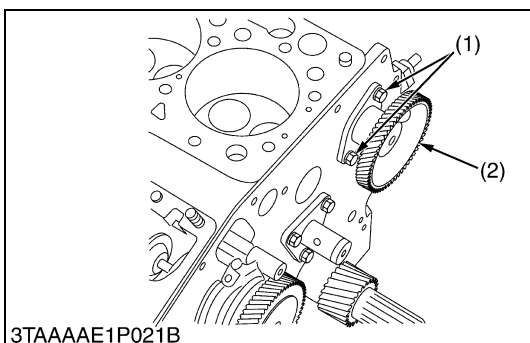
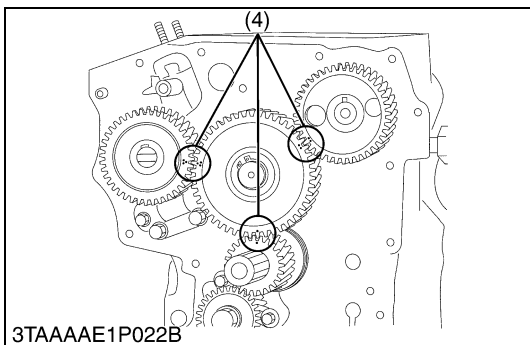

Camshaft

1. Remove the camshaft mounting screws (1) and draw out the camshaft with gear (2) on it.

(When reassembling)

- When install the camshaft, apply engine oil to the camshaft journals.
- Apply engine oil to the camshaft mounting screws. And tighten them.

- | | |
|-----------------------------|-------------------|
| (1) Camshaft Mounting Screw | (2) Camshaft Gear |
|-----------------------------|-------------------|

W1030808

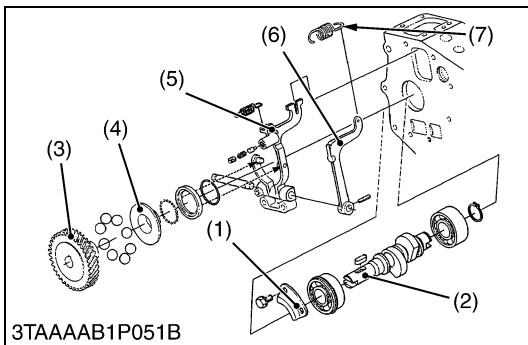

Fuel Camshaft

1. Remove the retaining plate (1).
2. Remove the fork lever holder mounting screws (8), then draw out the injection pump gear (3) and fuel camshaft (2) with the governor fork assembly.

(When reassembling)

- Hook the governor spring (7) to the fork lever 2 (6) before installing the fork lever assembly to the crankcase.

- | | |
|-------------------------|--------------------------------------|
| (1) Retaining Plate | (5) Fork Lever 1 |
| (2) Fuel Camshaft | (6) Fork Lever 2 |
| (3) Injection Pump Gear | (7) Governor Spring |
| (4) Governor Sleeve | (8) Fork Lever Holder Mounting Screw |

W10178820

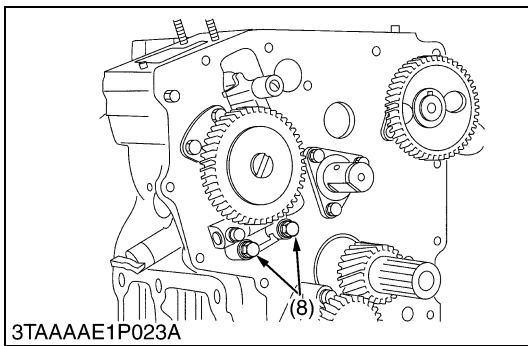

Oil Pump and Crankshaft Gear

1. Remove the oil pump gear (5).
2. Remove the oil pump (6).
3. Remove the collar (4), O-ring (3) and crankshaft oil slinger (2).
4. Remove the crankshaft gear (1) with a puller.

(When reassembling)

- Install the collar (4) after aligning the marks on the gears. (See page the figure at "Idle Gear".)

- | | |
|----------------------------|-----------------------|
| (1) Crankshaft Gear | (4) Crankshaft Collar |
| (2) Crankshaft Oil Slinger | (5) Oil Pump Gear |
| (3) O-ring | (6) Oil Pump |

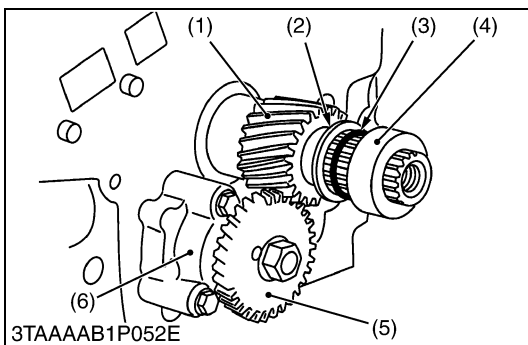

W10180290

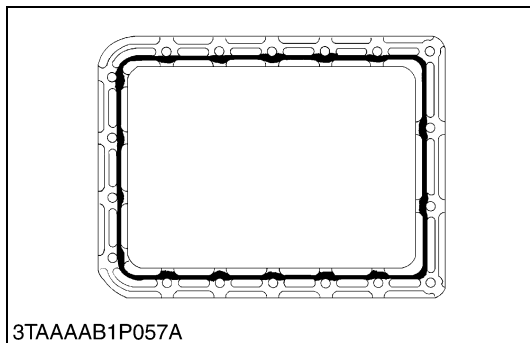
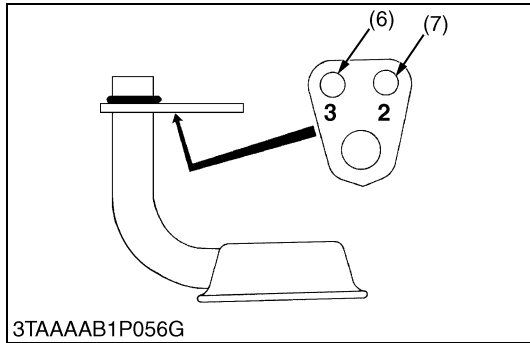
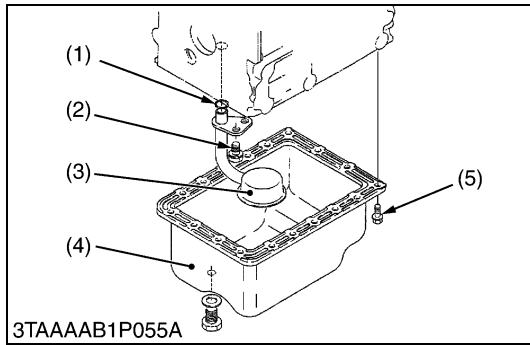

Oil Pan and Oil Strainer

1. Remove the oil pan mounting screws (5).
2. Remove the oil pan (4) by lightly tapping the rim of the pan with a wooden hammer.
3. Remove the oil strainer (3).

(When reassembling)

- After cleaning the oil strainer, check to see that the filter mesh is in clean, and install it.
- Visually check the O-ring (1), apply engine oil, and install it.
- Securely fit the O-ring to the oil strainer.
- To avoid uneven tightening, tighten oil pan mounting screws (5) in diagonal order from the center.

For GL6000, GL7000

- Using the hole (7) numbered "2", install the oil strainer by mounting screw.

For GL9000, GL11000

- Using the hole (6) numbered "3", install the oil strainer by mounting screw.

■ IMPORTANT

- **Scrape off the old adhesive completely. Wipe the sealing surface clean using waste cloth soaked with gasoline. Now apply new adhesive 3 to 5 mm (0.12 to 0.20 in.) thick all over the contact surface. Apply the adhesive also on the center of the flange as well as on the inner wall of each bolt hole.**
 - **Cut the nozzle of the "liquid gasket" (Three Bond 1207D or equivalent) container at its second notch. Apply "liquid gasket" about 5 mm (0.20 in.) thick.**
- Within 20 minutes after the application of fluid sealant, reassemble the components. Wait then for about 30 minutes, and pour oil in the crankcase.**

- | | |
|------------------|--------------------------------|
| (1) O-ring | (5) Oil Pan Mounting Screw |
| (2) Screw | (6) Hole (for GL6000, GL7000) |
| (3) Oil Strainer | (7) Hole (for GL9000, GL11000) |
| (4) Oil Pan | |

W10236610

(3) Piston and Connecting Rod

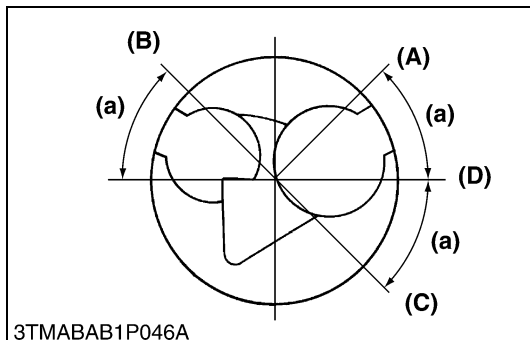
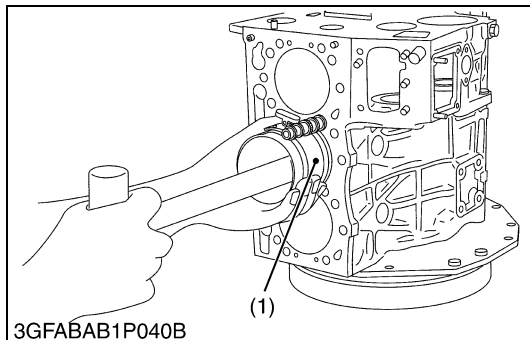
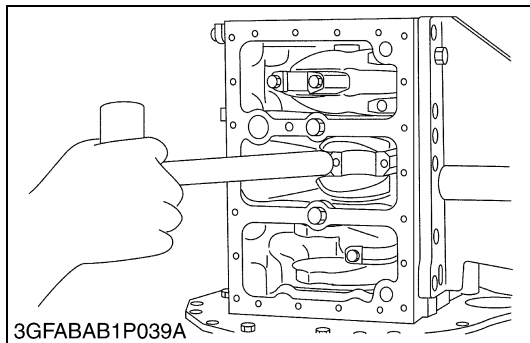
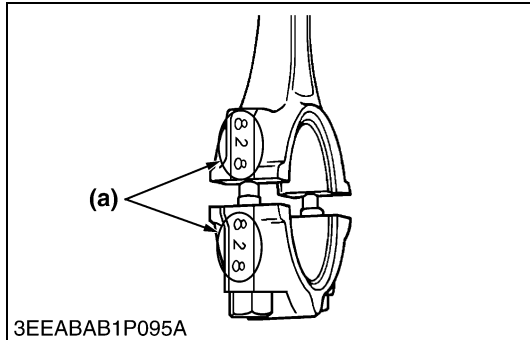
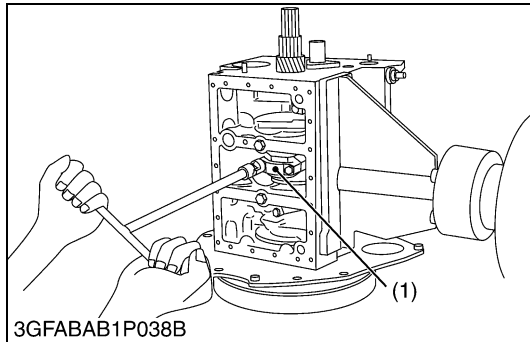

Connecting Rod

1. Remove the connecting rod caps (1).

(When reassembling)

- Align the marks (a) with each other. (Face the marks toward the injection pump.)
- Apply engine oil to the connecting rod screws and lightly screw it in by hand, then tighten it to the specified torque.

If the connecting rod screw won't be screwed in smoothly, clean the threads.

If the connecting rod screw is still hard to screw in, replace it.

Tightening torque	Connecting rod screw	26.5 to 30.4 N·m 2.7 to 3.1 kgf·m 19.5 to 22.4 lbf·ft
-------------------	----------------------	---

(1) Connecting Rod Cap

(a) Mark

W10275480

Pistons

1. Turn the flywheel and bring the piston to top dead center.
2. Draw out the piston upward by lightly tapping it from the bottom of the crankcase with the grip of a hammer.
3. Draw out the other piston in the same method as above.

(When reassembling)

- Before inserting the piston into the cylinder, apply enough engine oil to the piston.
- When inserting the piston into the cylinder, face the mark on the connecting rod to the injection pump.

■ IMPORTANT

- **Do not change the combination of cylinder and piston. Make sure of the position of each piston by marking. For example, mark "1" on the No.1 piston.**
- **Place the piston rings with their gaps at 0.79 rad (45°) from the piston pin's direction at shown in the figure.**
- **Carefully insert the pistons using a piston ring compressor (1).**

(1) Piston Ring Compressor

(A) Top Ring Gap
(B) Second Ring Gap
(C) Oil Ring Gap
(D) Piston Pin Hole
(a) 0.785 rad (45°)

W10277450

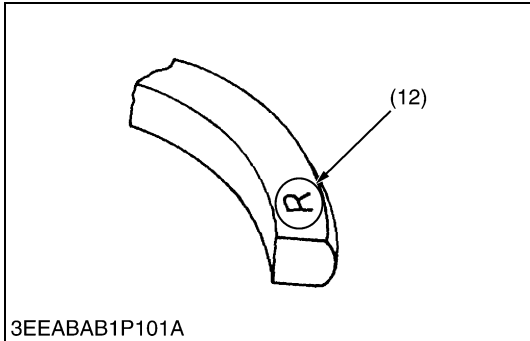
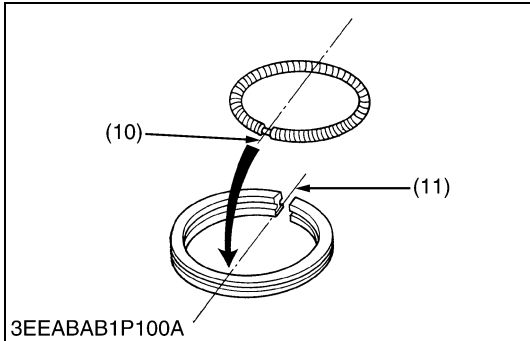
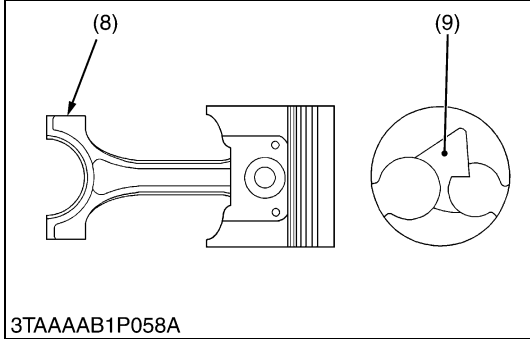
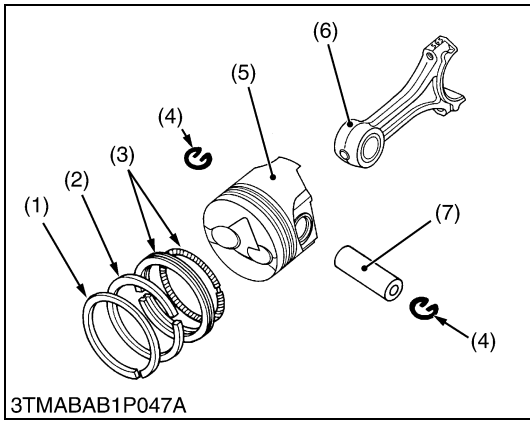

Piston Ring and Connecting Rod

1. Remove the piston rings using a piston ring tool.
2. Remove the piston pin (7), and separate the connecting rod (6) from the piston (5).

(When reassembling)

- When installing the ring, assemble the rings so that the manufacturer's mark (12) near the gap faces the top of the piston.
- When installing the oil ring onto the piston, place the expander joint (10) on the opposite side of the oil ring gap (11).
- Apply engine oil to the piston pin.
- When installing the connecting rod to the piston, immerse the piston in 80 °C (176 °F) oil for 10 to 15 minutes and insert the piston pin to the piston.
- When installing the connecting rod to the piston, align the mark (8) on the connecting rod to the fan-shaped concave (9).

■ IMPORTANT

- **Mark the same number on the connecting rod and the piston so as not to change the combination.**

- | | |
|--------------------------|--------------------------|
| (1) Top Ring | (7) Piston Pin |
| (2) Second Ring | (8) Mark |
| (3) Oil Ring | (9) Fan-Shaped Concave |
| (4) Piston Pin Snap Ring | (10) Expander Joint |
| (5) Piston | (11) Oil Ring Gap |
| (6) Connecting Rod | (12) Manufacturer's Mark |

W10281670

(4) Crankshaft

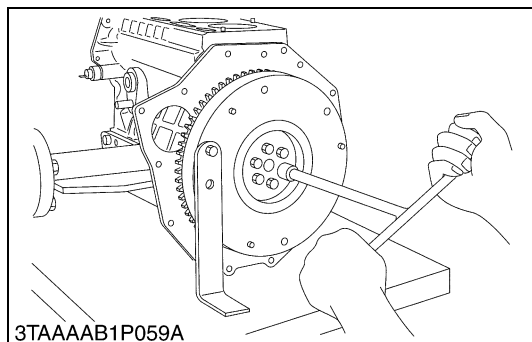

Flywheel

1. Fit the stopper to the flywheel.
2. At first, remove two pieces of the flywheel screws.
3. Insert two pieces of the flywheel guide screws in the holes.
4. Remove all flywheel screws.
5. Remove the flywheel slowly along the flywheel guide screws.

(When reassembling)

- Insert two pieces of the flywheel guide screws.
- Fit the flywheel giving care to the position.
- Apply engine oil to the threads and the undercut surface of the flywheel bolt and fit the bolt.

Tightening torque	Flywheel screw	53.9 to 58.8 N·m 5.5 to 6.0 kgf·m 39.8 to 43.4 lbf·ft
-------------------	----------------	---

W1030810

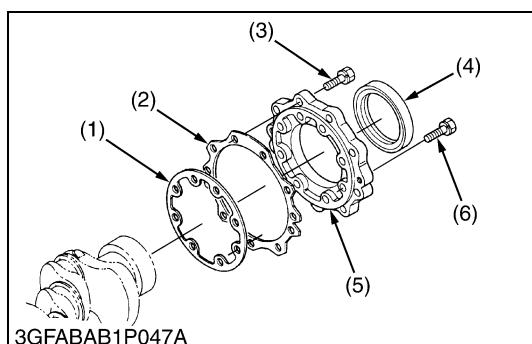

Bearing Case Cover

1. Remove the bearing case cover mounting screws (3), (6). First, remove inside screws (6) and then outside screws (3).
2. Remove the bearing case cover (5).

■ IMPORTANT

- **The length of inside screws and outside screws are different. Do not take a mistake using inside screws and outside screws.**

(When reassembling)

- Fit the bearing case gasket (1) and the bearing case cover gasket (2) with correct directions.
- Install the bearing case cover to position the casting mark "UP" on it upward.
- Apply engine oil to the oil seal lip and take care that it is not rolled when installing.
- Tighten the bearing case cover mounting screws with even force on the diagonal line.

Tightening torque	Bearing case cover mounting screw	9.8 to 11.3 N·m 1.00 to 1.15 kgf·m 7.2 to 8.3 lbf·ft
-------------------	-----------------------------------	--

- (1) Bearing Case Gasket (5) Bearing Case Cover
 (2) Bearing Case Cover Gasket (6) Bearing Case Cover Mounting Screw
 (3) Bearing Case Cover Mounting Screw (Inside M6 x 20)
 (Outside M6 x 22)

(4) Oil Seal (a) **Upside**

W1031168

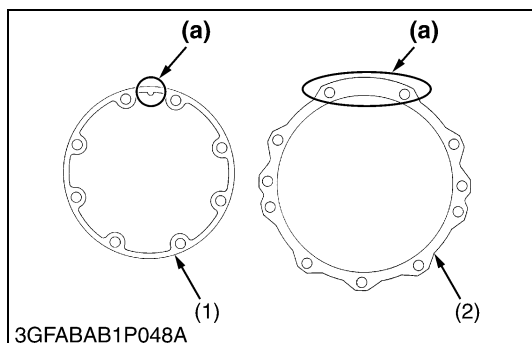

Crankshaft Assembly

1. Remove the main bearing case screw 2 (1).
2. Pull out the crankshaft assembly.

(When reassembling)

- Clean the oil passage of the crankshaft with compressed air.
- Apply oil to the main bearing case screw 2 (1).
- Install the crankshaft assembly, aligning the screw hole of main bearing case with the screw hole of crankcase.

Tightening torque	Main bearing case screw 2	26.5 to 30.4 N·m 2.7 to 3.1 kgf·m 19.5 to 22.4 lbf·ft
-------------------	---------------------------	---

(1) Main Bearing Case Screw 2

W1031360

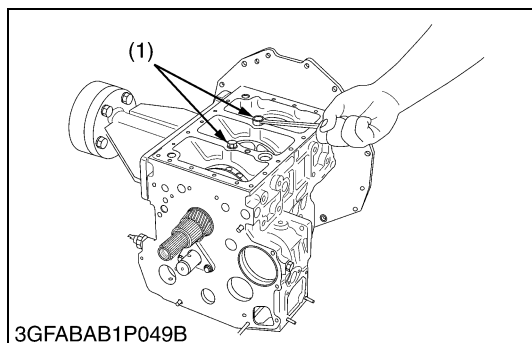

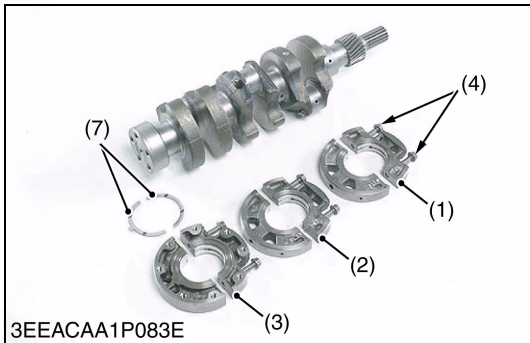
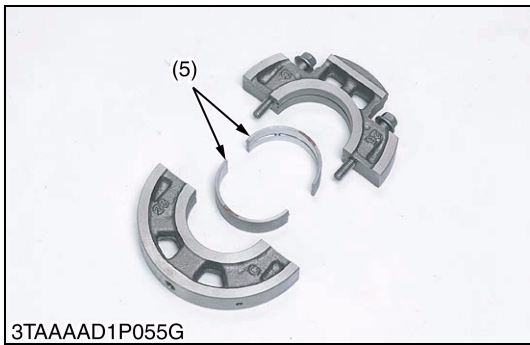
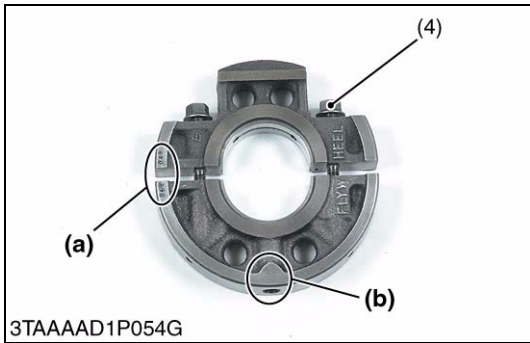
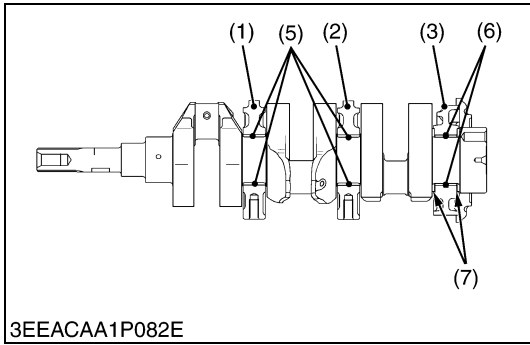
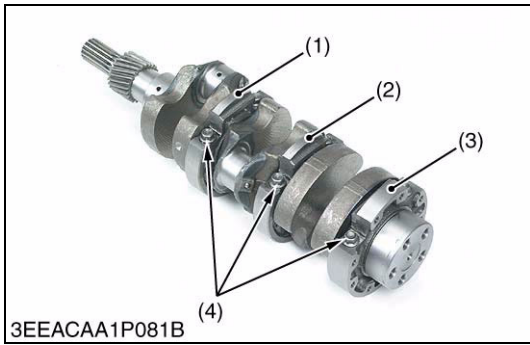

Main Bearing Case Assembly

1. Remove the two main bearing case screws 1 (4), and remove the main bearing case assembly 1 (1) being careful with crankshaft bearings 3 (5).
2. Remove the main bearing case assembly 2 (2) and the main bearing case assembly (3) as above. Keep in mind, however, that the thrust bearing (7) is installed in the main bearing case assembly (3).

(When reassembling)

- Clean the oil passage in the main bearing cases.
- Apply clean engine oil on bearings.
- Install the main bearing case assemblies in original positions. Since diameters of main bearing cases vary, install them in order to marking **(b)** (1 for GL6000, GL7000 and 1, 2 for GL9000, 11000) from the gear case side. (Refer to the figure.)
- Match the alignment number **(a)** on all main bearing case assembly 1.
- Do the same for the main bearing case assembly 2 (2) and the main bearing case assembly (3) too.
- When installing the main bearing case 1 and 2, face the mark "FLYWHEEL" to the flywheel.
- Install the thrust bearing (7) with its oil groove facing outward.
- Make sure that the main bearing case moves smoothly after tightening the main bearing case screw 1 to the specified torque.

Tightening torque	Main bearing case screw 1	12.7 to 15.7 N·m 1.3 to 1.6 kgf·m 9.4 to 11.6 lbf·ft
-------------------	---------------------------	--

- (1) Main Bearing Case Assembly 1
 - (2) Main Bearing Case Assembly 2
 - (3) Main Bearing Case Assembly
 - (4) Main Bearing Case Screw 1
 - (5) Crankshaft Bearing 3
 - (6) Crankshaft Bearing 2
 - (7) Thrust Bearing
- (a) Alignment Number**
 - (b) Marking (1 or 2)**

W1034602

(5) Water Pump

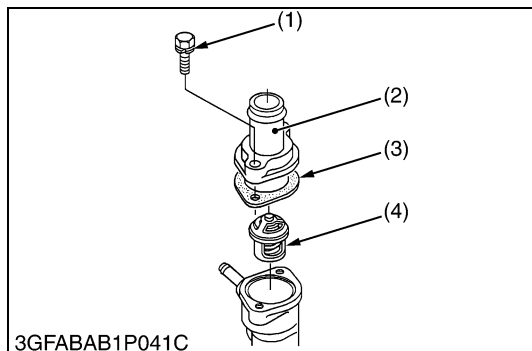

Thermostat Assembly

1. Remove the thermostat cover mounting screws (1), and remove the thermostat cover (2).
2. Remove the thermostat assembly (4).

(When reassembling)

- Apply a liquid gasket (Three Bond 1215 or equivalent) to both side of the gasket (3).

- (1) Thermostat Cover Mounting Screw (3) Thermostat Cover Gasket
 (2) Thermostat Cover (4) Thermostat Assembly

W10393690

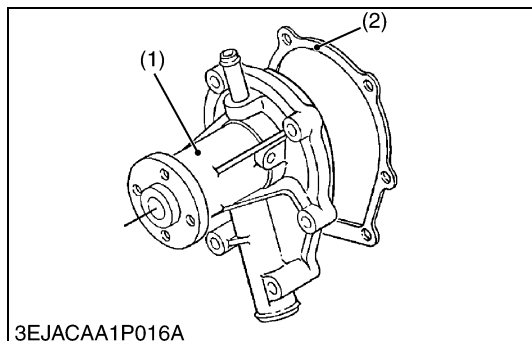

Water Pump Assembly

1. Loosen the tension adjustment screw, and remove the fan belt.
2. Remove the fan and fan pulley.
3. Remove the water pump assembly (1) from the gear case cover.
4. Remove the water pump flange.

(When reassembling)

- Apply a liquid gasket (Three Bond 1215 or equivalent) to the both sides of gasket (2).

- (1) Water Pump Assembly (2) Water Pump Gasket

W10395040

(6) Injection Nozzle

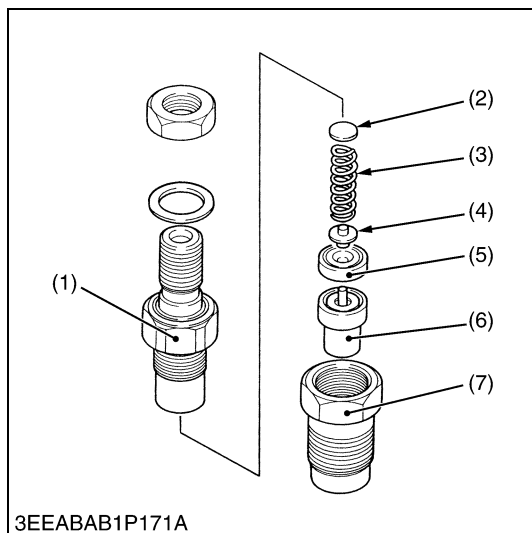

Nozzle Holder

1. Secure the nozzle retaining nut (7) with a vise.
2. Remove the nozzle holder (1), and take out parts inside.

(When reassembling)

- Assemble the nozzle in clean fuel oil.
- Install the push rod (4), noting its direction.
- After assembling the nozzle, be sure to adjust the fuel injection pressure.

Tightening torque	Nozzle holder	34.3 to 39.2 N·m 3.5 to 4.0 kgf·m 25.3 to 28.9 lbf·ft
	Overflow pipe nut	19.6 to 24.5 N·m 2.0 to 2.5 kgf·m 14.5 to 18.1 lbf·ft
	Nozzle holder assembly	49.0 to 68.6 N·m 5.0 to 7.0 kgf·m 36.2 to 50.6 lbf·ft

- (1) Nozzle Holder (5) Distance Piece
 (2) Adjusting Washer (6) Nozzle Piece
 (3) Nozzle Spring (7) Nozzle Retaining Nut
 (4) Push Rod

W1062045

(7) Starter

■ Electromagnetic Drive Type

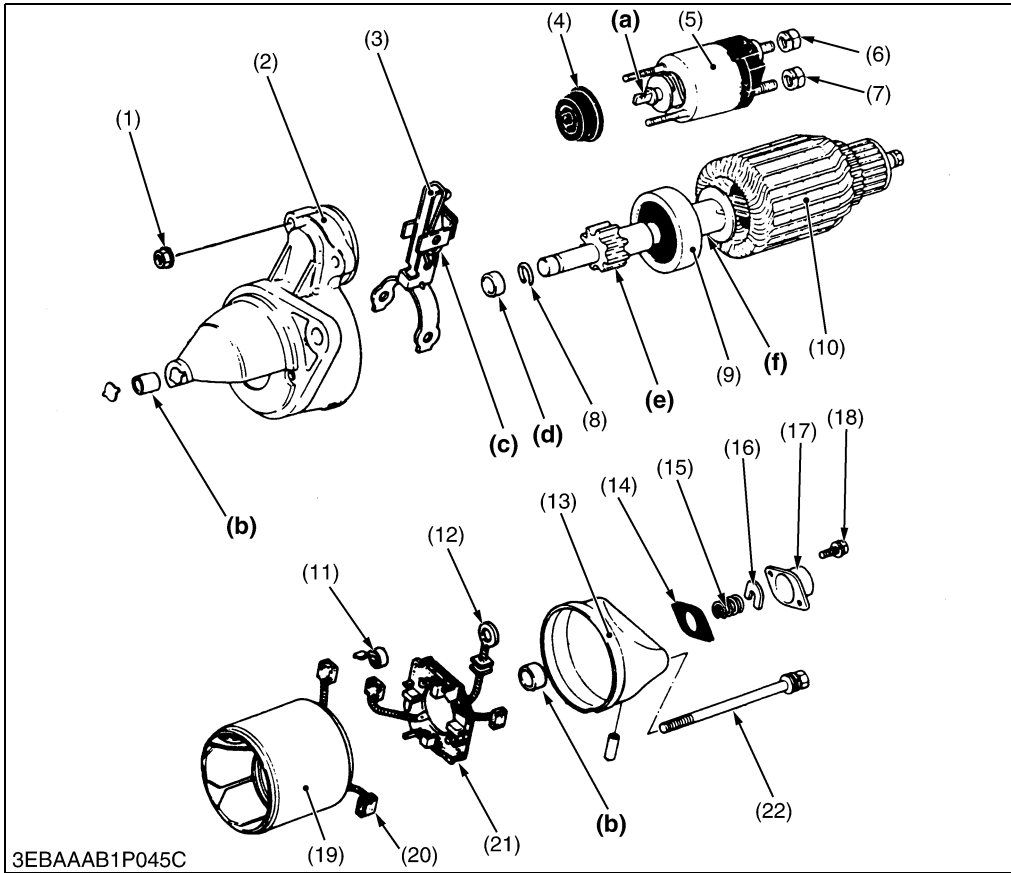

- (1) Solenoid Switch Mounting Nut
- (2) Starter Drive Housing
- (3) Drive Lever
- (4) Gasket
- (5) Solenoid Switch
- (6) **B** Terminal Nut
- (7) **C** Terminal Nut
- (8) Snap Ring
- (9) Overrunning Clutch
- (10) Armature
- (11) Brush Spring
- (12) Connecting Lead
- (13) Rear End Frame
- (14) Gasket
- (15) Brake Spring
- (16) Brake Shoe
- (17) End Frame Cap
- (18) Screw
- (19) Yoke
- (20) Brush
- (21) Brush Holder
- (22) Through Bolt

W1037593

1. Remove the **C** terminal nut (7), and disconnect the connecting lead (12).
2. Remove the solenoid switch mounting nuts (1), and remove the solenoid switch (5).
3. Remove the end frame cap (17).
4. Remove the brake shoe (16), brake spring (15) and gasket (14).
5. Remove the through bolts (22), and remove the rear end frame (13).
6. Remove the brush from the brush holder while holding the spring up.
7. Remove the brush holder (21).
8. Draw out the yoke (19) from the starter drive housing (2).
9. Draw out the armature (10) with the drive lever (3).

■ NOTE

- Do not damage to the brush and commutator.

(When reassembling)

- Apply grease (DENSO.CO.LTD. No. 50 or equivalent) to the parts indicated in the figure.
 - Joint of solenoid switch (**a**)
 - Bushing (**b**)
 - Drive lever (**c**)
 - Collar (**d**)
 - Teeth of pinion gear (**e**)
 - Armature shaft (**f**)

Tightening torque	B terminal nut	7.8 to 9.8 N·m 0.8 to 1.0 kgf·m 5.8 to 7.2 lbf·ft
-------------------	-----------------------	---

W1012736

■ Planetary Gear Reduction Type

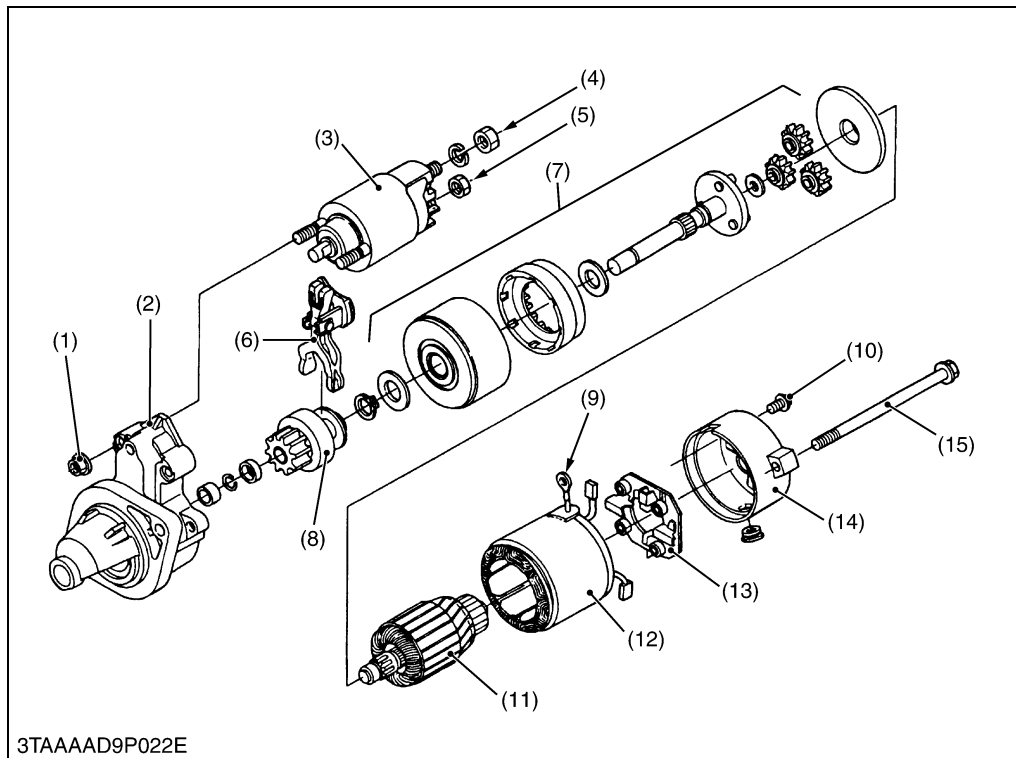

- (1) Magnetic Switch Mounting Nut
- (2) Housing
- (3) Magnetic Switch
- (4) **B** Terminal Nut
- (5) **C** Terminal Nut
- (6) Drive Lever
- (7) Shaft Assembly
- (8) Overrunning Clutch
- (9) Connecting Lead
- (10) Mounting Screw
- (11) Armature
- (12) Yoke
- (13) Brush Holder
- (14) Rear End Frame
- (15) Through Bolt

W1222714

3TAAAD9P022E

1. Remove the **C** terminal nut (5), and disconnect the connecting lead (9).
2. Remove the magnetic switch mounting nuts (1), and remove the magnetic switch (3) from the housing (2).
3. Remove the through bolts (15) and mounting screw (10), and remove the rear end frame (14).
4. Remove the brush from the brush holder while holding the spring up.
5. Remove the brush holder (13).
6. Draw out the armature (11) and yoke (12) from the housing.
7. Draw out the shaft assembly (7) with the drive lever (6) and overrunning clutch (8) from the housing.

(When reassembling)

Tightening torque	B terminal nut	5.9 to 11.8 N·m 0.6 to 1.2 kgf·m 4.3 to 8.7 lbf·ft
-------------------	-----------------------	--

W1012736

[4] SERVICING

(1) Cylinder Head and Valves

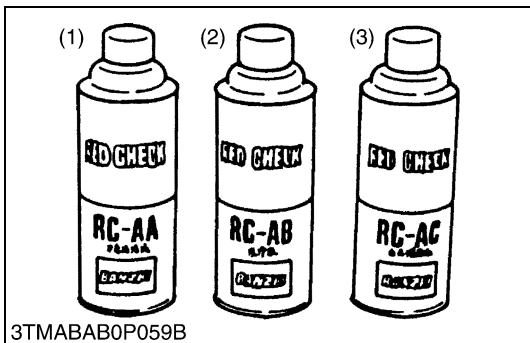
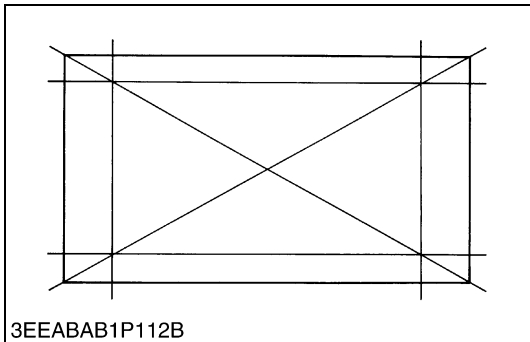
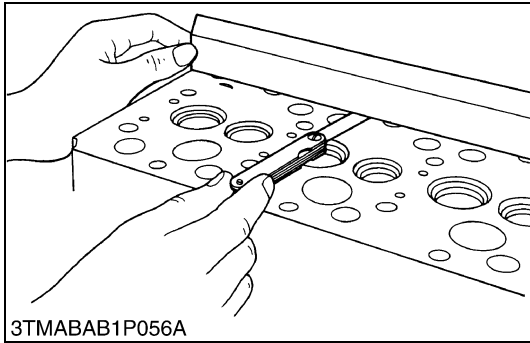

Cylinder Head Surface Flatness

1. Clean the cylinder head surface.
2. Place a straightedge on the cylinder head's four sides and two diagonal as shown in the figure.
3. Measure the clearance with a thickness gauge.
4. If the measurement exceeds the allowable limit, correct it with a surface grinder.

■ IMPORTANT

- Do not place the straightedge on the combustion chamber.

Cylinder head surface flatness	Allowable limit	0.05 mm 0.0020 in.
--------------------------------	-----------------	-----------------------

W1027737

Cylinder Head Flaw

1. Prepare an air spray red check (Code No. 07909-31371).
2. Clean the surface of the cylinder head with detergent (2).
3. Spray the cylinder head surface with the red permeative liquid (1). Leave it five to ten minutes after spraying.
4. Wash away the red permeative liquid on the cylinder head surface with the detergent (2).
5. Spray the cylinder head surface with white developer (3).
6. If flawed, it can be identified as red marks.

- (1) Red Permeative Liquid
(2) Detergent

- (3) White Developer

W1076542

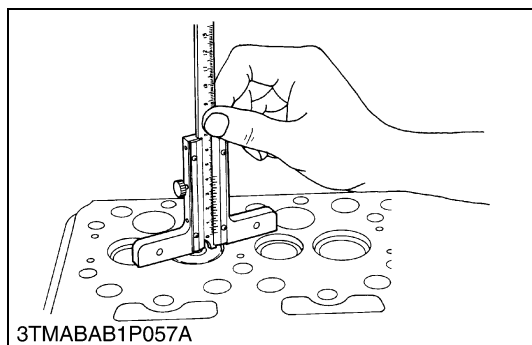

Valve Recessing

1. Clean the cylinder head surface, valve face and valve seat.
2. Insert the valve into the valve guide.
3. Measure the valve recessing with a depth gauge.
4. If the measurement exceeds the allowable limit, replace the valve.
5. If it still exceeds the allowable limit after replacing the valve, replace the cylinder head.

Valve recessing (Intake and exhaust)	Factory spec.	0.10 (protrusion) to 0.10 (recessing) mm 0.0039 (protrusion) to 0.0039 (recessing) in.
	Allowable limit	0.30 (recessing) mm 0.0118 (recessing) in.

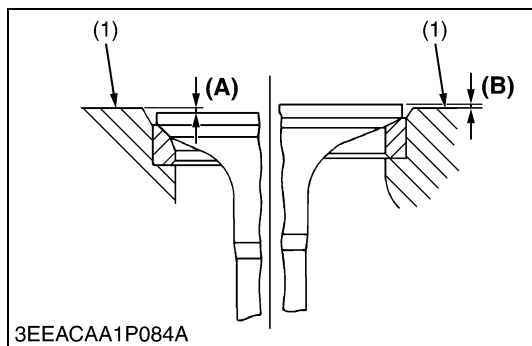

(1) Cylinder Head Surface

(A) Recessing
(B) Protrusion

W10768800

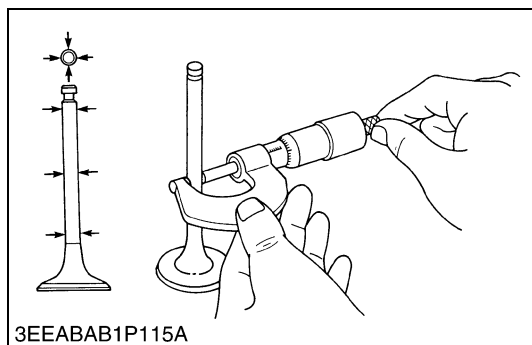

Clearance between Valve Stem and Valve Guide

1. Remove carbon from the valve guide section.
2. Measure the valve stem O.D. with an outside micrometer.
3. Measure the valve guide I.D. with a small hole gauge, and calculate the clearance.
4. If the clearance exceeds the allowable limit, replace the valves.
If it still exceeds the allowable limit, replace the valve guide.

Clearance between valve stem and valve guide	Factory spec.	0.030 to 0.057 mm 0.00118 to 0.00224 in.
	Allowable limit	0.10 mm 0.0039 in.

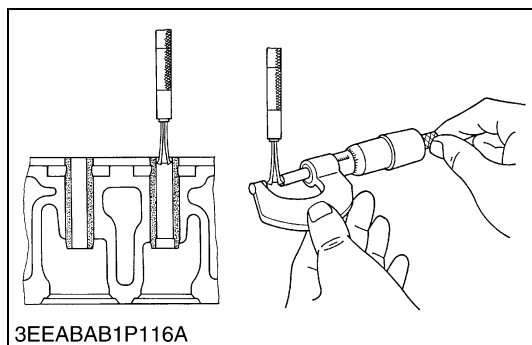

Valve stem O.D.	Factory spec.	5.968 to 5.980 mm 0.23496 to 0.23543 in.
Valve guide I.D.	Factory spec.	6.010 to 6.025 mm 0.23661 to 0.23720 in.

W1031174

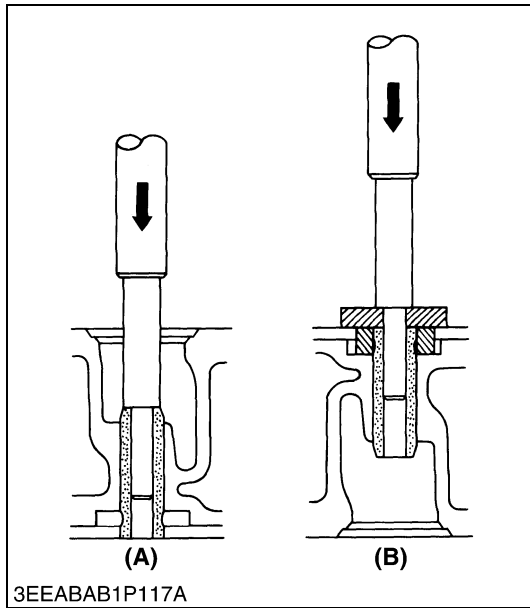

Replacing Valve Guide

(When removing)

1. Press out the used valve guide using a valve guide replacing tool. (Refer to “SPECIAL TOOLS”.)

(When installing)

1. Clean a new valve guide and valve guide bore, and apply engine oil to them.
2. Press in a new valve guide using a valve guide replacing tool.
3. Ream precisely the I.D. of the valve guide to the specified dimension.

Valve guide I.D. (Intake and exhaust)	Factory spec.	6.010 to 6.025 mm 0.23661 to 0.23720 in.
--	---------------	---

IMPORTANT

- Do not hit the valve guide with a hammer during replacement.

(A) When Removing

(B) When Installing

W10314690

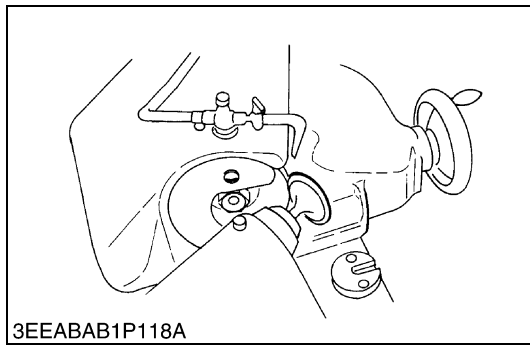

Correcting Valve and Valve Seat

NOTE

- Before correcting the valve and seat, check the valve stem and the I.D. of valve guide section, and repair them if necessary.
- After correcting the valve seat, be sure to check the valve recessing.

1) Correcting Valve

1. Correct the valve with a valve refacer.

Valve face angle	Factory spec.	0.785 rad 45 °
------------------	---------------	-------------------

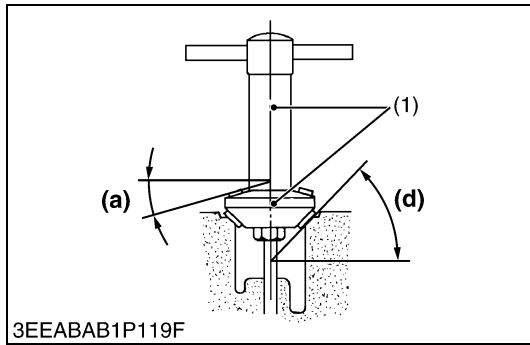

2) Correcting Valve Seat

1. Slightly correct the seat surface with a 0.785 rad (45 °) valve seat cutter (Code No. 07909-33102).
2. Fitting the valve, check the contact position of the valve face and seat surface with prussian blue. (Visual check) [If the valve has been used for a long period, the seat tends to come in contact with the upper side of the valve face.]
3. Grind the upper surface of the seat with a 0.262 rad (15 °) valve seat cutter until the valve seat touches to the center of the valve face (so that (a) equals (b) as shown in the figure.).
4. Grind the seat with a 0.785 rad (45 °) valve seat cutter again, and visually recheck the contact between the valve and seat.
5. Repeat steps 3 and 4 until the correct contact is achieved.
6. Continue lapping until the seated rate becomes more than 70 % of the total contact area.

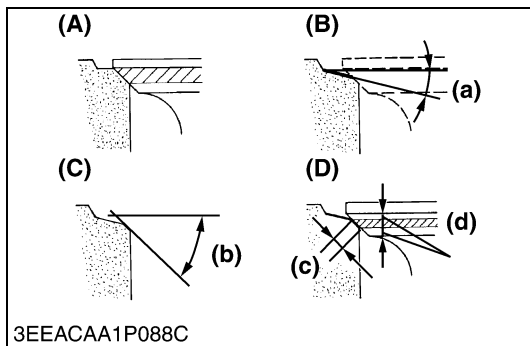

Valve seat angle	Factory spec.	0.785 rad 45 °
------------------	---------------	-------------------

(1) Valve Seat Cutter

(a) 0.262 rad (15 °)

(b) 0.785 rad (45 °)

(A) Check Contact

(c) Valve Seat Width

(B) Correct Seat Width

(d) Identical Dimensions

(C) Correct Seat Surface

(D) Check Contact

W10283500



Valve Lapping

1. Apply compound evenly to the valve lapping surface.
2. Insert the valve into the valve guide. Lap the valve onto its seat with a valve flapper or screwdriver.
3. After lapping the valve, wash the compound away and apply oil, then repeat valve lapping with oil.
4. Apply prussian blue to the contact surface to check the seated rate. If it is less than 70 %, repeat valve lapping again.

IMPORTANT

- When valve lapping is performed, be sure to check the valve recessing and adjust the valve clearance after assembling the valve.

- (1) Correct (3) Incorrect
 (2) Incorrect

W10288140

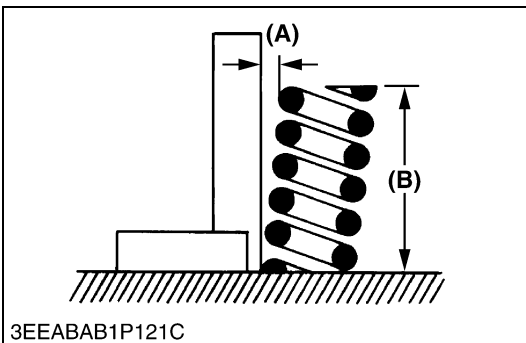
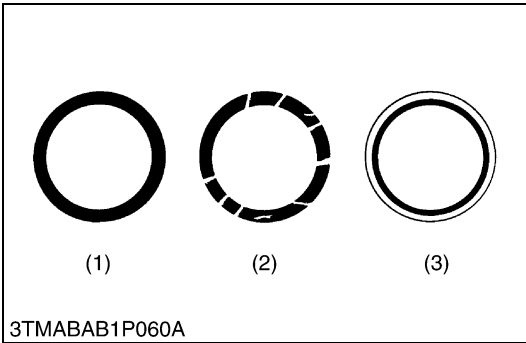

Free Length and Tilt of Valve Spring

1. Measure the free length (B) of valve spring with vernier calipers. If the measurement is less than the allowable limit, replace it.
2. Put the valve spring on a surface plate, place a square on the side of the valve spring.
3. Check to see if the entire side is in contact with the square. Rotate the valve spring and measure the maximum tilt (A). If the measurement exceeds the allowable limit, replace it.
4. Check the entire surface of the valve spring for scratches. If there is any defect, replace it.

Tilt (A)	Allowable limit	1.2 mm 0.047 in.
Free length (B)	Factory spec.	31.3 to 31.8 mm 1.232 to 1.252 in.
	Allowable limit	28.4 mm 1.118 in.

(A) Free Length (B) Tilt

W11157830

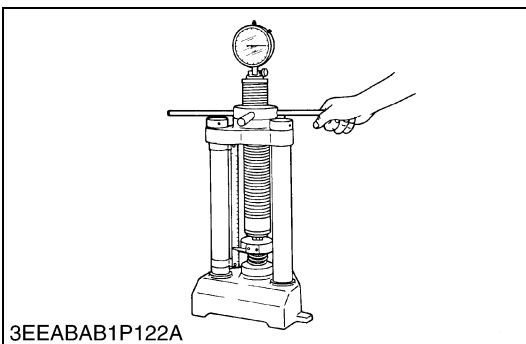

Valve Spring Setting Load

1. Place the valve spring on a tester and compress it to the same length it is actually compressed the engine.
2. Read the compression load on the gauge.
3. If the measurement is less than the allowable limit, replace it.

Setting load / Setting length	Factory spec.	64.7 N / 27.0 mm 6.6 kgf / 27.0 mm 14.6 lbf / 1.063 in.
	Allowable limit	54.9 N / 27.0 mm 5.6 kgf / 27.0 mm 12.3 lbf / 1.063 in.

W11177330

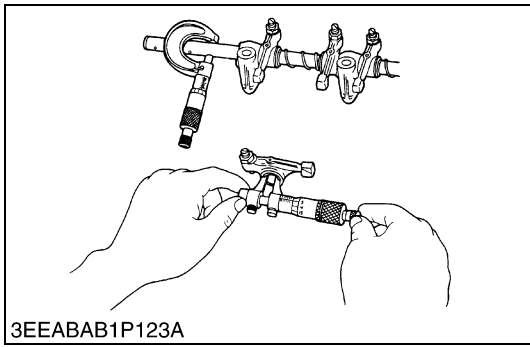

3EEABAB1P123A

Oil Clearance between Rocker Arm and Rocker Arm Shaft

1. Measure the rocker arm shaft O.D. with an outside micrometer.
2. Measure the rocker arm I.D. with an inside micrometer, and then calculate the oil clearance.
3. If the oil clearance exceeds the allowable limit, replace the rocker arm and measure the oil clearance again. If it still exceeds the allowable limit, replace also the rocker arm shaft.

Oil clearance between rocker arm and rocker arm shaft	Factory spec.	0.016 to 0.045 mm 0.00063 to 0.00177 in.
	Allowable limit	0.15 mm 0.0059 in.

Rocker arm shaft O.D.	Factory spec.	10.473 to 10.484 mm 0.41232 to 0.41276 in.
Rocker arm I.D.	Factory spec.	10.500 to 10.518 mm 0.41339 to 0.41410 in.

W11199710

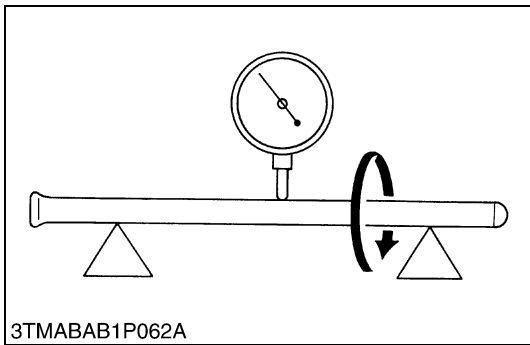

3TMABAB1P062A

Push Rod Alignment

1. Place the push rod on V blocks.
2. Measure the push rod alignment.
3. If the measurement exceeds the allowable limit, replace the push rod.

Push rod alignment	Allowable limit	0.25 mm 0.0098 in.
--------------------	-----------------	-----------------------

W11220210

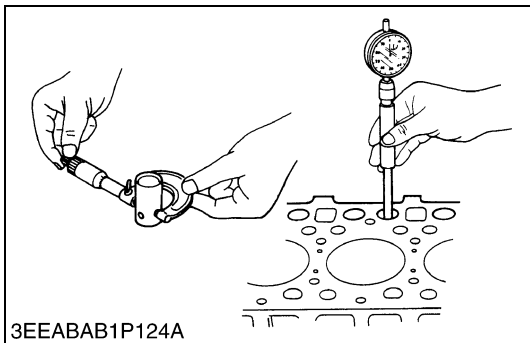

3EEABAB1P124A

Oil Clearance between Tappet and Tappet Guide Bore

1. Measure the tappet O.D. with an outside micrometer.
2. Measure the I.D. of the tappet guide bore with a cylinder gauge, and calculate the oil clearance.
3. If the oil clearance exceeds the allowable limit or the tappet is damaged, replace the tappet.

Oil clearance between tappet and tappet guide bore	Factory spec.	0.016 to 0.052 mm 0.00063 to 0.00205 in.
	Allowable limit	0.10 mm 0.0039 in.

Tappet O.D.	Factory spec.	17.966 to 17.984 mm 0.70732 to 0.70803 in.
Tappet guide bore I.D.	Factory spec.	18.000 to 18.018 mm 0.70866 to 0.70937 in.

W11231410

(2) Timing Gears, Camshaft and Fuel Camshaft

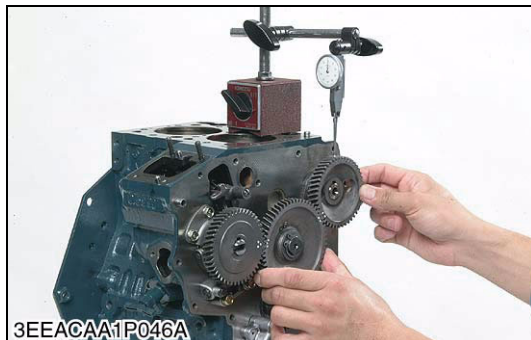

Timing Gear Backlash

1. Set a dial indicator (lever type) with its tip on the gear tooth.
2. Move the gear to measure the backlash, holding its mating gear.
3. If the backlash exceeds the allowable limit, check the oil clearance of the shaft and the gear.
4. If the oil clearance is not proper, replace the gear.

Backlash between idle gear and crank gear	Factory spec.	0.043 to 0.124 mm 0.00169 to 0.00488 in.
	Allowable limit	0.15 mm 0.0059 in.

Backlash between idle gear and cam gear	Factory spec.	0.047 to 0.123 mm 0.00185 to 0.00484 in.
	Allowable limit	0.15 mm 0.0059 in.

Backlash between idle gear and injection pump gear	Factory spec.	0.046 to 0.124 mm 0.00181 to 0.00488 in.
	Allowable limit	0.15 mm 0.0059 in.

Backlash between oil pump drive gear and crank gear	Factory spec.	0.041 to 0.123 mm 0.00161 to 0.00484 in.
	Allowable limit	0.15 mm 0.0059 in.

W11264830

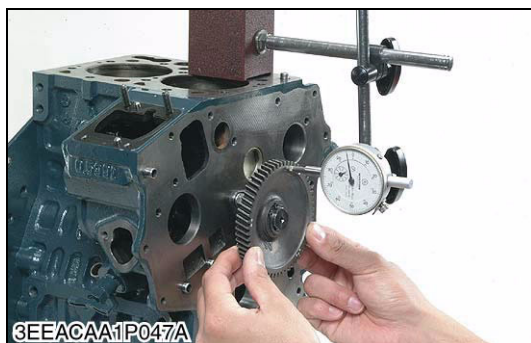

Idle Gear Side Clearance

1. Set a dial indicator with its tip on the idle gear.
2. Measure the side clearance by moving the idle gear to the front and rear.
3. If the measurement exceeds the allowable limit, replace the idle gear collar.

Idle gear side clearance	Factory spec.	0.20 to 0.46 mm 0.0079 to 0.0180 in.
	Allowable limit	0.60 mm 0.0236 in.

W11286770



Camshaft Side Clearance

1. Set a dial indicator with its tip on the camshaft.
2. Measure the side clearance by moving the cam gear to the front and rear.
3. If the measurement exceeds the allowable limit, replace the camshaft stopper.

Camshaft side clearance	Factory spec.	0.15 to 0.31 mm 0.0059 to 0.0122 in.
	Allowable limit	0.50 mm 0.0197 in.

W11299720

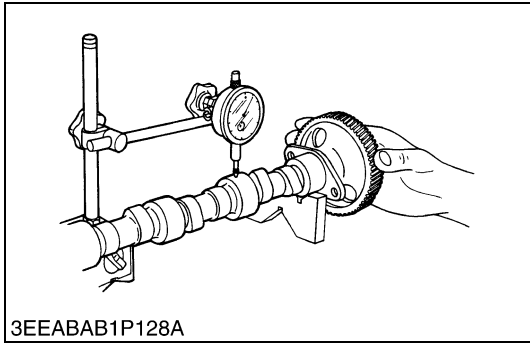

Camshaft Alignment

1. Support the camshaft with V blocks on the surface plate at both end journals.
2. Set a dial indicator with its tip on the intermediate journal.
3. Measure the camshaft alignment.
4. If the measurement exceeds the allowable limit, replace the camshaft.

Camshaft alignment	Allowable limit	0.01 mm 0.0004 in.
--------------------	-----------------	-----------------------

W11312720

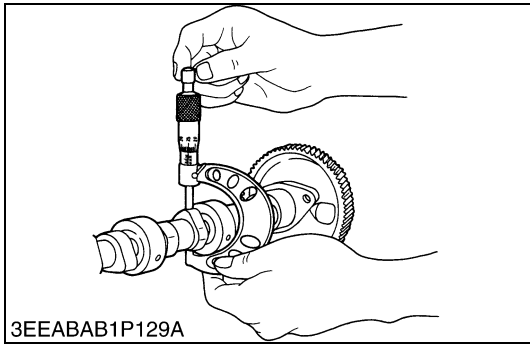

Cam Height

1. Measure the height of the cam at its highest point with an outside micrometer.
2. If the measurement is less than the allowable limit, replace the camshaft.

Cam height of intake and exhaust	Factory spec.	26.88 mm 1.0583 in.
	Allowable limit	26.83 mm 1.0563 in.

W11324040



Oil Clearance of Camshaft Journal

1. Measure the camshaft journal O.D. with an outside micrometer.
2. Measure the cylinder block bore I.D. for camshaft with a inside micrometer, and calculate the oil clearance.
3. If the oil clearance exceeds the allowable limit, replace the camshaft.

Oil clearance of camshaft journal	Factory spec.	0.050 to 0.091 mm 0.00197 to 0.00358 in.
	Allowable limit	0.15 mm 0.0059 in.

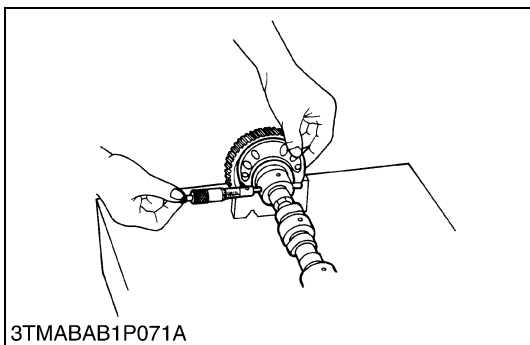

Camshaft journal O.D.	Factory spec.	32.934 to 32.950 mm 1.29661 to 1.29724 in.
Camshaft Bearing I.D. (Cylinder block bore I.D.)	Factory spec.	33.000 to 33.025 mm 1.29921 to 1.30020 in.

W11335580

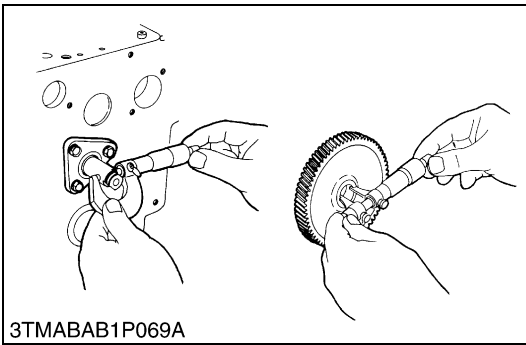

3TMABAB1P069A

Oil Clearance between Idle Gear Shaft and Idle Gear Bushing

1. Measure the idle gear shaft O.D. with an outside micrometer.
2. Measure the idle gear bushing I.D. with an inside micrometer, and calculate the oil clearance.
3. If the oil clearance exceeds the allowable limit, replace the bushing.
4. If it still exceeds the allowable limit, replace the idle gear shaft.

Oil clearance between idle gear shaft and idle gear bushing	Factory spec.	0.020 to 0.084 mm 0.00079 to 0.00331 in.
	Allowable limit	0.10 mm 0.0039 in.

Idle gear shaft O.D.	Factory spec.	19.967 to 19.980 mm 0.78610 to 0.78661 in.
Idle gear bushing I.D.	Factory spec.	20.000 to 20.051 mm 0.78740 to 0.78941 in.

W11356150

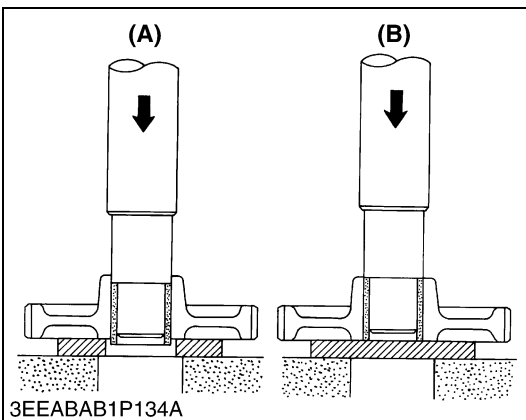

3EEABAB1P134A

Replacing Idle Gear Bushing

(When removing)

1. Press out the used idle gear bushing using an idle gear bushing replacing tool. (Refer to "SPECIAL TOOLS".)

(When installing)

1. Clean a new idle gear bushing and idle gear bore, and apply engine oil to them.
2. Press in a new bushing using an idle gear bushing replacing tool, until it is flush with the end of the idle gear.

(A) When Removing

(B) When Installing

W11373220

(3) Piston and Connecting Rod

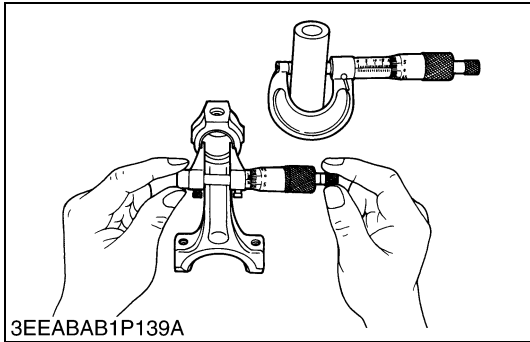
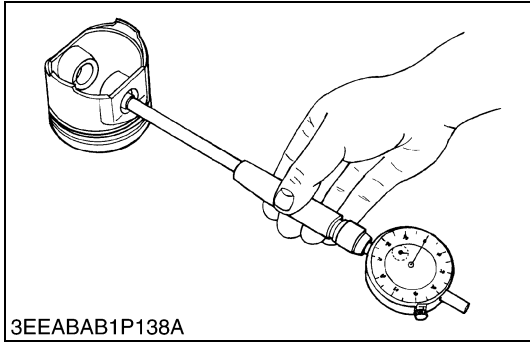

Piston Pin Bore I.D.

1. Measure the piston pin bore I.D. in both the horizontal and vertical directions with a cylinder gauge.
2. If the measurement exceeds the allowable limit, replace the piston.

Piston pin bore I.D.	Factory spec.	20.000 to 20.013 mm 0.78740 to 0.78791 in.
	Allowable limit	20.05 mm 0.7894 in.

W11406200

Oil Clearance between Piston Pin and Small End Bushing

1. Measure the piston pin O.D. where it contacts the bushing with an outside micrometer.
2. Measure the small end bushing I.D. with an inside micrometer, and calculate the oil clearance.
3. If the oil clearance exceeds the allowable limit, replace the bushing. If it still exceeds the allowable limit, replace the piston pin.

Oil clearance between piston pin and small end bushing	Factory spec.	0.014 to 0.038 mm 0.00055 to 0.00150 in.
	Allowable limit	0.10 mm 0.0039 in.

Piston pin O.D.	Factory spec.	20.002 to 20.011 mm 0.78748 to 0.78783 in.
Small end bushing I.D.	Factory spec.	20.025 to 20.040 mm 0.78839 to 0.78897 in.

W11420110

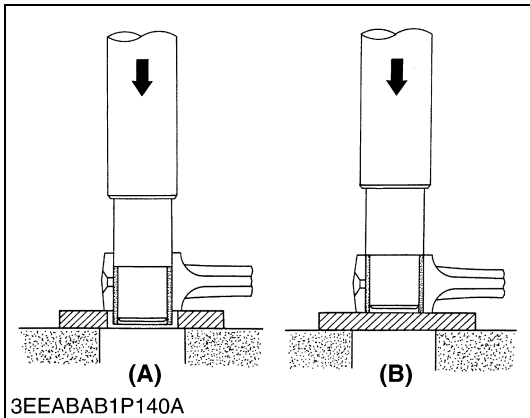

Replacing Small End Bushing

(When removing)

1. Press out the used bushing using a small end bushing replacing tool. (Refer to "SPECIAL TOOLS")

(When installing)

1. Clean a new small end bushing and small end hole, and apply engine oil to them.
2. Using a small end bushing replacing tool, press in a new bushing (service parts) taking care to see that the position of the connecting rod oil hole matches the bushing hole.

[Servicing parts dimension]

Oil clearance between piston pin and small end bushing (Spare parts)	Factory spec.	0.015 to 0.075 mm 0.00059 to 0.00295 in.
	Allowable limit	0.15 mm 0.0059 in.

Small end bushing I.D. (Spare parts)	Factory spec.	20.026 to 20.077 mm 0.78843 to 0.79043 in.
--------------------------------------	---------------	---

- (1) Seam
- (2) Oil Hole

- (A) When Removing**
- (B) When Installing**
- (a) 0.785 rad (45°)**

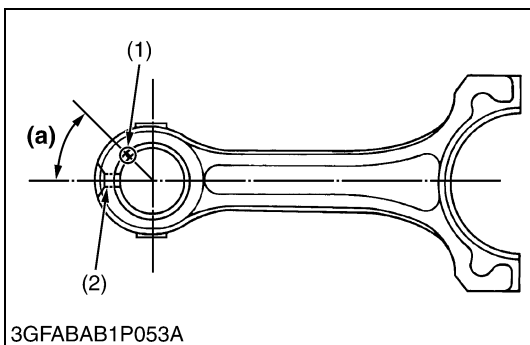

W11437590

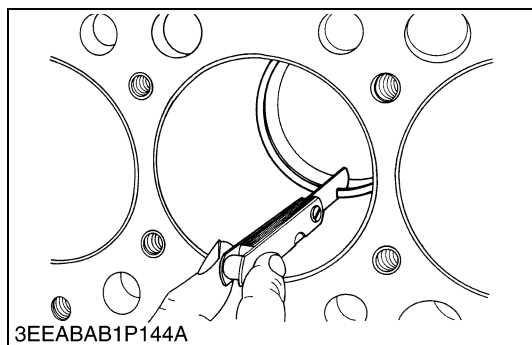

Piston Ring Gap

1. Insert the piston ring into the lower part of the cylinder (the least worn out part) with a piston ring compressor and piston.
2. Measure the ring gap with a feeler gauge.
3. If the measurement exceeds the allowable limit, replace the piston ring.

Piston ring gap	Top ring	Factory spec.	0.15 to 0.30 mm 0.0059 to 0.0118 in.
		Allowable limit	1.20 mm 0.0472 in.
	Second ring	Factory spec.	0.30 to 0.45 mm 0.0118 to 0.0177 in.
		Allowable limit	1.20 mm 0.0472 in.
	Oil ring	Factory spec.	0.15 to 0.30 mm 0.0059 to 0.0118 in.
		Allowable limit	1.20 mm 0.0472 in.

W11466710

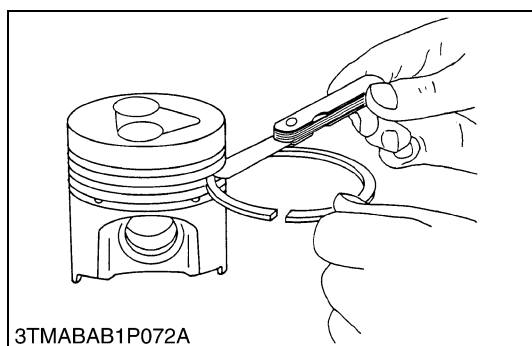

Clearance between Piston Ring and Piston Ring Groove

1. Clean the rings and the ring grooves, and install each ring in its groove.
2. Measure the clearance between the ring and the groove with a feeler gauge.
3. If the clearance exceeds the allowable limit, replace the piston ring.
4. If the clearance still exceeds the allowable limit with new ring, replace the piston.

Clearance between piston ring and piston ring groove	Second ring	Factory spec.	0.090 to 0.120 mm 0.00354 to 0.00472 in.
		Allowable limit	0.15 mm 0.0059 in.
	Oil ring	Factory spec.	0.04 to 0.08 mm 0.0016 to 0.0031 in.
		Allowable limit	0.15 mm 0.0059 in.

W11485500

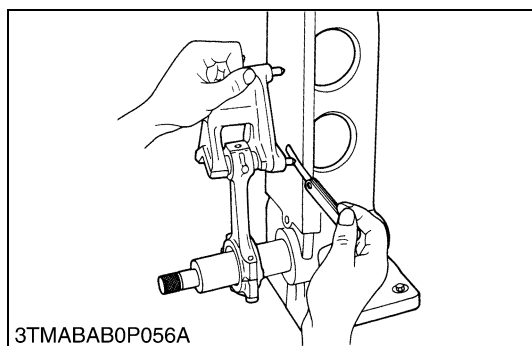

Connecting Rod Alignment

1. Remove the crankpin bearing, and install the connecting rod cap.
2. Install the piston pin in the connecting rod.
3. Install the connecting rod on the connecting rod alignment tool (Code No. 07909-31661).
4. Put a gauge over the piston pin, and move it against the face plate.
5. If the gauge does not fit squarely against the face plate, measure the space between the pin of the gauge and the face plate.
6. If the measurement exceeds the allowable limit, replace the connecting rod.

Space between gauge pin face plate	Allowable limit	0.05 mm 0.0020 in.
------------------------------------	-----------------	-----------------------

W10314620

(4) Crankshaft

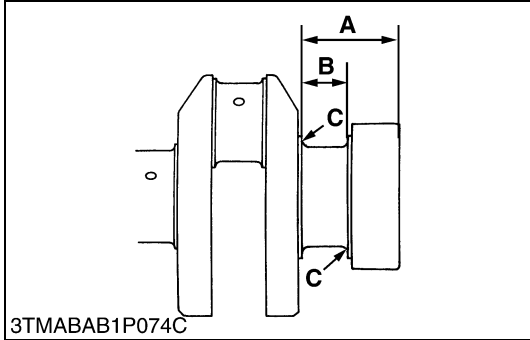
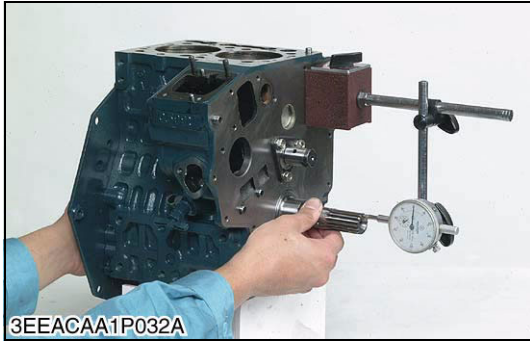

Crankshaft Side Clearance

1. Set a dial indicator with its tip on the end of the crankshaft.
2. Measure the side clearance by moving the crankshaft to the front and rear.
3. If the measurement exceeds the allowable limit, replace the thrust bearings.
4. If the same size bearing is useless because of the crankshaft journal wear, replace it with an oversize one referring to the table and figure.

Crankshaft side clearance	Factory spec.	0.15 to 0.31 mm 0.0059 to 0.0122 in.
	Allowable limit	0.50 mm 0.0197 in.

(Reference)

- Oversize thrust bearing

Oversize	Bearing	Code Number	Marking
0.2 mm 0.008 in.	Thrust bearing 1 02	15261-23950	020 OS
	Thrust bearing 2 02	15261-23970	020 OS
0.4 mm 0.016 in.	Thrust bearing 1 04	15261-23960	040 OS
	Thrust bearing 2 04	15261-23980	040 OS

- Oversize dimensions of crankshaft journal

Oversize	0.2 mm 0.008 in.	0.4 mm 0.016 in.
Dimension A	46.1 to 46.3 mm 1.815 to 1.823 in.	46.3 to 46.5 mm 1.823 to 1.831 in.
Dimension B	23.40 to 23.45 mm 0.9134 to 0.9154 in.	23.80 to 23.85 mm 0.9213 to 0.9232 in.
Dimension C	1.8 to 2.2 mm radius 0.071 to 0.087 in. radius	1.8 to 2.2 mm radius 0.071 to 0.087 in. radius
(0.8S)		
The crankshaft journal must be fine-finished to higher than ∇∇∇∇.		

W11586190

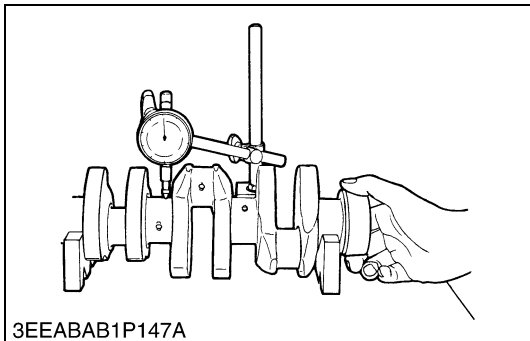

Crankshaft Alignment

1. Support the crankshaft with V blocks on the surface plate at both end journals.
2. Set a dial indicator with its tip on the intermediate journal.
3. Measure the crankshaft alignment.
4. If the measurement exceeds the allowable limit, replace the crankshaft.

Crankshaft alignment	Allowable limit	0.02 mm 0.0008 in.
----------------------	-----------------	-----------------------

W11613530

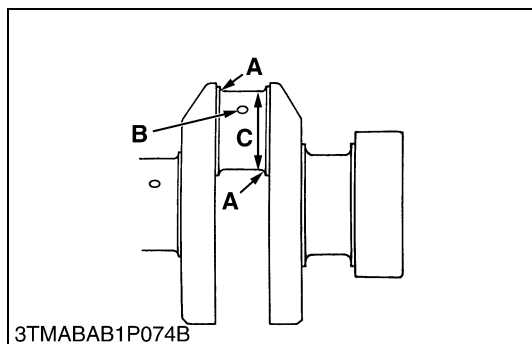
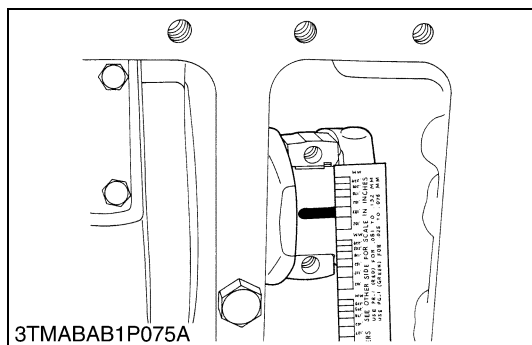

Oil Clearance between Crankpin and Crankpin Bearing

1. Clean the crankpin and crankpin bearing.
2. Put a strip of plastigauge on the center of the crankpin.
3. Install the connecting rod cap and tighten the connecting rod screws to the specified torque, and remove the cap again.
4. Measure the amount of the flattening with the scale, and get the oil clearance.
5. If the oil clearance exceeds the allowable limit, replace the crankpin bearing.
6. If the same size bearing is useless because of the crankpin wear, replace it with an undersize one referring to the table and figure.

■ **NOTE**

- **Never insert the plastigauge into the crankpin oil hole.**
- **Be sure not to move the crankshaft while the connecting rod screws are tightened.**

Oil clearance between crankpin and crankpin bearing	Factory spec.	0.020 to 0.051mm 0.00079 to 0.00201 in.
	Allowable limit	0.15 mm 0.0059 in.

Crankpin O.D.	Factory spec.	33.959 to 33.975 mm 1.33697 to 1.33760 in.
---------------	---------------	---

Crankpin bearing I.D.	Factory spec.	33.995 to 34.010 mm 1.33839 to 1.33898 in.
-----------------------	---------------	---

(Reference)

- Undersize crankpin bearing

Undersize	Bearing	Code Number	Marking
0.2 mm 0.008 in.	Crankpin bearing 02	15861-22970	020 US
0.4 mm 0.016 in.	Crankpin bearing 04	15861-20980	040 US

- Undersize dimensions of crankpin

Undersize	0.2 mm 0.008 in.	0.4 mm 0.016 in.
Dimension A	2.3 to 2.7 mm radius 0.091 to 0.106 in. radius	2.3 to 2.7 mm radius 0.091 to 0.106 in. radius
*Dimension B	1.0 to 1.5 mm relief 0.0394 to 0.0591 in. relief	1.0 to 1.5 mm relief 0.0394 to 0.0591 in. relief
Dimension C	33.759 to 33.775 mm dia. 1.32910 to 1.32973 in. dia.	33.559 to 33.575 mm dia. 1.32122 to 1.32185 in. dia.

(0.8S)

The crankpin must be fine-finished to higher than ∇∇∇∇.
 *Holes to be de-burred and edges rounded with 1.0 to 1.5 mm
 (0.0394 to 0.0591 in.) relief.

W11625390

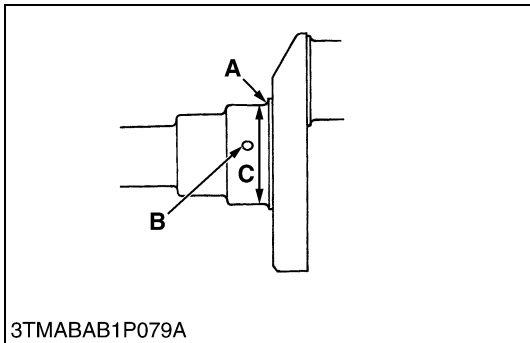
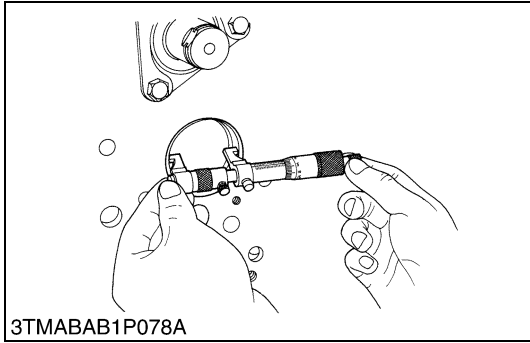
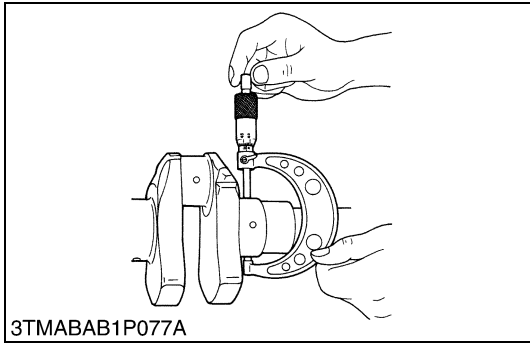

Oil Clearance between Crankshaft Journal and Crankshaft Bearing 1

1. Measure the O.D. of the crankshaft front journal with an outside micrometer.
2. Measure the I.D. of the crankshaft bearing 1 with an inside micrometer, and calculate the oil clearance.
3. If the oil clearance exceeds the allowable limit, replace the crankshaft bearing 1.
4. If the same size bearing is useless because of the crankshaft journal wear, replace it with an undersize one referring to the table and the figure.

Oil Clearance between crankshaft journal and crankshaft bearing 1	Factory spec.	0.034 to 0.106 mm 0.00134 to 0.00417 in.
	Allowable limit	0.20 mm 0.0079 in.

Crankshaft journal O.D.	Factory spec.	39.934 to 39.950 mm 1.57221 to 1.57284 in.
Crankshaft bearing 1 I.D.		39.984 to 40.040 mm 1.57417 to 1.57638 in.

(Reference)

- Undersize crankshaft bearing 1

Undersize	Bearing	Code Number	Marking
0.2 mm 0.008 in.	Crankshaft bearing 1 02	15861-23910	020 US
0.4 mm 0.016 in.	Crankshaft bearing 1 04	15861-23920	040 US

- Undersize dimensions of crankshaft journal

Undersize	0.2 mm 0.008 in.	0.4 mm 0.016 in.
Dimension A	1.8 to 2.2 mm radius 0.071 to 0.087 in. radius	1.8 to 2.2 mm radius 0.071 to 0.087 in. radius
*Dimension B	1.0 to 1.5 mm relief 0.0394 to 0.0591 in. relief	1.0 to 1.5 mm relief 0.0394 to 0.0591 in. relief
Dimension C	39.734 to 39.750 mm dia. 1.56433 to 1.56496 in. dia.	39.534 to 39.550 mm dia. 1.55646 to 1.55709 in. dia.

(0.8S)
The crankshaft journal must be fine-finished to higher than ▽▽▽▽.
*Holes to be de-burred and edges rounded with 1.0 to 1.5 mm (0.0394 to 0.0591 in.) relief.

W10323470

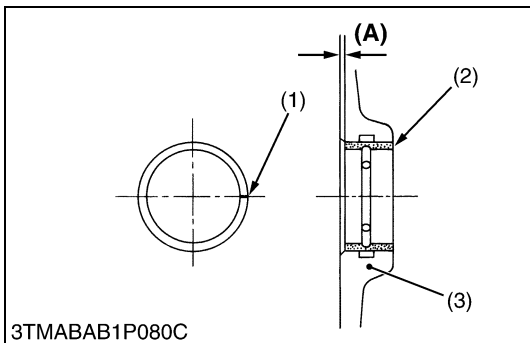

Replacing Crankshaft Bearing 1

(When removing)

1. Press out the used crankshaft bearing 1 using a crankshaft bearing 1 replacing tool. (Refer to "SPECIAL TOOLS".)

(When installing)

1. Clean a new crankshaft bearing 1 and crankshaft journal bore, and apply engine oil to them.
2. Using a crankshaft bearing 1 replacing tool, press in a new bearing 1 (2) so that its seam (1) directs toward the exhaust manifold side. (See figure.)

Dimension (A)	Factory spec.	0.0 to 0.3 mm 0.0 to 0.0118 in.
---------------	---------------	------------------------------------

- (1) Seam
- (2) Crankshaft Bearing 1
- (3) Cylinder Block

(A) Dimension

W10342000

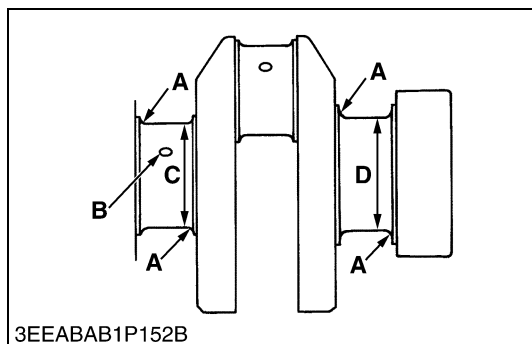
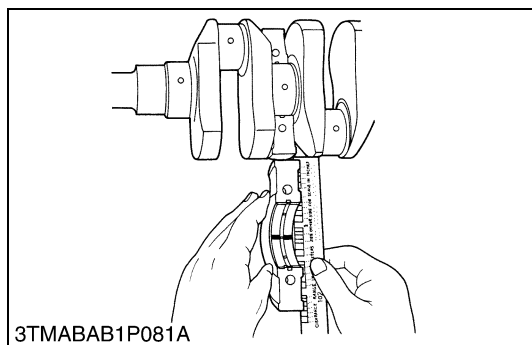

Oil Clearance between Crankshaft Journal and Crankshaft Bearing 2 and Crankshaft Bearing 3

1. Put a strip of plastigauge (Code No. 07909-30241) on the center of the journal.
2. Install the bearing case and tighten the bearing case screws 1 to the specified torque, and remove the bearing case again.
3. Measure the amount of the flattening with the scale, and get the oil clearance.
4. If the oil clearance exceeds the allowable limit, replace the crankshaft bearing 2 (crankshaft bearing 3).
5. If the same size bearing is useless because of the crankshaft journal wear, replace it with an undersize one referring to the table and figure.

NOTE

- Be sure not to move the crankshaft while the bearing case screws are tightened.

Oil clearance between crankshaft journal and crankshaft bearing 2 (crankshaft bearing 3)	Factory spec.	0.028 to 0.059 mm 0.00110 to 0.00232 in.
	Allowable limit	0.20 mm 0.0079 in.

Crankshaft journal O.D. (Flywheel side)	Factory spec.	43.934 to 43.950 mm 1.72968 to 1.73031 in.
Crankshaft bearing 2 I.D.	Factory spec.	43.978 to 43.993 mm 1.73142 to 1.73201 in.

Crankshaft journal O.D. (Intermediate)	Factory spec.	39.934 to 39.950 mm 1.57221 to 1.57284 in.
Crankshaft bearing 3 I.D.	Factory spec.	39.978 to 39.993 mm 1.57394 to 1.57453 in.

(Reference)

- Undersize crankshaft bearing 2 and 3

Oversize	Part Name	Marking
0.2 mm 0.008 in.	Crankshaft bearing 2 02	020 US
	Crankshaft bearing 3 02	020 OS
0.4 mm 0.016 in.	Crankshaft bearing 2 04	040 OS
	Crankshaft bearing 3 04	040 OS

- Undersize dimensions of crankshaft journal

Undersize	0.2 mm 0.008 in.	0.4 mm 0.016 in.
Dimension A	1.8 to 2.2 mm radius 0.071 to 0.087 in. radius	1.8 to 2.2 mm radius 0.071 to 0.087 in. radius
*Dimension B	1.0 to 1.5 mm relief 0.0394 to 0.0591 in. relief	1.0 to 1.5 mm relief 0.0394 to 0.0591 in. relief
Dimension C	39.734 to 39.750 mm dia. 1.56433 to 1.56496 in. dia.	39.534 to 39.550 mm dia. 1.55646 to 1.55709 in. dia.
Dimension D	43.734 to 43.750 mm dia. 1.72181 to 1.72244 in. dia.	43.534 to 43.550 mm dia. 1.71394 to 1.7147 in. dia.

(0.8S)
The crankshaft journal must be fine-finished to higher than ∇∇∇∇.
*Holes to be de-burred and edges rounded with 1.0 to 1.5 mm (0.0394 to 0.0591 in.) relief.

W10344030

(5) Cylinder

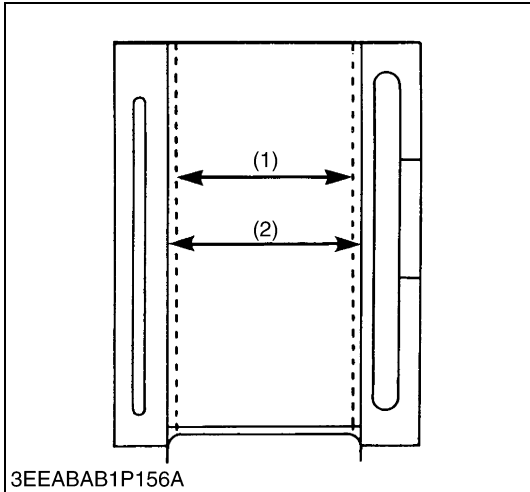
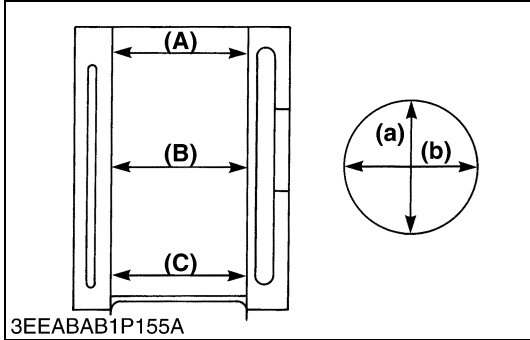
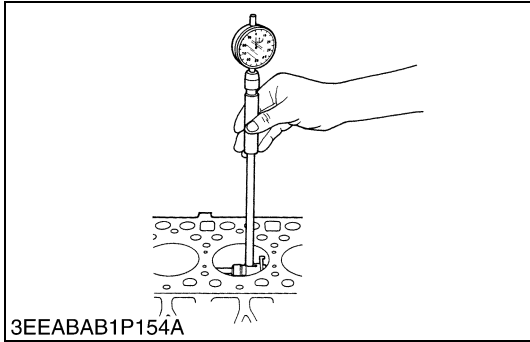

Cylinder Wear

1. Measure the cylinder liner I.D. at the six positions (see figure) with a cylinder gauge to find the maximum and minimum I.D.'s.
2. Get the difference (Maximum wear) between the maximum and the minimum I.D.'s.
3. If the wear exceeds the allowable limit, bore and hone to the oversize dimension. (Refer to **“Correcting Cylinder”**.)
4. Visually check the cylinder wall for scratches. If deep scratches are found, the cylinder should be bored. (Refer to **“Correcting Cylinder”**.)

Cylinder I.D.	Factory spec.	67.000 to 67.019 mm 2.63780 to 2.63854 in.
	Allowable limit	67.169 mm 2.64445 in.

- (A) Top
- (B) Middle
- (C) Bottom (Skirt)
- (a) Right-angled to Piston Pin
- (b) Piston Pin Direction

W10360060

Correcting Cylinder (Oversize)

1. When the cylinder is worn beyond the allowable limit, bore and hone it to the specified dimension.

Cylinder I.D. [Oversize]	Factory spec.	67.250 to 67.269 mm 2.64764 to 2.64839 in.
	Allowable limit	67.400 mm 2.65354 in.
Finishing	Hone to 2.2 to 3.0 μmRz. ▽▽▽ (0.000087 to 0.00012 in. Rz.)	

2. Replace the piston and piston rings with oversize ones.

Oversize	Part Name	Marking
0.25 mm 0.0098 in.	Piston	025
	Piston ring assembly	025

NOTE

- When the oversize cylinder is worn beyond the allowable limit, replace the cylinder block with a new one.

(1) Cylinder I.D. [Before Correction] (2) Cylinder I.D. [Oversize]

W10367470

(6) Oil Pump

3TAAAAD1P077A

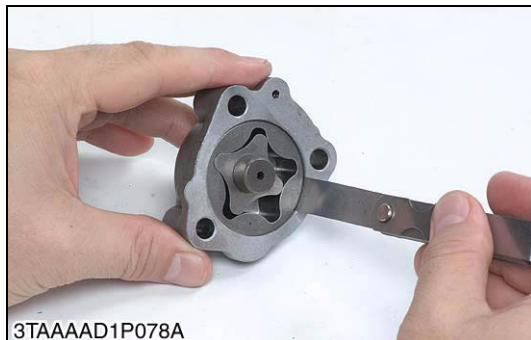

3TAAAAD1P078A

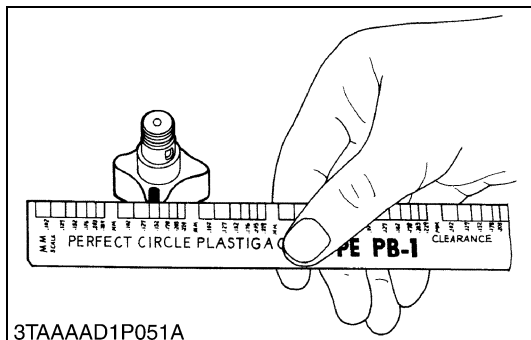

3TAAAAD1P051A

Rotor Lobe Clearance

1. Measure the clearance between lobes of the inner rotor and the outer rotor with a thickness gauge.
2. If the clearance exceeds the factory specifications, replace the oil pump rotor assembly.

Rotor lobe clearance	Factory spec.	0.03 to 0.14 mm 0.0012 to 0.0055 in.
----------------------	---------------	---

W10378950

Clearance between Outer Rotor and Pump Body

1. Measure the clearance between the outer rotor and the pump body with a thickness gauge.
2. If the clearance exceeds the factory specifications, replace the oil pump rotor assembly.

Clearance between outer rotor and pump body	Factory spec.	0.07 to 0.15 mm 0.0028 to 0.0059 in.
---	---------------	---

W10381420

Clearance between Rotor and Cover

1. Put a strip of plastigauge (Code No. 07909-30241) onto the rotor face with grease.
2. Install the cover and tighten the screws.
3. Remove the cover carefully, and measure the amount of the flattening with the scale and get the clearance.
4. If the clearance exceeds the factory specifications, replace oil pump rotor assembly.

Clearance between rotor and cover	Factory spec.	0.075 to 0.135 mm 0.00295 to 0.00531 in.
-----------------------------------	---------------	---

W10382660

(7) Starter

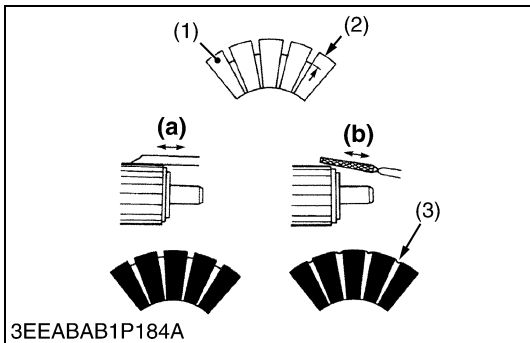
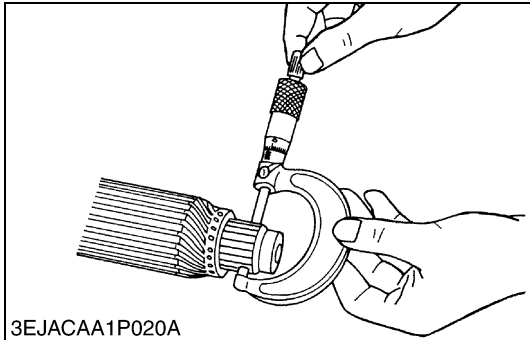
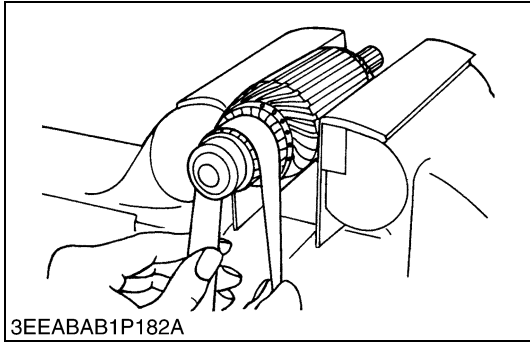

Commutator and Mica

1. Check the contact face of the commutator for wear, and grind the commutator with emery paper if it is slightly worn.
2. Measure the commutator O.D. with an outside micrometer at several points.
3. If the minimum O.D. is less than the allowable limit, replace the armature.
4. If the difference of the O.D.'s exceeds the allowable limit, correct the commutator on a lathe to the factory specification.
5. Measure the mica undercut.
6. If the undercut is less than the allowable limit, correct it with a saw blade and chamfer the segment edges.

Commutator O.D.	Factory spec.	Electromagnetic drive type	28.0 mm 1.102 in.
		Planetary gear reduction type	30.0 mm 1.181 in.
	Allowable limit	Electromagnetic drive type	27.0 mm 1.063 in.
		Planetary gear reduction type	29.0 mm 1.142 in.

Difference of O.D.'s	Factory spec.	Electromagnetic drive type	Less than 0.05 mm 0.002 in.
		Planetary gear reduction type	Less than 0.02 mm 0.0008 in.
	Allowable limit	Electromagnetic drive type	0.4 mm 0.016 in.
		Planetary gear reduction type	0.05 mm 0.0020 in.

Mica undercut	Factory spec.	0.50 to 0.80 mm 0.020 to 0.031 in.
	Allowable limit	0.20 mm 0.0079 in.

- (1) Segment
 (2) Undercut
 (3) Mica
- (a) Correct**
(b) incorrect

W1075277

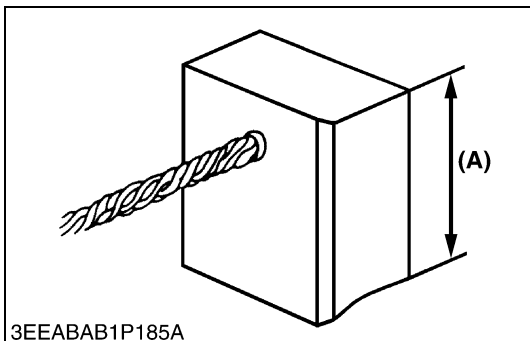

Brush Wear

1. If the contact face of the brush is dirty or dusty, clean it with emery paper.
2. Measure the brush length (A) with vernier calipers.
3. If the length is less than the allowable limit, replace the yoke assembly and brush holder.

Brush length (A)	Factory spec.	16.0 mm 0.630 in.
	Allowable limit	10.5 mm 0.413 in.

(A) Brush Length

W1075476

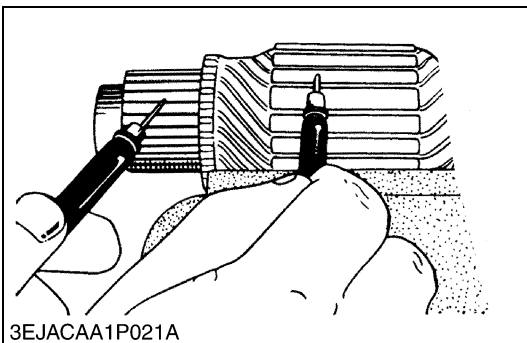

Armature Coil

1. Check the continuity across the commutator and armature coil core with an ohmmeter.
2. If it conducts, replace the armature.
3. Check the continuity across the segments of the commutator with an ohmmeter.
4. If it does not conduct, replace the armature.

W1075693

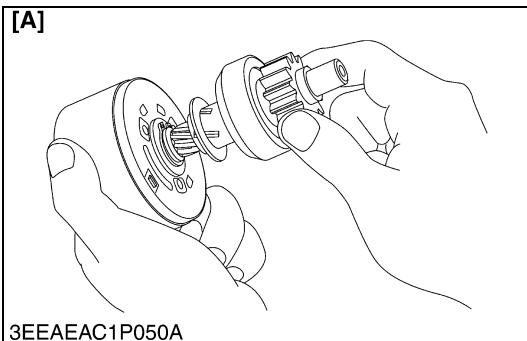
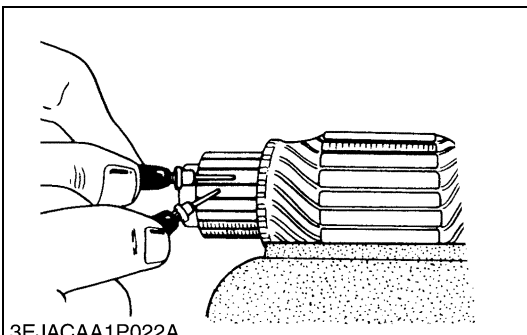

Overrunning Clutch

1. Check the pinion and if worn or damaged, replace the clutch assembly.
2. Check that the pinion turns freely and smoothly in the overrunning direction and does not slip in the cranking direction.
3. If the pinion slips or does not turn in both directions, replace the overrunning clutch assembly.

NOTE

- Do not wash off the grease in the overrunning clutch with the chemicals or oils.

[A] Electromagnetic Drive Type

[B] Planetary Gear Reduction Type

W1075769

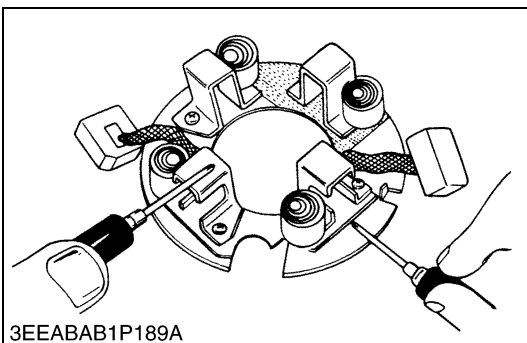
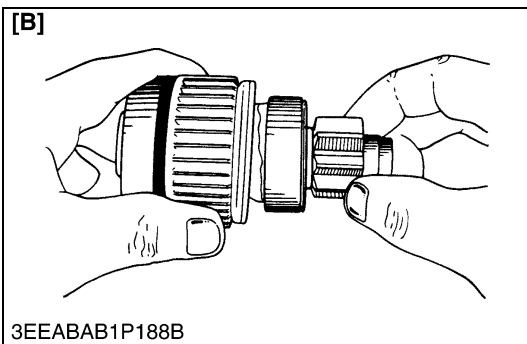

Brush Holder

1. Check the continuity across the brush holder and the holder support with an ohmmeter.
2. If it conducts, replace the brush holder.

W1076066

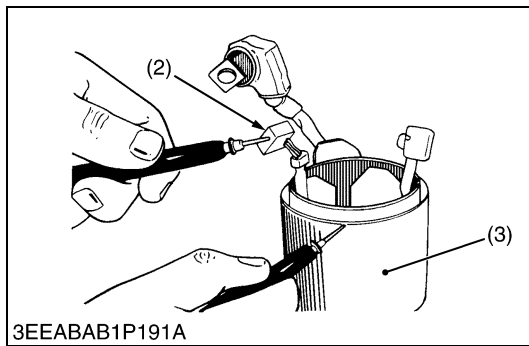
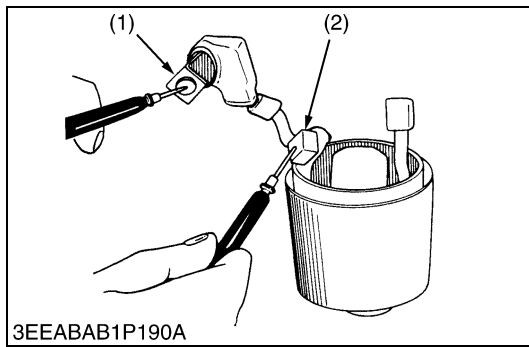
**Field Coil**

1. Check the continuity across the lead (1) and brush (2) with an ohmmeter.
2. If it does not conduct, replace the yoke assembly.
3. Check the continuity across the brush (2) and yoke (3) with an ohmmeter.
4. If it conducts, replace the yoke assembly.

(1) Lead
(2) Brush

(3) Yoke

W1076156

MECHANISM

CONTENTS

1. STRUCTURE	2-M1
2. AUTOMATIC VOLTAGE REGULATOR (A.V.R.).....	2-M2
3. EMERGENCY RELAY CIRCUIT.....	2-M5
[1] GENERAL.....	2-M5
[2] INSTRUCTIONS	2-M6
4. EARTH.....	2-M7
5. WIRING DIAGRAM	2-M8

1. STRUCTURE

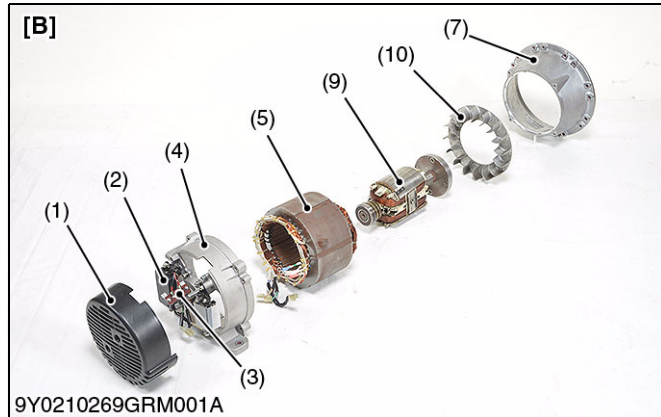
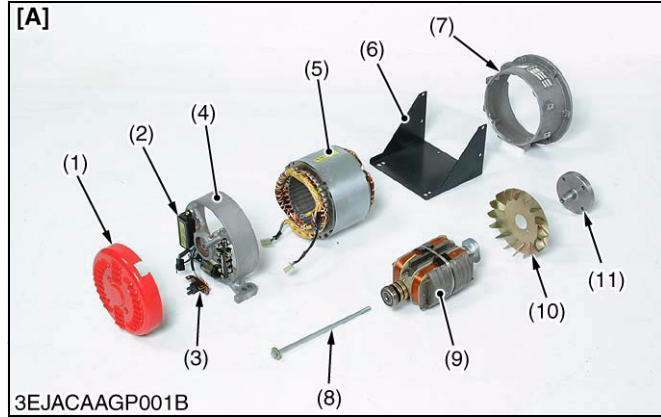

1. Stator Assembly

The main coil and sub coil for power generation are wound in the slots provided in the core.

The main coil generates the AC output and supplies A.V.R. assembly with a sensing voltage.

The sub coil, working as an excitation coil, supplies the field current to the rotor through A.V.R. assembly.

2. Rotor Assembly

The coils are wound to magnetize the entire core.

3. Brush Holder Assembly

The excitation voltage from sub coil of the stator assembly is applied to the rotor coil through the A.V.R. assembly rectifying circuit and the brush holder assembly.

4. Automatic Voltage Regulator (A.V.R.) Assembly

The A.V.R. assembly maintains the AC output voltage at a constant level.

- | | |
|---------------------------|--------------------|
| (1) Rear Cover | (8) Center Bolt |
| (2) A.V.R. Assembly | (9) Rotor Assembly |
| (3) Brush Holder Assembly | (10) Fan |
| (4) Rear Bracket | (11) PTO Shaft |
| (5) Stator Assembly | |
| (6) Generator Plate | |
| (7) Stator Housing | |

[A] GL6000, GL7000
[B] GL9000, GL11000

W1015204

2. AUTOMATIC VOLTAGE REGULATOR (A.V.R.)

■ NOTE

- It is hazardous to proceed to any high voltage test on the alternator without having previously disconnected all connections to voltage regulator.
Damages occurring to A.V.R. in such conditions will not be considered in a warranty claim.

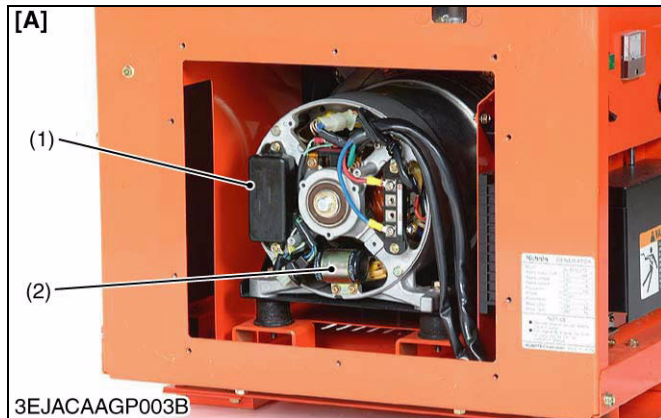

- (1) A.V.R.
(2) Capacitor

[A] GL6000, GL7000
[B] GL9000, GL11000

W1016141

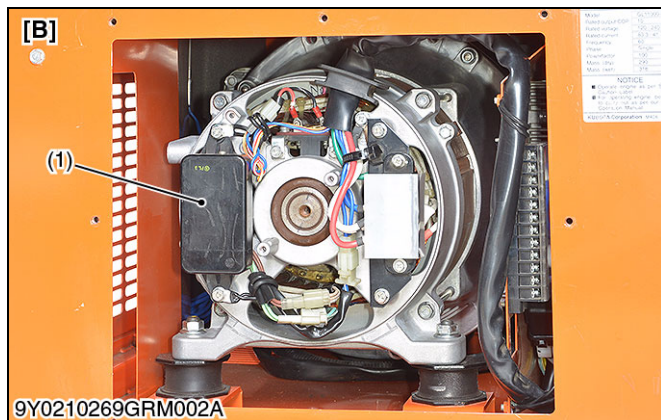

The block diagram of GL Series A.V.R.'s is shown below. The A.V.R. consists basically of the components detector (7) through transistor (4).

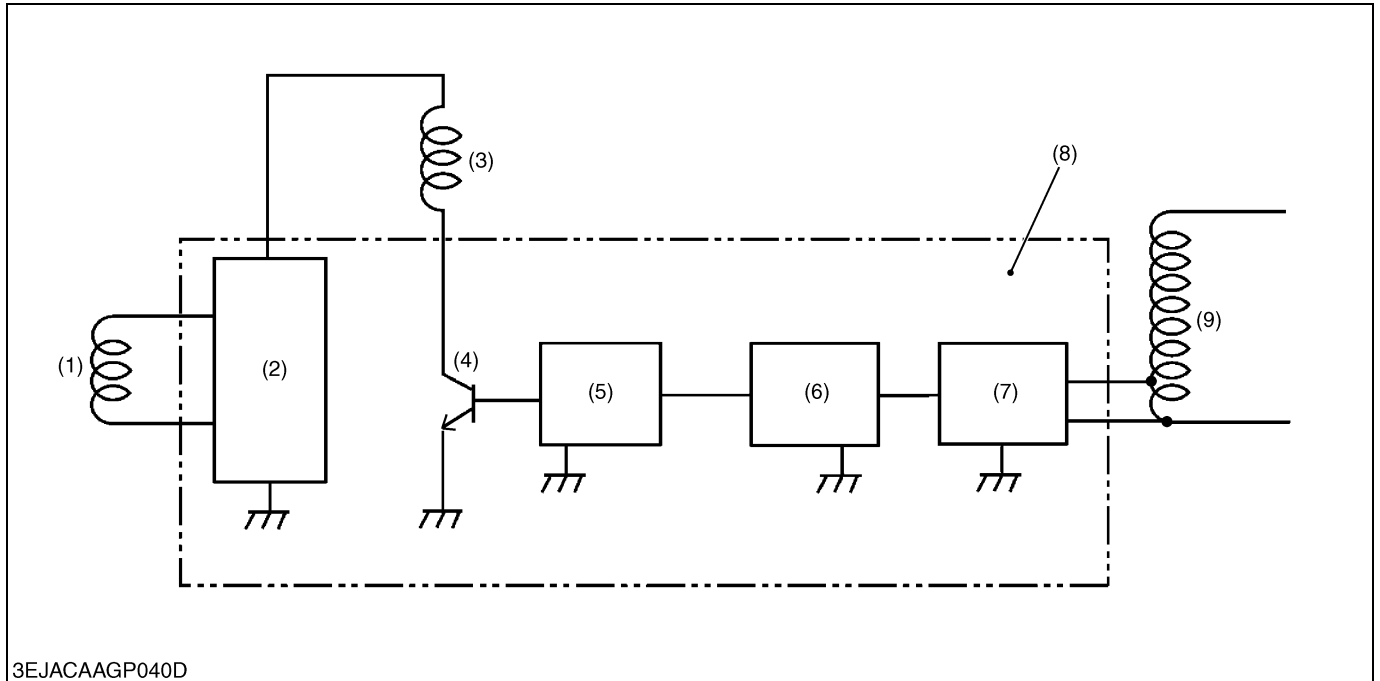

3EJACAAGP040D

- (1) Exciter Coil
- (2) Rectifier
- (3) Rotor Coil

- (4) Transistor
- (5) Drive Circuit

- (6) Controller
- (7) Detector

- (8) A.V.R.
- (9) Detection Coil

(1) Detector

The detector (7) monitors the generator's output voltage. The generator's detection coil (9) is connected to this component.

(2) Controller

The controller (6) is designed to compare the voltage picked up by the detector (7) with the preset reference voltage and to give a transistor **ON** and **OFF** signal to the next circuit (GL6000, GL7000 : drive circuit (5), GL9000, GL11000 : photocoupler). When the output voltage rises too high, it is made to drop; if it drops too low, it is made to rise.

(3) Drive circuit

The drive circuit (5) is basically composed of multiple transistors. The drive signal from the previous circuit controller (6) is weak. To intensify this signal, the final-stage transistor (4) that switches on and off the current to the rotor coil (3) is activated. For comparison, let's imagine a gearbox that gives a large torque from a small force. While the engine is stopped or in the low rpm range - that is, the generator voltage is not yet established, the drive circuit (5) behaves to keep the transistor (4) fully on.

(4) Transistor

The transistor (4) is designed to switch on and off the rotor coil (3) current and to adjust the generator's output voltage. On the GL Series A.V.R.s, the transistor is located projected from the mold with the heat sink.

(5) Rectifier

The rectifier (2) is intended to rectify the exciter output voltage and to feed power to the rotor coil (3). This component consists of diode stack and electrolyte capacitor.

3. EMERGENCY RELAY CIRCUIT

[1] GENERAL



This is an automatic engine stopping device. This device senses any abnormal situation on engine and related parts, such as oil pressure, water temperature, or fan belt broken, occurring during engine operation, and activates the stop solenoid to cut off fuel to the fuel injection pump and stop the engine. This relay has two independent timer functions, a start relay and a stop relay.

The start relay does not activate this relay for a specified time period after the engine has started.

■ IMPORTANT

- When this device stops the engine, it may be that some minor damages to the engine has occurred. To limit engine damage as much as possible, please do not make the faulty assumption that it is a perfectly safety device.

(1) Emergency Relay

[A] GL6000, GL7000

[B] GL9000, GL11000

W1017527

[2] INSTRUCTIONS

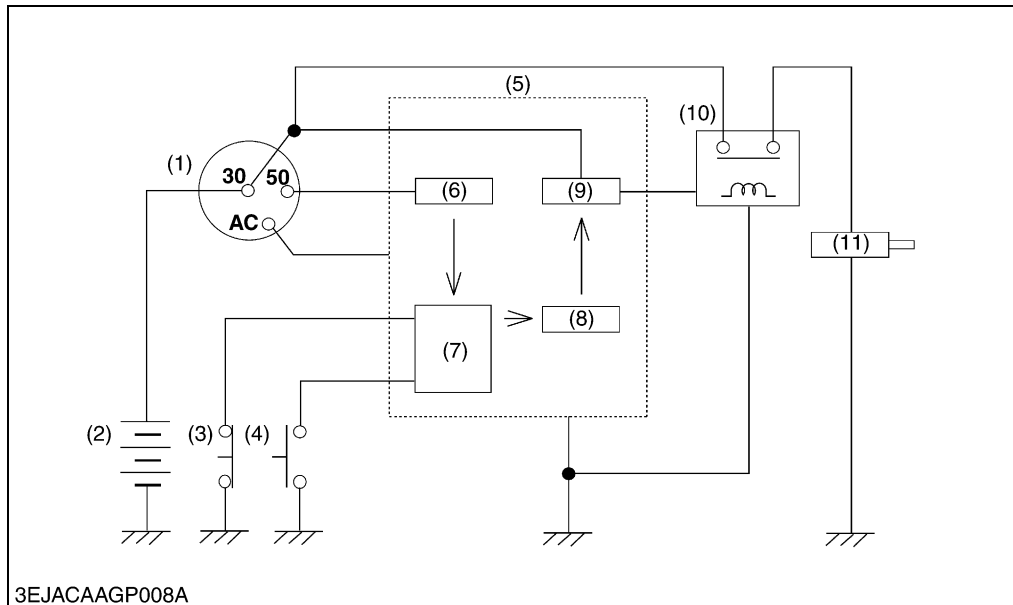

- (1) Key Switch
- (2) Battery (12 V)
- (3) Oil Switch
- (4) Water Temperature Switch
- (5) Emergency Relay
- (6) Delay Timer Circuit
- (7) Sensor Input Circuit
- (8) Drive Timer Circuit
- (9) Drive Circuit
- (10) External Relay
- (11) Stop Solenoid

W1025506

1. Circuit configuration

As shown in the block diagram above, emergency relay (5) (EG-1) comprises a delay timer for preventing the start of fault detection till the rise of oil pressure: a sensor input circuit for checking the oil pressure and the water temperature: a drive timer for energizing a stop solenoid (11) for a given time period in case of a fault input from a sensor: and a drive circuit for an external relay: Which energize the stop solenoid (11).

2. Details of the circuit (6)

- Delay timer circuit
Sets the delay time between the disengagement of the starter and the start of sensing. The timer operates on voltage from terminal 50 of the key switch (1).
- Sensor input circuit (7)
Monitors the oil switch (3) and the water temperature switch (4). When either of these switches is grounded for about 4 ms or more, the circuit will decide that sensor trouble has occurred, and provide output to the drive timer circuit (8).
- Drive timer circuit (8)
Sets the time for which to operate the stop solenoid (11). Upon receipt of an output from the sensor input circuit (7), the timer will start to operate.
- Drive circuit (9)
Drives the external relay (10) for a given delay time upon receipt of an output from the drive timer circuit (8). Consists of a power transistor, and a diode to remove surge volts from the relay.

3. Operating principle EG-1 controls so that:

- While an attempt was made to start the engine with the key switch (1) in the start position 50 terminal, the oil switch (3) and the water temperature switch (4) do not operate for fault detection.
- When the key switch (1) is returned to the **ON** and (**AC**), from the position mentioned in step above, a state will occur where fault detection is possible after an elapse of 6 to 12 seconds (at starter starting voltage and 20 °C (68 °F)).
- When the key switch (1) is turned to OFF after the start of the engine, or the water temperature switch (4) or the oil switch (3) detects a fault, the stop solenoid (11) will be energized for 7 to 13 seconds (at 12 V and 20 °C (68 °F)), and then disenergized.

4. EARTH

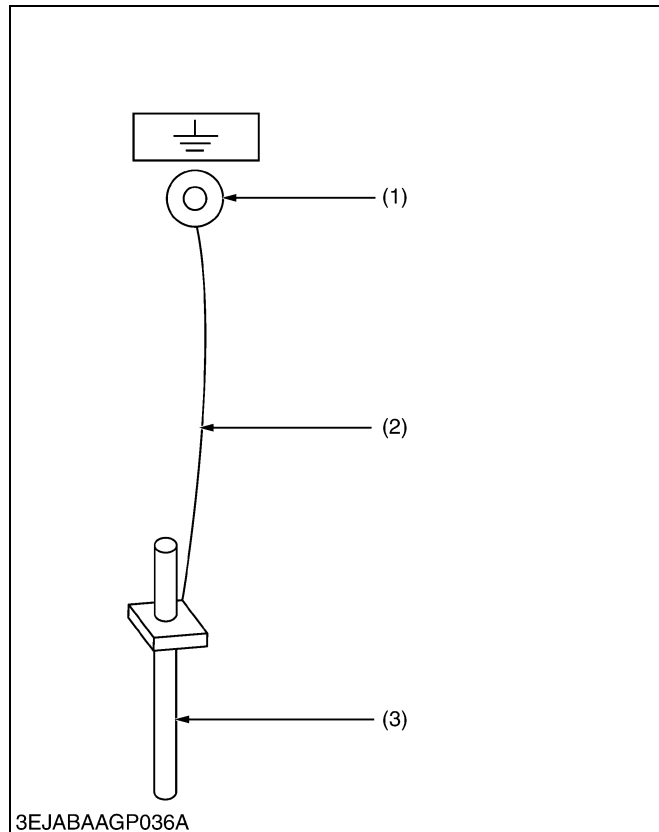

■ NOTE

- To avoid electric shock, connect a grounding cable to the ground terminal and ground it as shown in the figure. Use a 3 mm² or larger copper grounding cable whose grounding resistance is below 10 Ω.

Ground the generator as much as possible. The end user, equipment owner or operator must contact his local, state, county or municipal electric code department to determine the approved generator grounding method to be used in his application or location.

Recommendations in the NEC, NFPA and OSHA regulations must be followed to assure compliance and safe operation.

A grounding lug is provided on the KUBOTA generator frame for earth grounding depending on local, state, national or OSHA requirements.

One possible connection method for construction site use is as follows.

- | | |
|---|---|
| (1) Generator Ground Terminal | (3) Metal Ground Rod or Building Cold Water Pipe System Per N.E.C. Cord |
| (2) AWG Flexible Copper Ground Connection | |

W1018675

5. WIRING DIAGRAM

Color of Wiring

B Black	R Red	SB Sky Blue
Y Yellow	W White	LG Light Green
L Blue	BR Brown	P Pink
G Green	O Orange	GR Gray

W1019456

GL6000-STD (220V-50Hz)

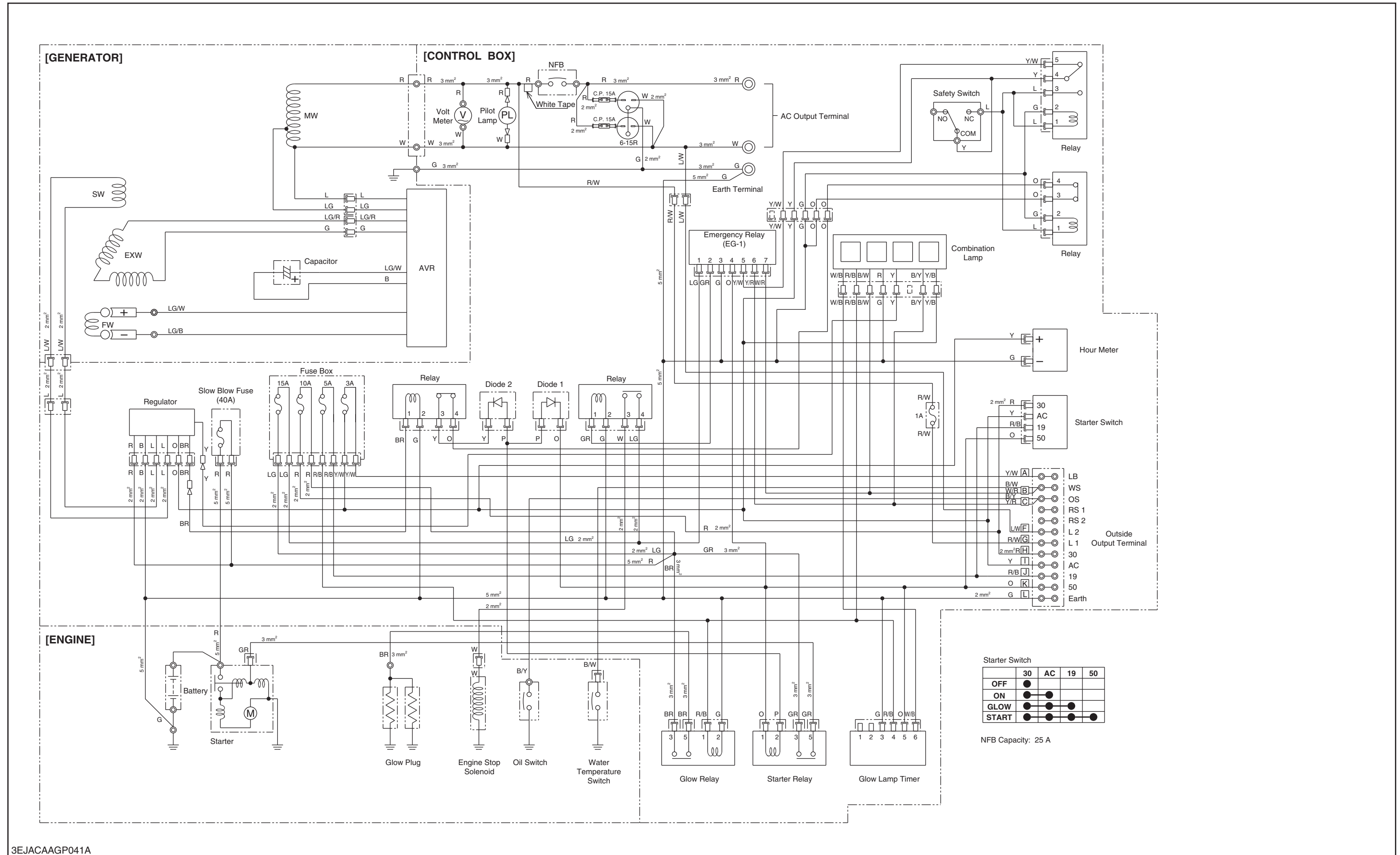

GL6000-AUS (240V-50Hz)

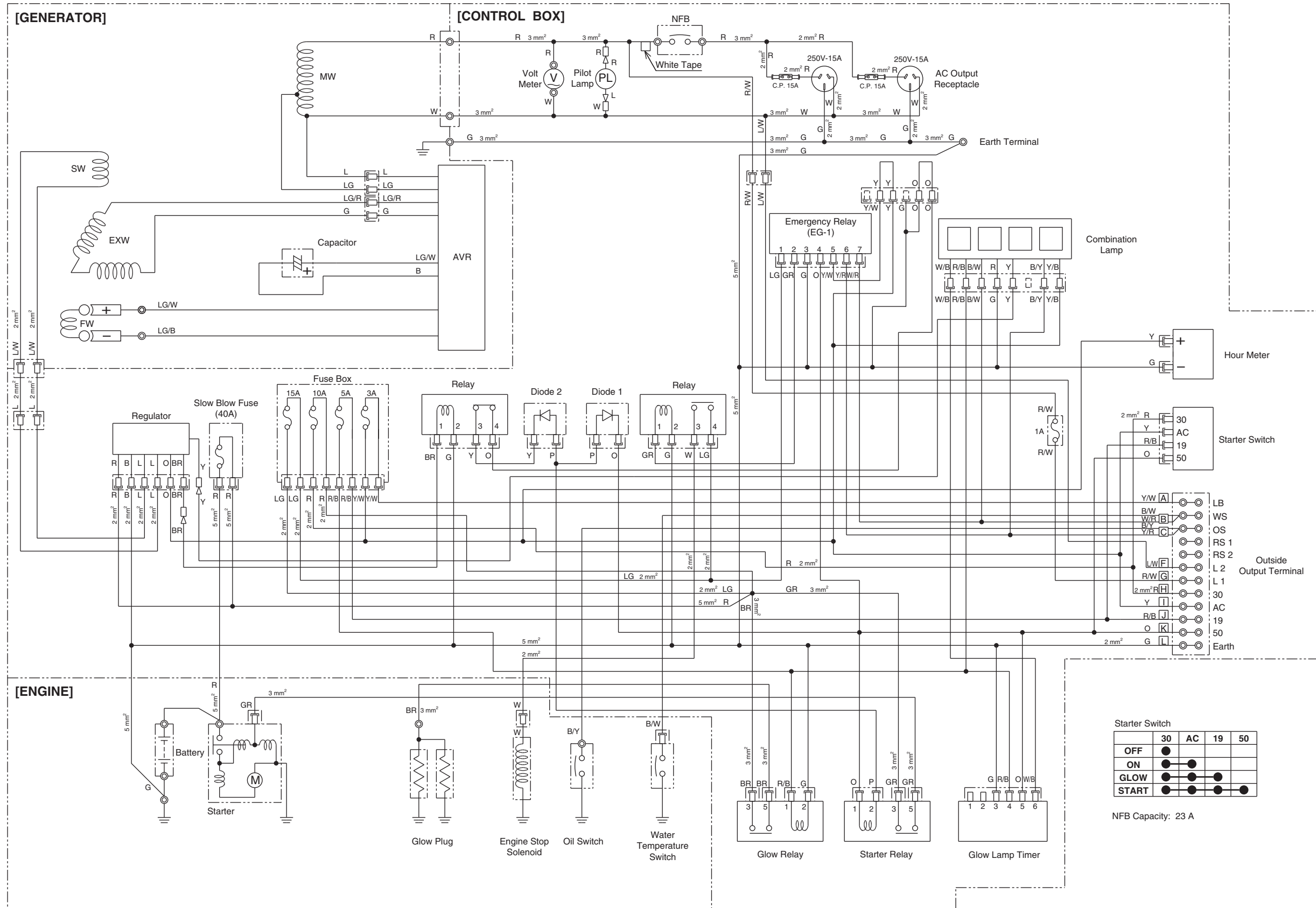

Starter Switch

	30	AC	19	50
OFF	●			
ON	●	●		
GLOW	●	●	●	
START	●	●	●	●

NFB Capacity: 23 A

GL7000-STD (110/220V-60Hz)

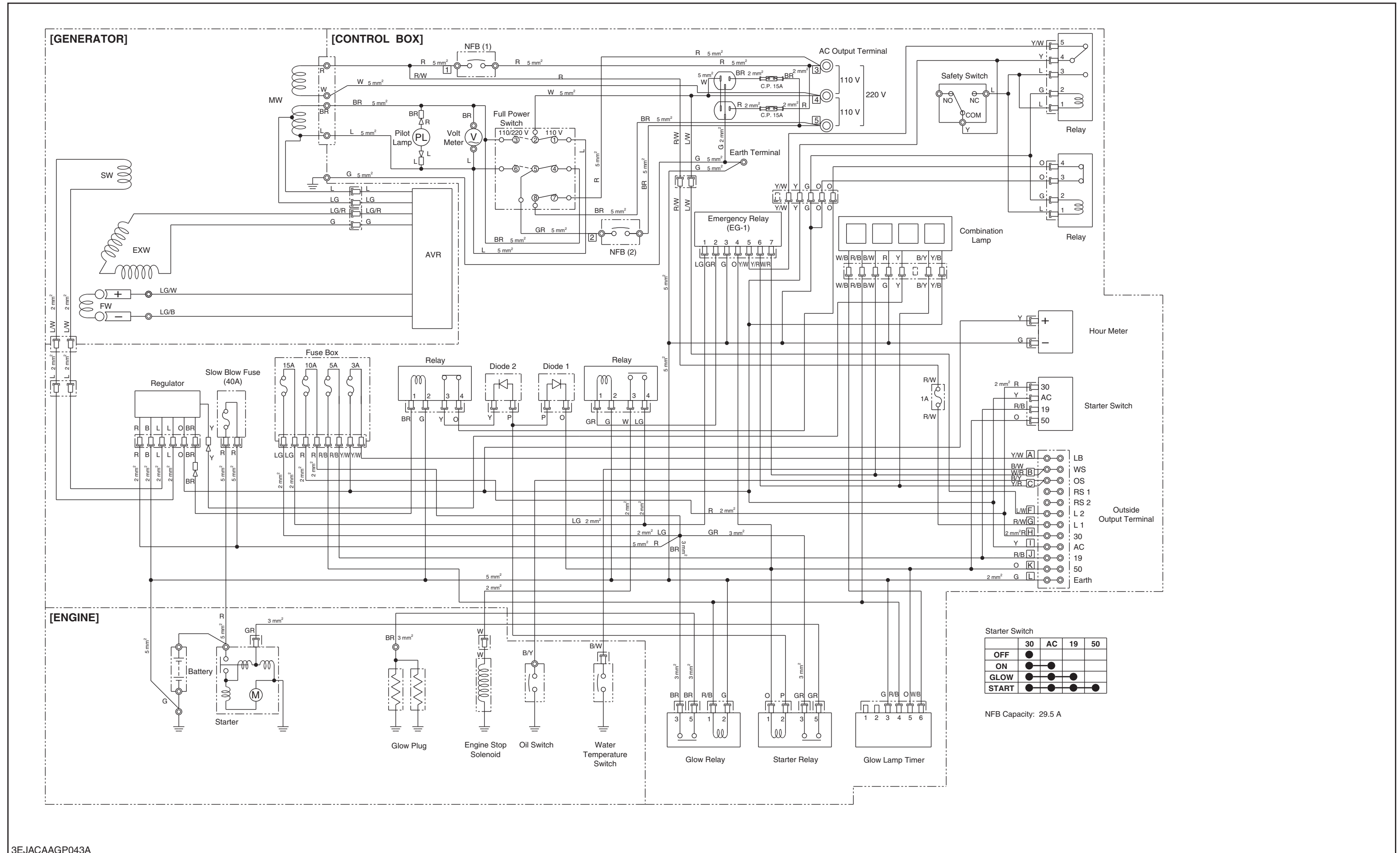

GL7000-USA (120/240V-60Hz)

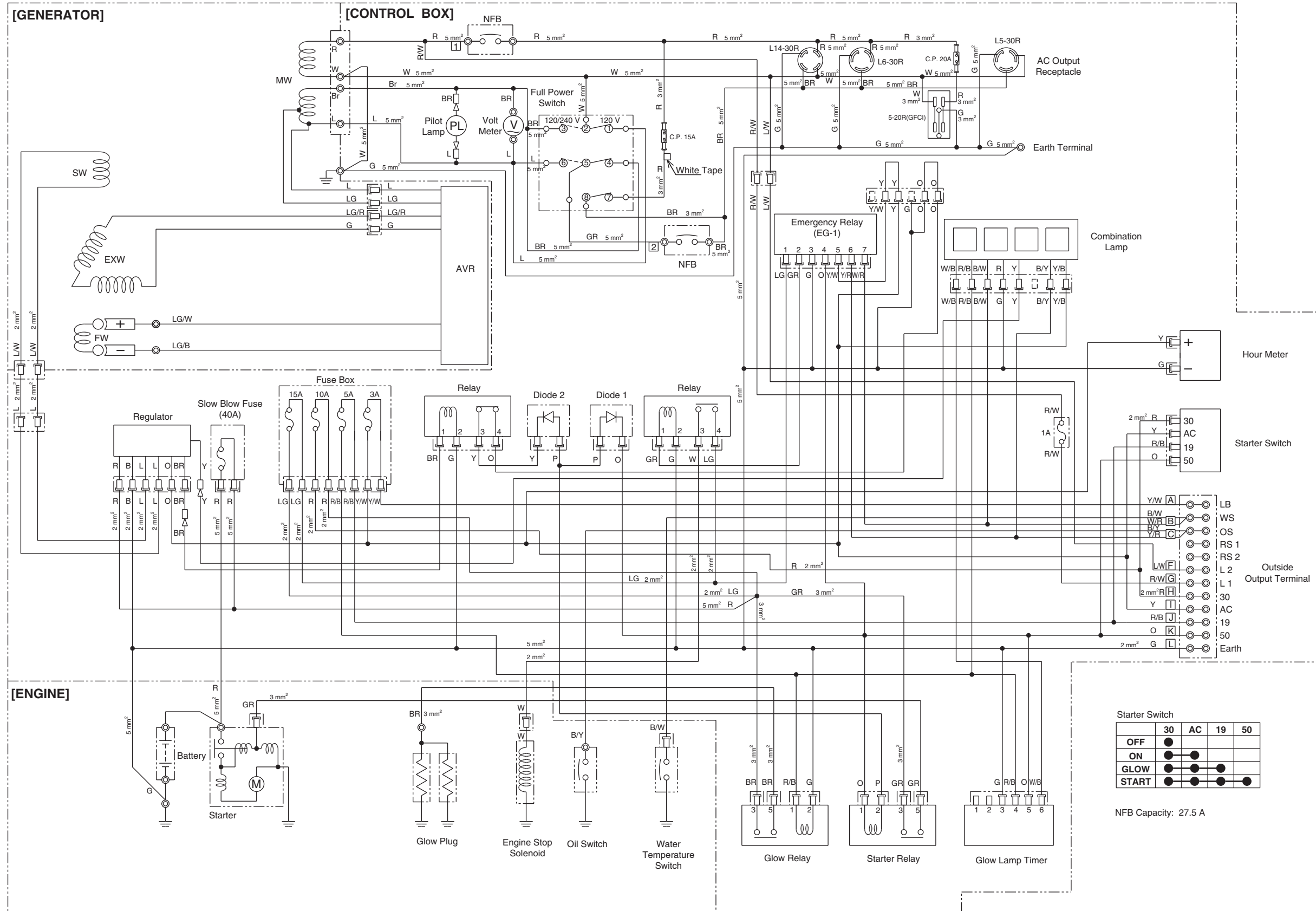

GL7000-USA-TM (120/240V-60Hz)

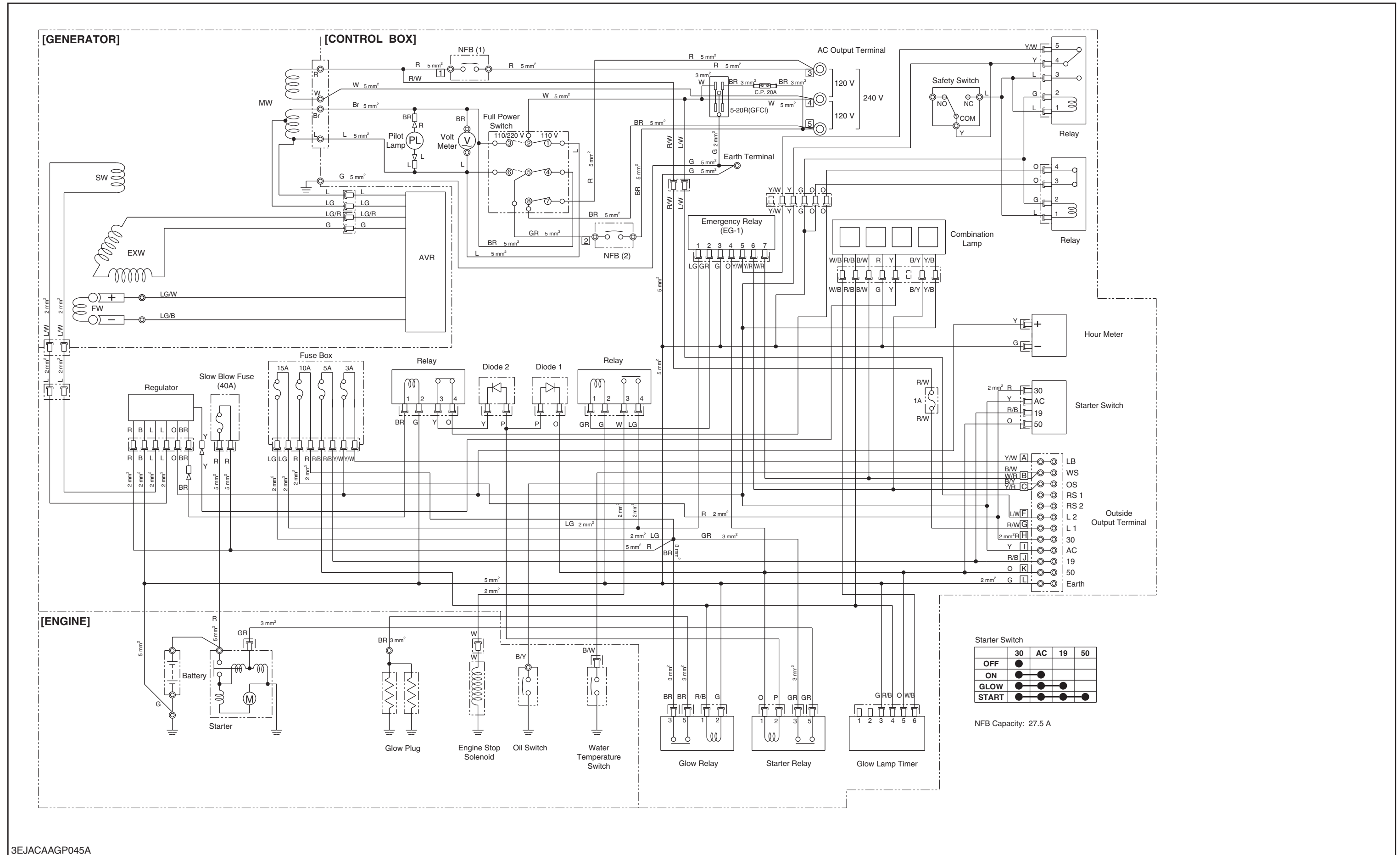

GL9000-STD (220V-50Hz)

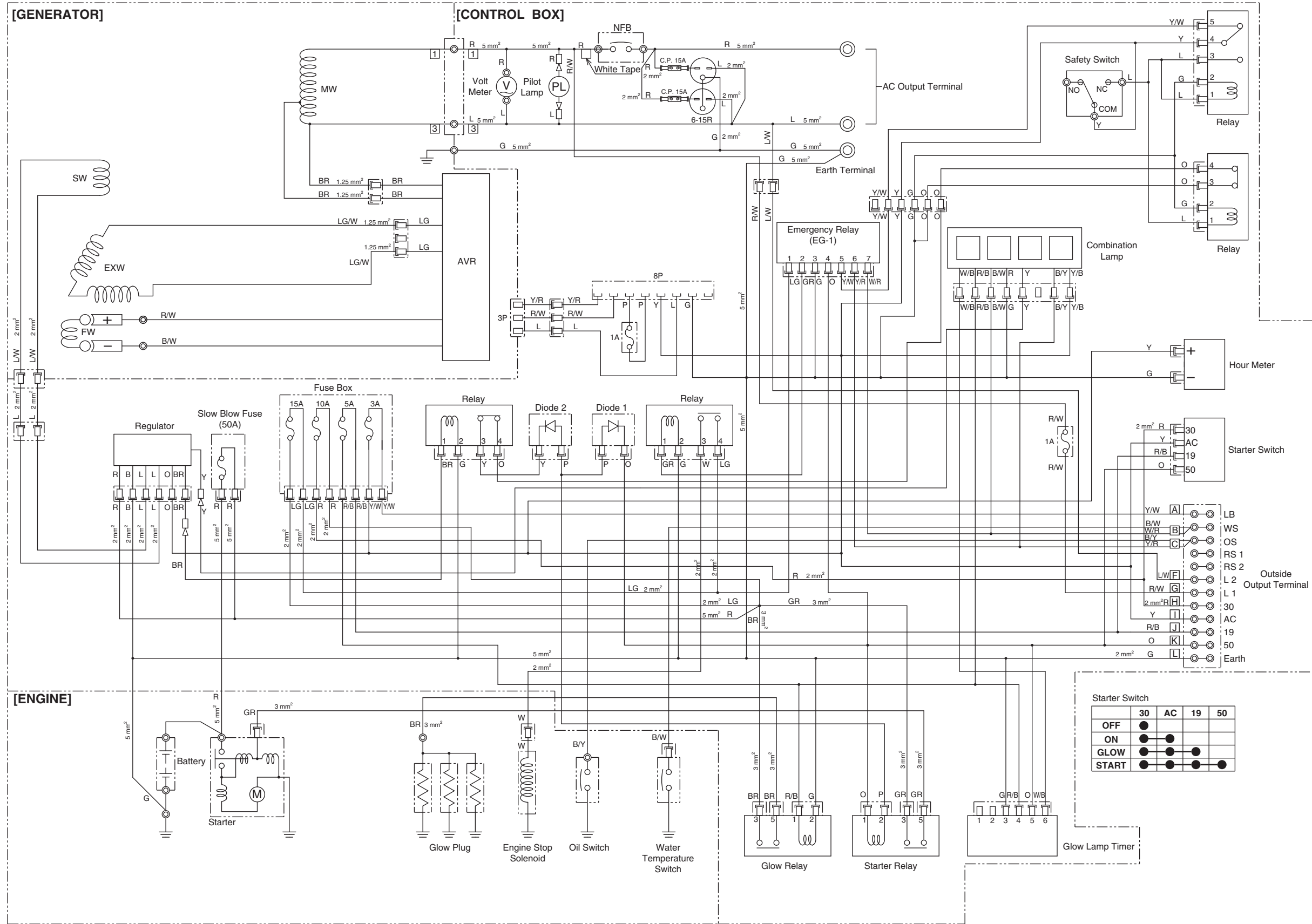

Starter Switch

	30	AC	19	50
OFF	●			
ON	●	●		
GLOW	●	●	●	
START	●	●	●	●

GL9000-AUS (240V-50Hz)

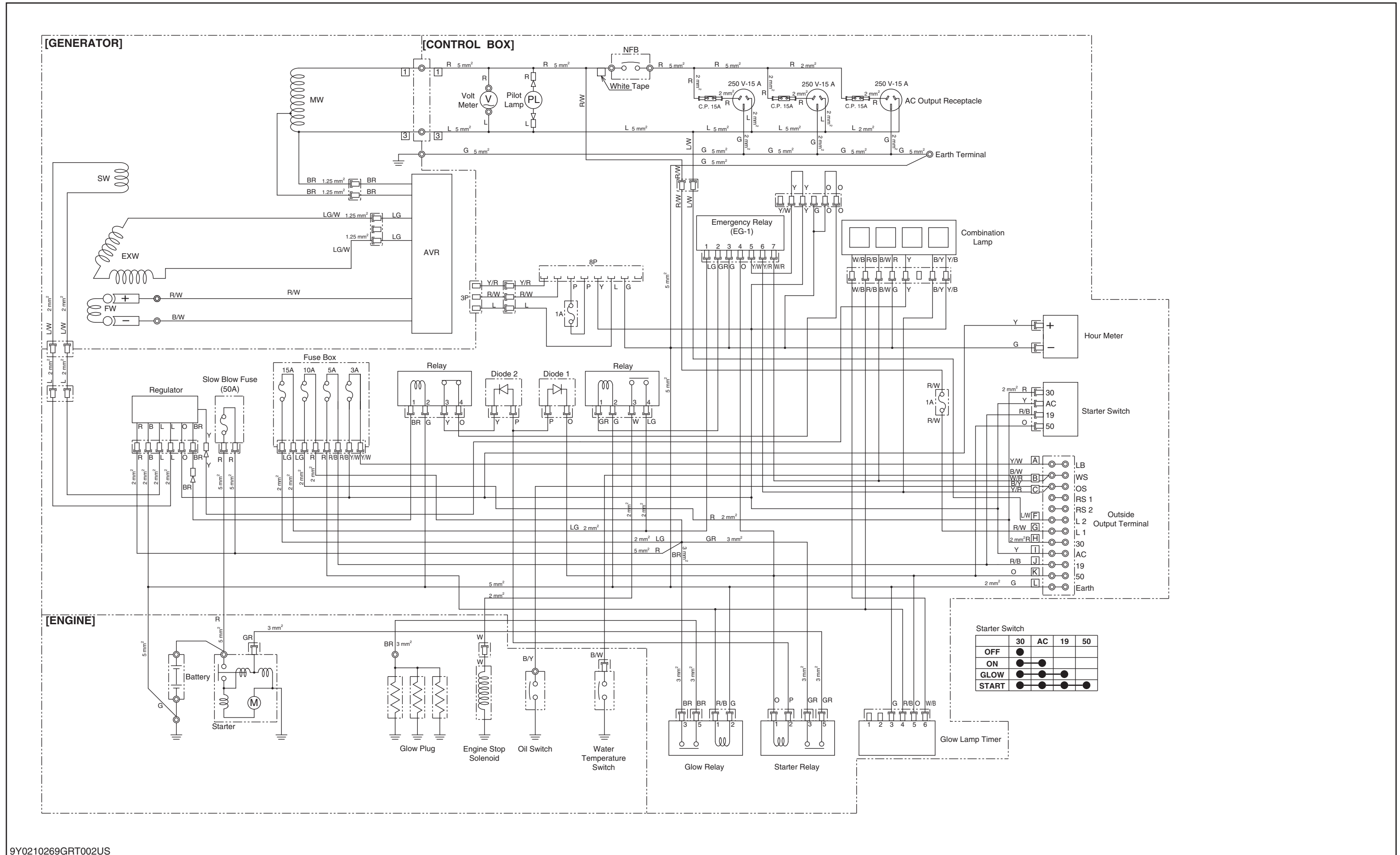

GL11000-STD (110/220V-60Hz)

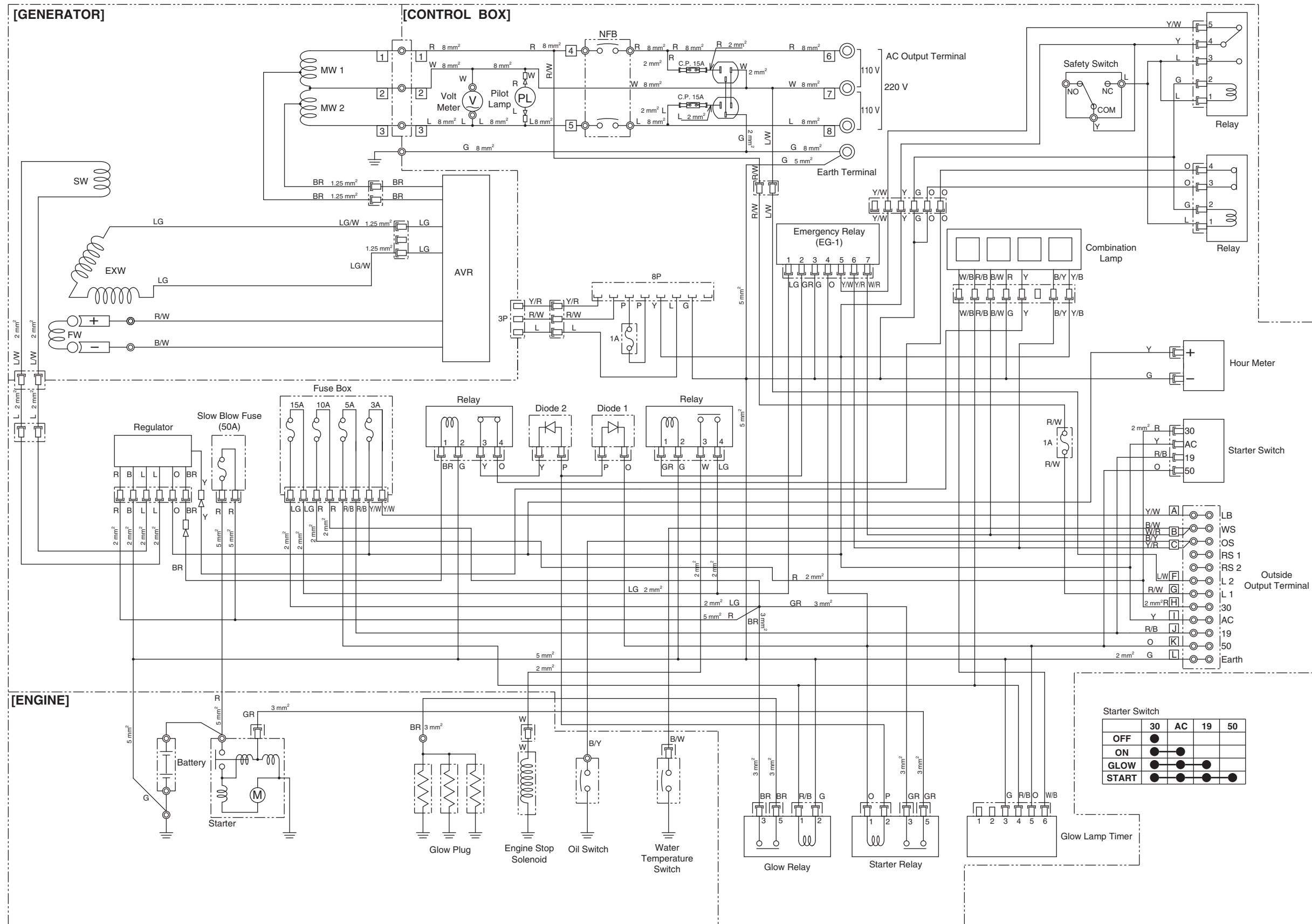

Starter Switch

	30	AC	19	50
OFF	●			
ON	●	●		
GLOW	●	●	●	
START	●	●	●	●

GL11000-USA (120/240V-60Hz)

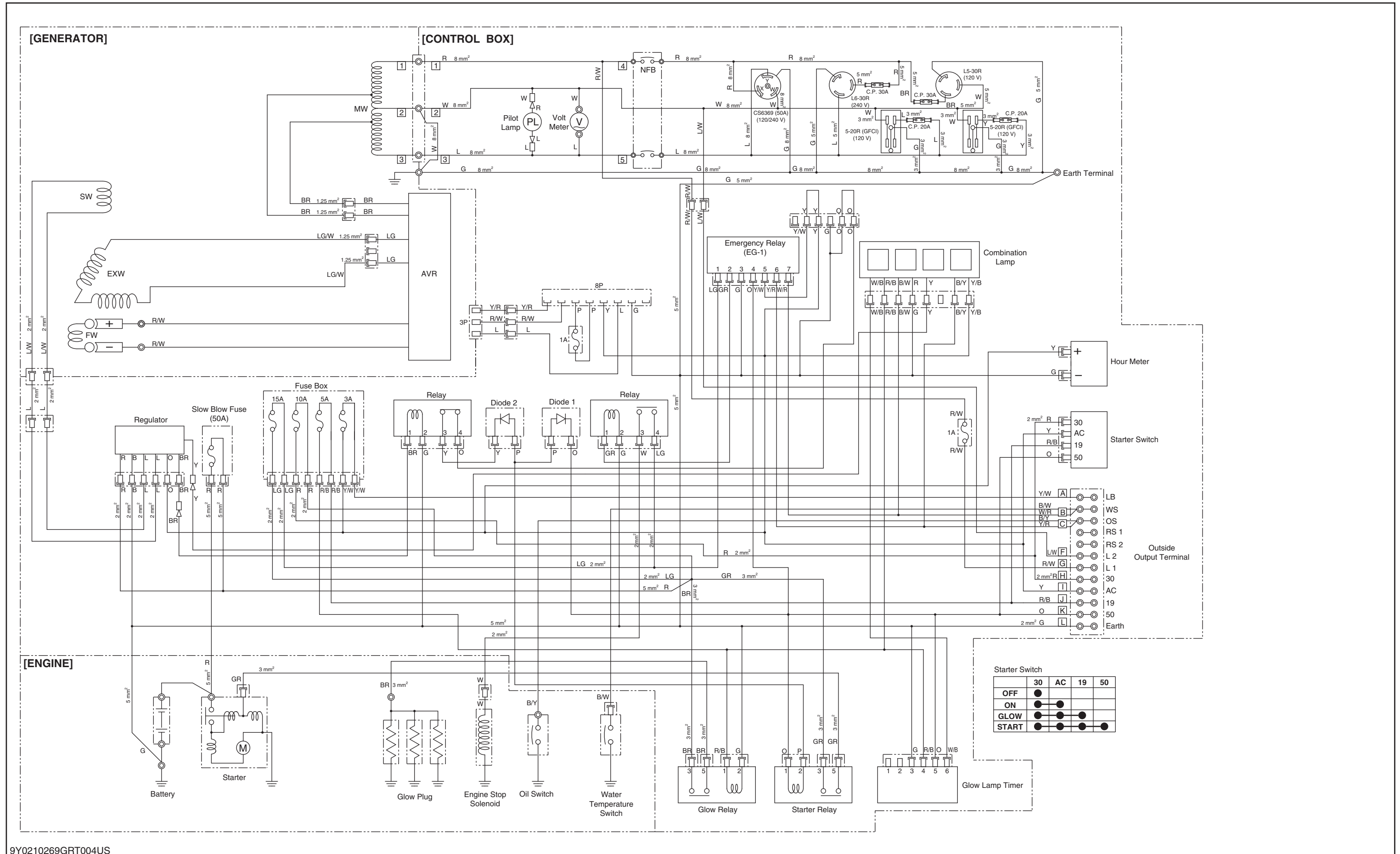

GL11000-USA-TM (120/240V-60Hz)

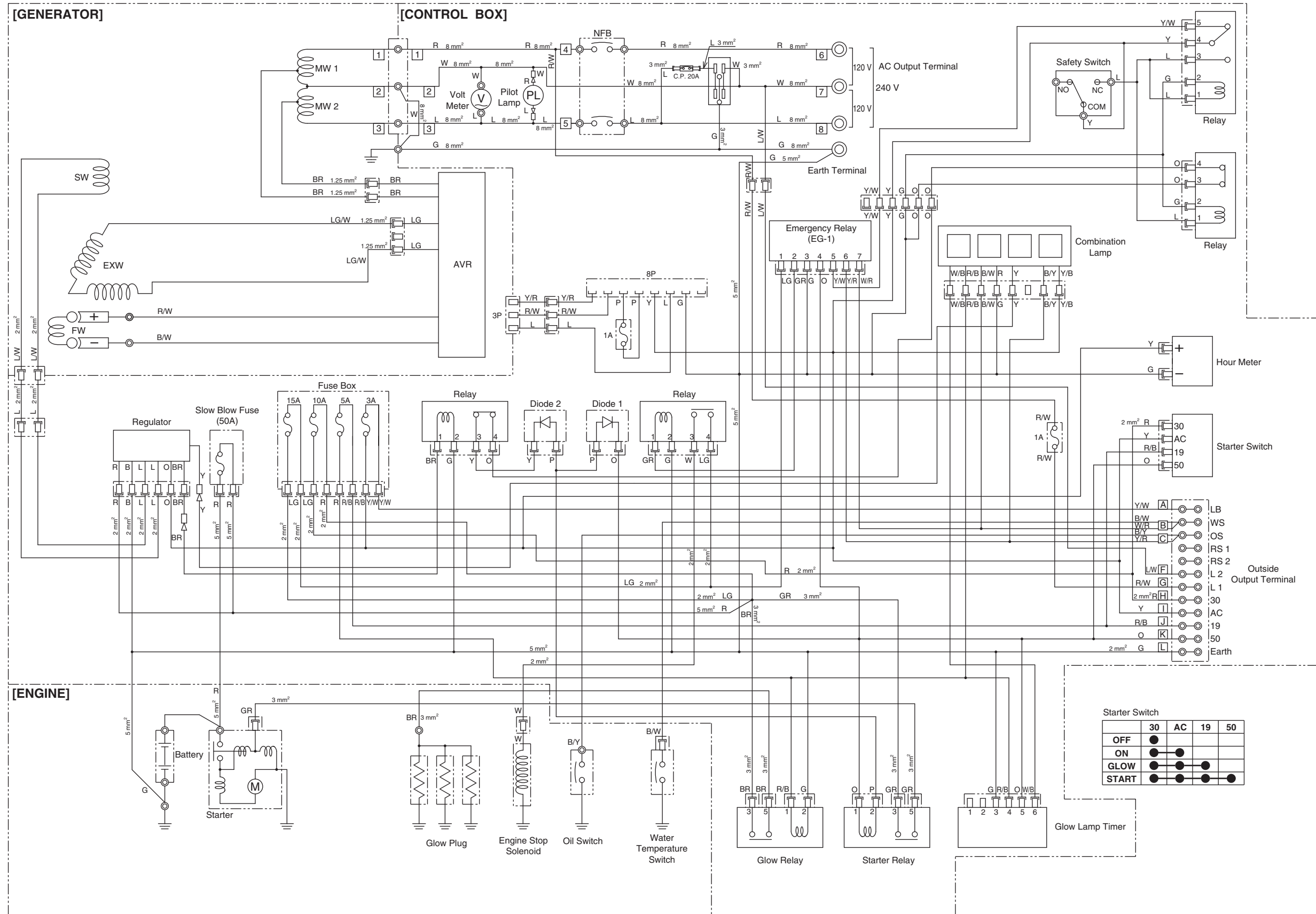

Starter Switch

OFF	●	●	●	●
ON	●	●	●	●
GLOW	●	●	●	●
START	●	●	●	●

SERVICING

CONTENTS

1. TROUBLESHOOTING	2-S1
[1] GENERATOR	2-S1
[2] ENGINE CIRCUIT	2-S4
2. SERVICING SPECIFICATIONS	2-S6
3. TIGHTENING TORQUES	2-S8
[1] TIGHTENING TORQUES FOR SPECIAL USE SCREWS, BOLTS AND NUT	2-S8
[2] TIGHTENING TORQUES FOR GENERAL USE SCREWS, BOLTS AND NUT	2-S9
4. CHECKING, DISASSEMBLING AND SERVICING.....	2-S10
[1] CHECKING AND ADJUSTING	2-S10
(1) Control Panel	2-S10
(2) Emergency Relay Activates	2-S16
[2] DISASSEMBLING AND ASSEMBLING.....	2-S17
(1) External Components	2-S17
[3] SERVICING	2-S20
(1) Terminal Voltage for Each Part During Normal Periods (No-load Periods).....	2-S20
(2) Stator Coil	2-S20
(3) Rotor Coil	2-S21
(4) Exciter Coil.....	2-S22

1. TROUBLESHOOTING

[1] GENERATOR

Evident Physical Defect (Overheating, Noise, Vibrations, ...)

Trouble	Possible Cause	Confirmation	Countermeasure
Excessive Overheating of Bearing (Temperature of Bearing Over 80 °C (176 °F)) (With or Without Abnormal Bearing Noise)	Bearing race badly locked	Check the condition of bearing and grease	Replace
	Bracket misalignment	Check the bracket alignment	Repair
Excessive Overheating of Generator Frame (Temperature 30 °C (86 °F) Above Ambient)	Air flow (inlet-outlet) partially clogged or hot air is being recycled either from generator or prime mover	Check the ventilation entrance Check the engine's fan and radiator	Check and Clean
	Generator overloaded	Check the voltage and current in the circuit	Replace
	Fan belt slips	Fan belt tension	Adjust
Excessive Vibration and Humming Noise Coming from The Generator	Short-circuit in the generator stator	Stop the gen-set and check the short-circuit, installation and others	Repair or replace
	Loosen bolt of generator mounting		
Generator Damaged by a Significant Impact Which is Followed by Humming and Vibration	Short-circuit in external circuit	Stop the gen-set immediately and check the related circuit and parts	Repair or replace
	Break or deterioration in the coupling		
	Break or twist in shaft extension		
	Shifting or short-circuit of the main field winding		
	Bursting or unlocking of the fan		
	Diode burnt, regulator, rectifier bridge damaged		
Smoke, Sparks of Flames Issuing From The Generator	Short-circuit in external circuit (including wiring between generator and control panel)	Stop the gen-set immediately and check the related circuit and parts	Repair or replace
	Object fallen into the machine		
	Short-circuit or flash in stator winding		

W1014322

Generator

Trouble	Checking Method	Measurement Operating Condition	Possible Cause	Countermeasure
Voltmeter Indicates Normal Voltage But no Output Voltage is Delivered.	Measure the voltage at the output terminal using a voltmeter. (250V at AC range)	Output voltage is 0 V.	Circuit breaker is OFF	Set the circuit breaker to ON. If it goes OFF again, check the cause (overload, short circuit, etc.). Set the circuit breaker to ON after removing the cause.
			Improper contact of output terminal or receptacle	Repair or replace
			Improper contact of the NFB wiring part (inside the control box)	Check wiring and repair
			Defective NFB	Replace
			Disconnected wiring harness (inside the control box)	Check wiring and repair
Voltmeter Does not Indicate Any Voltage and Also Output Voltage is not Delivered	Measure the voltage at the output terminal using a voltmeter. (250V at AC range)	Output voltage is 0 V.	Disconnected stator coil	Repair or replace
			Lack of residual magnetism	Replace rotor
		Only slight output voltage is delivered	Excessive wear of brush or improper contact of it	Replace brush and clean the contact surface of it
			Disconnected rotor coil	Repair or replace
			Defective A.V.R.	Replace
			Improper contact of the connector for A.V.R. & stator	Check and repair
			Excessive wear of brush or improper contact of it	Replace brush and clean the contact surface of it
Breaker Trips OFF	Measure the voltage at the output terminal using a voltmeter. (250V at AC range)	Output voltage is normal	Abnormality of loading circuit	Locate the cause (short-circuit, or overload, etc.) and remove

Trouble	Checking Method	Measurement Operating Condition	Possible Cause	Countermeasure
Output Voltage is too High	Measure the voltage at the output terminal using a voltmeter. (250V at AC range)	Excessive Output Voltage	Improper contact of the connector or disconnected wire (R) for detection coil	Repair or replace
			Disconnected detection coil in the stator	Repair or replace
			Defective A.V.R.	Replace A.V.R.
Rated Output is not Available	Check the variation of engine revolution or frequency when engine is loaded or not	Variation of engine speed is normal	Defective capacitor with A.V.R.	Replace A.V.R.
			Improper contact of brushes	Inspect and clean the brush contact surface, or repair or replace the brushes
		Variation of engine speed is excessive	Insufficient engine output	Repair engine
			Defective engine governor	Repair engine
	Measure the voltage at the output terminal using a voltmeter. (250V at AC range)	Output voltage is low	Lowered engine rotation	Adjustment of rotational speed
			Short-circuit of stator coil or sub coil.	Repair or replace
			Short-circuit of rotor coil	Repair or replace
			Defective A.V.R.	Replace A.V.R.
The Charge Lamp Lights After the Engine Starts	Measure the voltage at the stator terminal using a voltmeter. (50 V at AC range)	Output voltage is 0 V.	Improper contact of sub coil coupler	Inspect and repair
			Poor connection of the wiring for sub coil	Repair or replace
			Disconnected sub coil.	Repair or replace

W1084427

[2] ENGINE CIRCUIT

Trouble	Cause	Confirmation	Countermeasure
Engine Stops (The Engine Stops Approximately 10 Seconds After Starting.)	Insufficient engine oil	Check the oil level	Add the engine oil
	Defective oil switch	Check the oil switch	Replace
	Defective water temperature switch	Check the water temperature switch	Replace
	Defective wiring harness	Check the wiring harness	Repair or replace
Engine Stops	Terminal cover is opened	Check the terminal cover	Close
	Safety switch is failure	Check the safety switch	Replace
	Water temperature is too high	Check the coolant level	Replace
	Over heat	Check the monitor and the radiator clog	Repair or replace
	Engine breakdown	Check the engine exterior and oil level	Repair or add the engine oil
	Insufficient engine oil	Check the oil level	Add the engine oil
	Insufficient fuel	Check the fuel level	Add the fuel
Engine Does not Stop When Key Switch is "OFF" Position	Battery is disconnected	Check the battery	Replace
	Burnt out 15 A fuse	Check the fuse (15 A)	Replace
	Broken or disconnected wiring harness	Check the wiring harness and fuse (15 A)	Repair or replace
	Defective key switch	Check the key switch and the wiring	Replace
	Defective stop solenoid	Check the wiring harness and solenoid	Replace
	Defective emergency relay	Check the wiring harness, solenoid and emergency relay	Replace
The Charge Lamp Lights After The Engine Starts	Disconnected wiring harness or short-circuit	Check the wiring harness	Repair or replace
	Defective A.V.R.	Check the A.V.R.	Replace
	Disconnected sub coil	Check the sub coil	Replace
	Improper contact of sub coil wiring part	Check the sub coil and wire harness	Repair or replace

Trouble	Cause	Confirmation	Countermeasure
Charge Lamp Does not Light Even with The Key Switch Turned "ON" When The Engine is Stopped	Burnt out 10A fuse	Check the fuse (10 A) and the wiring	Repair or replace
	Charge lamp burned	Check the charge lamp and the wiring	

VV1088099

2. SERVICING SPECIFICATIONS

Item	Model	GL6000		GL7000		
		-STD	-AUS	-USA	-USA-TM	-STD
Frequency		50 Hz		60 Hz		
Voltage		220 V	240 V	120 / 240 V	←	110 / 220 V
Current		25 A	22.9 A	54.2 / 27.1 A	←	59.1 / 29.5 A
Main coil	R - W	0.55 Ω	0.62 Ω	0.28 Ω	←	0.25 Ω
	BR - L	–	–	0.28 Ω	←	0.25 Ω
Sub coil	G - LG/R	1.08 Ω	←	0.93 Ω	←	←
Sub coil (DC)	L/W - L/W	0.11 Ω	←	0.09 Ω	←	←
Detecting coil	LG - L	0.05 Ω	←	0.07 Ω	←	←
Rotor coil		59.5 Ω	←	←	←	←
Air gap		0.5 mm (0.020 in.)	←	←	←	←
Slip ring	Outside diameter	49.7 mm (1.96 in.)	←	←	←	←
	Correction limit	47.5 mm (1.87 in.)	←	←	←	←
	Standard run out	0.1 mm (0.003 in.)	←	←	←	←
	Limit run out	0.15 mm (0.0059 in.)	←	←	←	←
Brush length	Standard	15 mm (0.59 in.)	←	←	←	←
	Limit	4.5 mm (0.18 in.)	←	←	←	←
Bearing		6205 DDUNCX	←	←	←	←
Regulated voltage value		5 %	←	←	←	←
Circuit breaker capacity		25 A	23 A	27.5 A	←	29.5 A

W1028103

Item		Model	GL9000		GL11000		
			-STD	-AUS	-USA	-USA-TM	-STD
Frequency			50 Hz		60 Hz		
Voltage			220 V	240 V	120 / 240 V	←	110 / 220 V
Current			36.4 A	33.3 A	41.7 × 2 / 41.7 A	←	45.5 × 2 / 45.5 A
Main coil	1 - 3		0.28 Ω	0.34 Ω	0.23 Ω	←	0.19 Ω
	1 - 2		–	–	0.12 Ω	←	0.10 Ω
	2 - 3		–	–	0.12 Ω	←	0.10 Ω
Sub coil	LG - LG		1.96 Ω	←	1.68 Ω	←	1.73 Ω
Sub coil (DC)	L/W - L/W		0.08 Ω	←	0.07 Ω	←	←
Detecting coil	R - R		0.04 Ω	←	0.03 Ω	←	←
Rotor coil			55.5 Ω	←	←	←	←
Air gap			0.7 mm (0.03 in.)	←	←	←	←
Slip ring	Outside diameter		64 mm (2.51 in.)	←	←	←	←
	Correction limit		62.5 mm (2.46 in.)	←	←	←	←
	Standard run out		0.1 mm (0.003 in.)	←	←	←	←
	Limit run out		0.15 mm (0.0059 in.)	←	←	←	←
Brush length	Standard		15 mm (0.59 in.)	←	←	←	←
	Limit		7.5 mm (0.30 in.)	←	←	←	←
Bearing			6306 DDUNCX	←	←	←	←
Regulated voltage value			5 %	←	←	←	←
Circuit breaker capacity			36.5 A	33.5 A	42 A	←	45.5 A

W1019167

3. TIGHTENING TORQUES

Tightening torques of screws, bolts and nuts on the table below are especially specified.
(For general use screws, bolts and nuts : See page G-11.)

[1] TIGHTENING TORQUES FOR SPECIAL USE SCREWS, BOLTS AND NUT

■ NOTE

- In removing and applying the screws, bolts and nuts marked with " * ", pneumatic wrench or similar pneumatic tool, if employed, must be used with enough care not to get them seized.
- For " * " marked screws, bolts and nuts on the table, apply engine oil to their threads and seats before tightening.

[GL6000, GL7000]

Item	N·m	kgf·m	lbf·ft
Stator mounting screw	5.9 to 8.8	0.6 to 0.9	4.4 to 6.5
Rotor assembly mounting screw	34.3 to 44.1	3.5 to 4.5	25.3 to 32.5
PTO shaft mounting screw	48.1 to 55.9	4.9 to 5.7	35.5 to 41.2
Engine mounting nut	19.6 to 27.4	2.0 to 2.8	14.5 to 20.2
Generator mounting nut	19.6 to 27.4	2.0 to 2.8	14.5 to 20.2

[GL9000, GL11000]

Item	N·m	kgf·m	lbf·ft
Stator mounting screw	18 to 22	1.9 to 2.2	14 to 16
Rotor assembly mounting screw	19.6 to 27.4	2.0 to 2.8	14.5 to 20.2
Cooling fan mounting screw	19.6 to 27.4	2.0 to 2.8	14.5 to 20.2
Engine mounting nut	53.9 to 68.6	5.5 to 7.0	39.8 to 50.6
Generator mounting nut	53.9 to 68.6	5.5 to 7.0	39.8 to 50.6

W1046366

[2] TIGHTENING TORQUES FOR GENERAL USE SCREWS, BOLTS AND NUT

When the tightening torques are not specified, tighten the screws, bolts and nuts according to the table below.

Nominal Diameter	Grade Unit	Standard Screw and Bolt ④			Special Screw and Bolt ⑦		
		N·m	kgf·m	lbf·ft	N·m	kgf·m	lbf·ft
M4		1.0 to 2.9	0.1 to 0.3	0.7 to 2.1	–	–	–
M5		1.9 to 3.6	0.2 to 0.4	1.4 to 2.7	–	–	–
M6		7.9 to 9.3	0.80 to 0.95	5.8 to 6.9	9.8 to 11.3	1.00 to 1.15	7.23 to 8.32
M8		17.7 to 20.6	1.8 to 2.1	13.0 to 15.2	23.5 to 27.5	2.4 to 2.8	17.4 to 20.3
M10		39.2 to 45.1	4.0 to 4.6	28.9 to 33.3	48.1 to 55.9	4.9 to 5.7	35.4 to 41.2
M12		62.8 to 72.6	6.4 to 7.4	46.3 to 53.5	77.5 to 90.2	7.9 to 9.2	57.1 to 66.5

W10371750

Screw and bolt material grades are shown by numbers punched on the screw and bolt heads. Prior to tightening, be sure to check out the numbers as shown below.

Punched number	Screw and bolt material grade
None or 4	Standard screw and bolt SS41, S20C
7	Special screw and bolt S43C, S48C (Refined)

W1012705

4. CHECKING, DISASSEMBLING AND SERVICING

[1] CHECKING AND ADJUSTING

(1) Control Panel



Main Switch

1. Open the control panel (1).
2. Disconnect the **4P** connector and remove the main switch (2).
3. Perform the following checks.

- (1) Control Panel
- (2) Main Switch

- [A] Terminal Type
- [B] Receptacle Type

W1021025

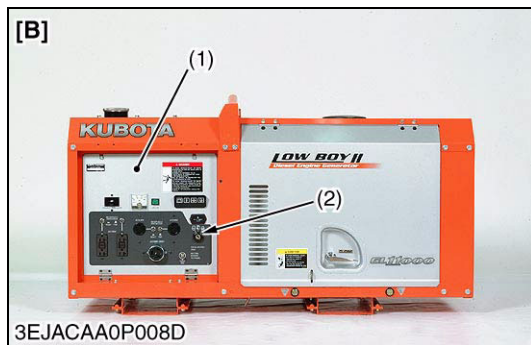

Connector Voltage

1. Measure the voltage with a voltmeter between the connector **30** terminal and chassis.
2. If the voltage differs from the battery voltage, the wiring harness is faulty.

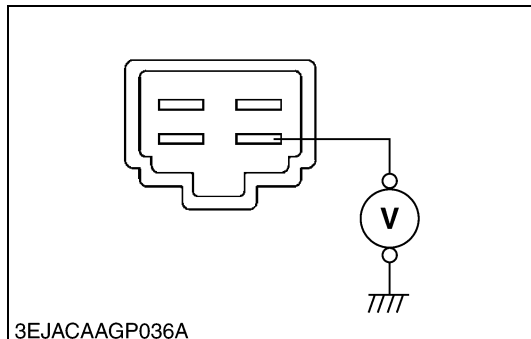

Voltage	Connector 30 terminal - chassis	Approx. battery voltage
---------	--	-------------------------

W1014533

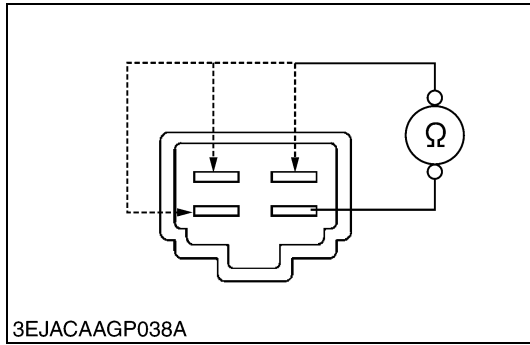
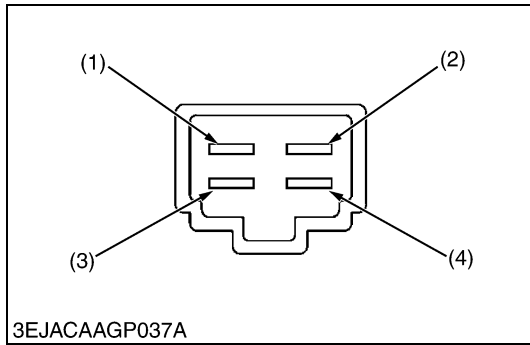

Main Switch Continuity

1) Main Switch Key at OFF Position

1. Set the main switch **OFF** position.
2. Measure the resistance with an ohmmeter across the **30** terminal and the **AC** terminal, **30** terminal and **50** terminal, **30** terminal and **19** terminal.
3. If infinity is not indicated, the contacts of the main switch are faulty.

Resistance	30 terminal – AC terminal	Infinity
	30 terminal – 50 terminal	
	30 terminal – 19 terminal	

2) Main Switch Key at ON Position

1. Set the main switch **ON** position.
2. Measure the resistance with an ohmmeter across the **30** terminal and the **AC** terminal.
3. If 0 ohm is not indicated, the **30** – **AC** contact of the main switch are faulty.

Resistance	30 terminal – AC terminal	0 Ω
------------	---	-----

3) Main Switch Key at GL Position

1. Set and hold the main switch key at the **GL** position.
2. Measure the resistance with an ohmmeter across the **30** terminal and the **19** terminal, and measure the resistance across the **30** terminal and the **AC** terminal.
3. If 0 ohm is not indicated, these contacts of the main switch are faulty.

Resistance	30 terminal – 19 terminal	0 Ω
	30 terminal – AC terminal	

4) Main Switch Key at START Position

1. Set and hold the main switch key at the **START** position.
2. Measure the resistance with an ohmmeter across the **30** terminal and the **19** terminal, across the **30** terminal and the **50** terminal, and across the **30** terminal and the **AC** terminal.
3. If 0 ohm is not indicated, these contacts of the main switch are faulty.

Resistance	30 terminal – 19 terminal	0 Ω
	30 terminal – 50 terminal	
	30 terminal – AC terminal	

- | | |
|------------------------|------------------------|
| (1) 19 Terminal | (3) 50 Terminal |
| (2) AC Terminal | (4) 30 Terminal |

W10136580

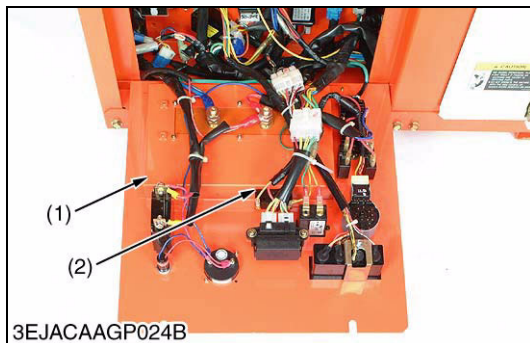

Safety Switch (for Terminal Type)

1. Open the control panel (1).
2. Disconnect the terminals and remove the safety switch (2).

- | | |
|-------------------|-------------------|
| (1) Control Panel | (2) Safety Switch |
|-------------------|-------------------|

W1020471



Safety Switch Continuity (for Terminal Type)

- When the safety switch (1) is turned **ON** and **OFF**, measure the resistance between the terminals of it each time.
- (a) when the measurement are the above table value. The safety switch (1) is normal.
(b) when the measurement are out of the above table value. The safety switch (1) is failure, then please exchange it.

Resistance	ON	Infinity
	OFF	0 Ω

(1) Safety Switch

A : ON

W10210220

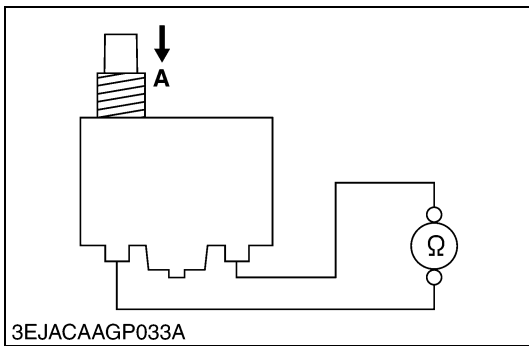

Lamp Timer (for Glow Plug)

- Remove the lamp timer from inside of the panel.
- Connect the battery (4), lamp timer (1) and bulb (2) as shown in the figure.
- The bulb (2) light up when contacting the lead wire 1 (3) with positive terminal of the battery (4) and goes off approximately 6 seconds late, the lamp relay is proper.

- (1) Lamp Timer for Glow Plug
- (2) Bulb

- (3) Lead Wire 1
- (4) Battery (12 V)

W1022263

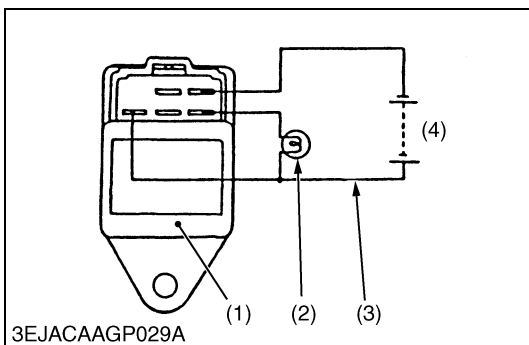
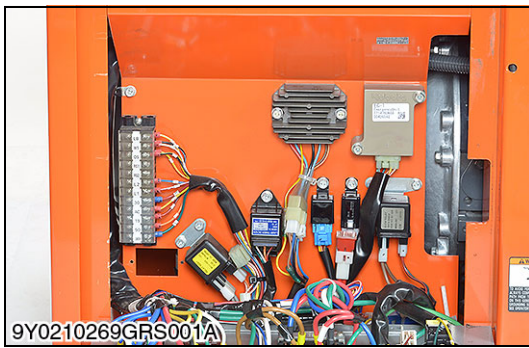

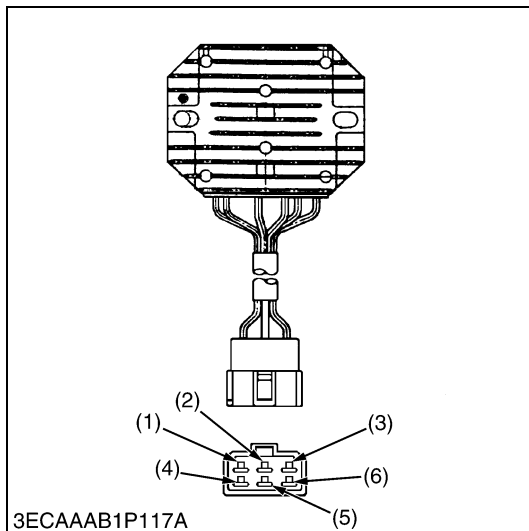

Regulator

1. Start the engine.
2. Measure the output voltage of the regulator with a circuit tester.

Output Voltage	Terminal 6 – Terminal 2	14 V to 15 V
----------------	-------------------------	--------------

3. When the measurement is not the above table value, measure the input voltage of the regulator with a circuit tester.

Input Voltage	Terminal 1 – Terminal 3	Approx. 14 V
---------------	-------------------------	--------------

4. When the measurement is the above table value, the regulator is failure. Replace it.

NOTE

- When the input voltage of the regulator is out of specification, check a dynamo.

- | | |
|----------------|----------------|
| (1) Terminal 1 | (4) Terminal 4 |
| (2) Terminal 2 | (5) Terminal 5 |
| (3) Terminal 3 | (6) Terminal 6 |

W1042693

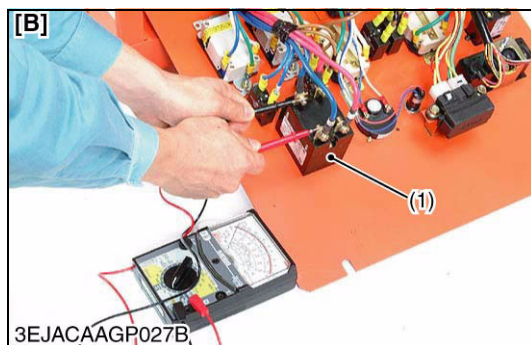
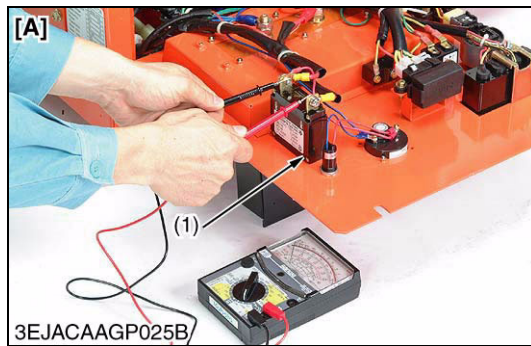
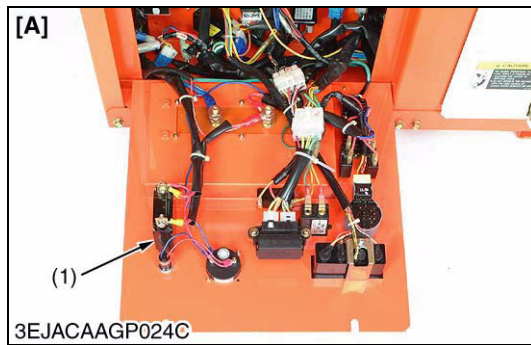

Circuit Breaker (NFB)

1. Test for continuity between the each upper and lower breaker terminals with an ohmmeter.
2. Make sure that there is continuity when the breaker switch in **ON**.
3. If there is no continuity, it indicates that the contacts are faulty. Replace the breaker.

■ NOTE

- **When there is a short-circuit in the wiring, the circuit breaker trips off. If this happens, eliminate the cause, then reset the circuit breaker. If the circuit breaker holds, test the load for faults.**

(1) Circuit Breaker

[A] GL6000, GL7000

[B] GL9000, GL11000

W1022525



Pilot Box

1. Continuity should exist between the terminals for each lamp.
2. If there is no continuity, change the lamp.

Charge	3 terminal – 4 terminal	Approx. 10 Ω
Water temperature	2 terminal – 8 terminal	
Oil pressure	7 terminal – 8 terminal	
Glow	1 terminal – 5 terminal	

- (1) Pilot Box
- (2) Charge
- (3) Water Temperature
- (4) Oil Temperature
- (5) Glow

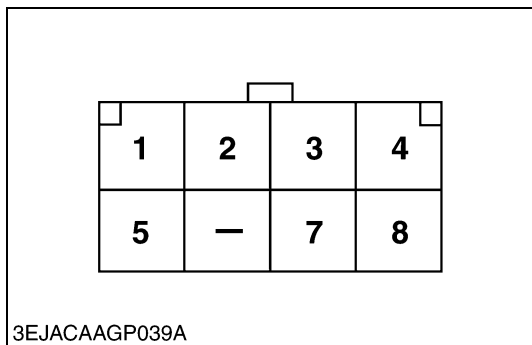
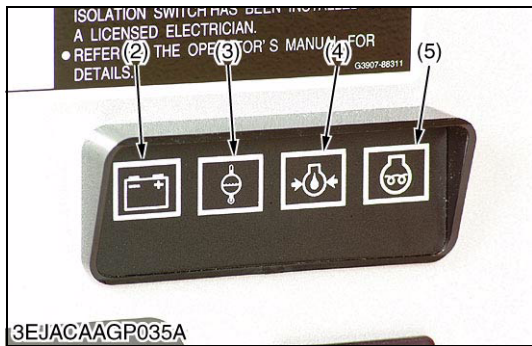

W1022841

(2) Emergency Relay Activates

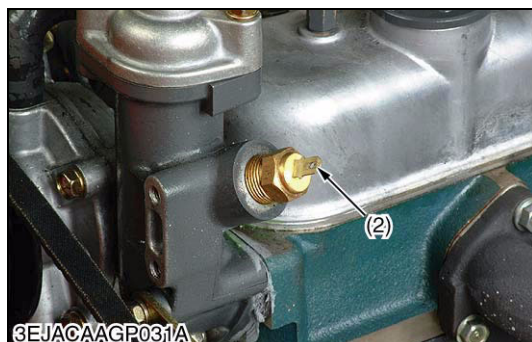

Emergency Relay Circuit

1. When the engine is running at rated rpm's connect the lead wires to the terminal of the oil switch (1) or the water temperature switch (2).
2. Also ground the other end of the lead wires to an unpainted portion of the engine frame.

(In normal operation)

- The stop solenoid activate and the engine stops automatically.
- After 7 to 13 seconds ia "tick" sound can be heard and the stop solenoid is released.

(1) Oil Switch

(2) Water Temperature Switch

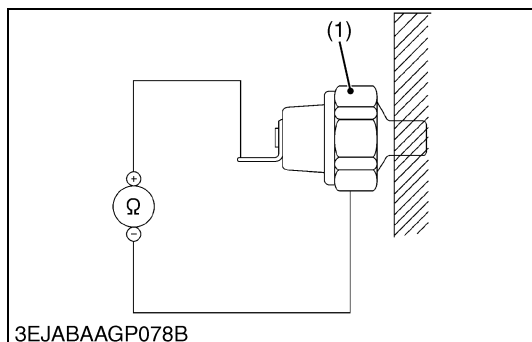

Oil Switch

1. The oil switch (1) has continuity when the engine is stopped and has no continuity while the engine is running.
2. Replace the oil switch (1) if it is defective.

Resistance (Switch terminal -Chassis)	In normal state	Infinity
	At pressure over approx. 98 kPa (1.0 kgf/cm ² , 28 psi)	0 Ω

(1) Oil Switch

W1020329

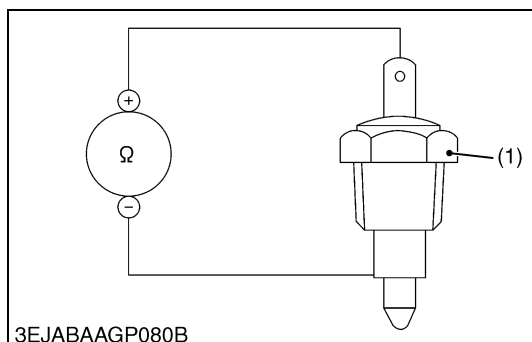

Water Temperature Switch

1. Insert the water temperature switch (1) in the engine oil, and continue the circuit when the oil temperature rises to 112 to 118 °C (234 to 244 °F).
2. Check that the resistance is 0 ohm in case water temperature switch is defective.

Water temperature switch	Factory spec.	Water temperature above than 112 to 118 °C (234 to 244 °F). Contact ON.
--------------------------	---------------	---

■ IMPORTANT

- **Be careful when handling the water temperature switch so that you do not drop it.**
- **When assembling the switch, apply sealing agent to the threads, and then screw it in firmly.**
- **Make a test run after installation, to check for any water leaks.**

(1) Water Temperature Switch

W1020452

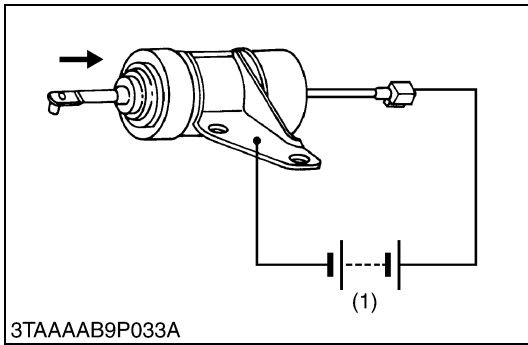

Engine Stop Solenoid Test

1. Disconnect the **1P** connector from the engine stop solenoid.
2. Remove the engine stop solenoid from the engine.
3. Connect the jumper leads from the battery positive terminal to the **1P** connector, and from the battery negative terminal to the engine stop solenoid body.
4. If the solenoid plunger is not attracted, the engine stop solenoid is faulty.

(1) Battery (12 V)

W1063720

[2] DISASSEMBLING AND ASSEMBLING

(1) External Components

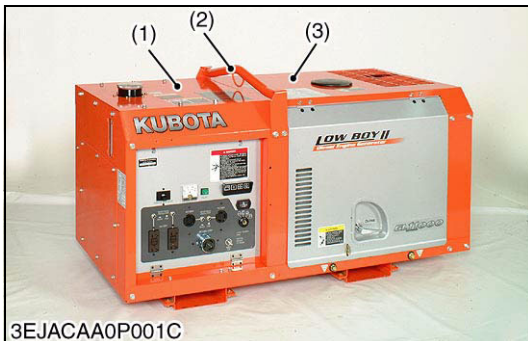

Panel, Cover, Control Panel

1. Close the fuel valve and remove the fuel hose.
2. Remove the hanger (2), the engine roof (3) and the generator roof (1) with fuel tank.
3. Remove the front frame (6) and rear cover (4) and side cover (5).
4. Disconnect the connector between the generator (9) and control panel (10).
5. Disconnect the ground cables (7).
6. Remove the control panel (10) and cooling air port cover (8).

- (1) Generator Roof
- (2) Hanger
- (3) Engine Roof
- (4) Rear Frame
- (5) Side Cover

- (6) Front Frame
- (7) Ground Cables
- (8) Cooling Air Port Cover
- (9) Generator
- (10) Control Panel

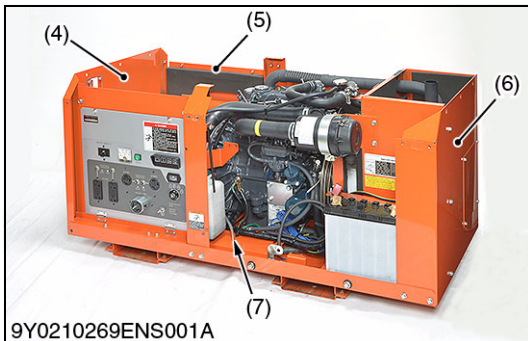

W1027763

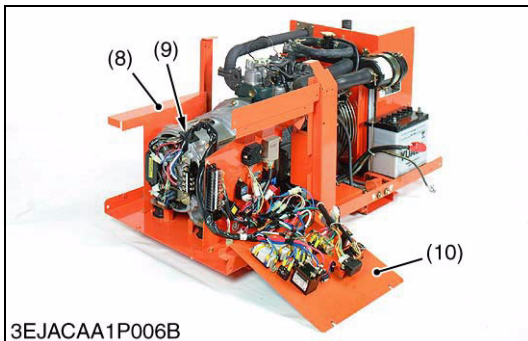

(2) Generator

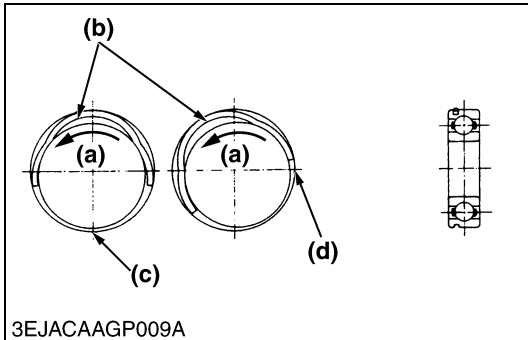
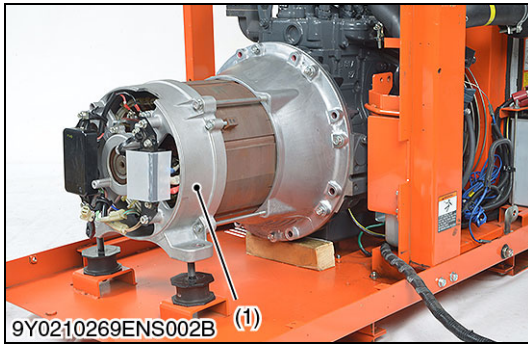

Rear Bracket

1. Remove the rear bracket mounting nuts.
2. Disconnect the wire harness and the carbon brushes, etc.
3. Lift up the generator.
4. Remove the rear bracket (1).

(When reassembling)

- Clean dirt from the bearing housing.
- When installing the bearing, make sure the relative positioning between the snap ring and outer ring is correct. Follow the point below.
- Be certain that the center of the bulge of the snap ring is in the bottom of the eccentric groove of the outer ring (there is a mark on the outer ring's outside surface). Now put the NCX bearing in its housing. Be careful to position the bearing correctly. Misalignment may make it difficult to install the bearing or what's worse, damage it.

■ IMPORTANT

- **Be careful not to confuse the direction of the snap ring of the bearing.**

[GL6000, GL7000]

Tightening torque	Stator mounting screw	5.9 to 8.8 N·m 0.6 to 0.9 kgf·m 4.4 to 6.5 lbf·ft
-------------------	-----------------------	---

[GL9000, GL11000]

Tightening torque	Stator mounting screw	18 to 22 N·m 1.9 to 2.2 kgf·m 14 to 16 lbf·ft
-------------------	-----------------------	---

(1) Rear Bracket

(a) Direction of rotation

(b) Snap ring

(c) Bottom of the eccentric groove

(d) Wedge place

W1030949

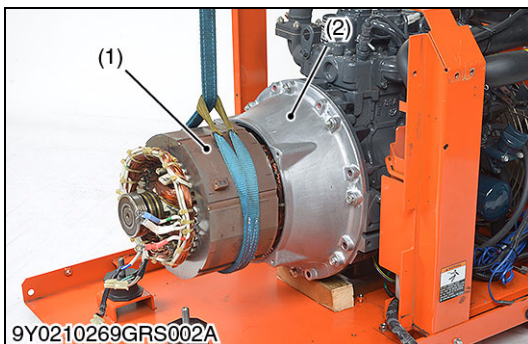

Stator Assembly and Stator Housing

1. Hoist up the stator assembly (1).
2. Remove the stator assembly (1), take care not to damage the winding and the rotor.
3. Remove the stator housing (2).

(When reassembling)

- Do the set-up in the original position (direction).

(1) Stator Assembly

(2) Stator Housing

W1031068

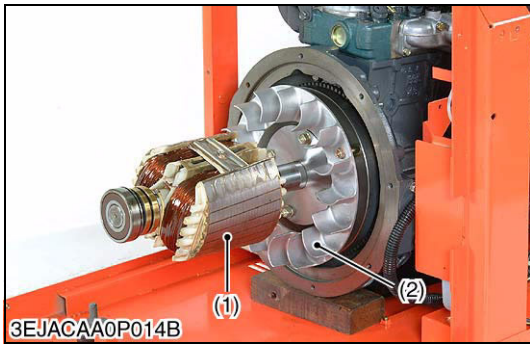

Rotor Assembly

1. Remove the cooling fan (2).
2. To avoid damage to the rotor assembly (1), suspend the rotor assembly (1) with a sling belt enough to keep it from lifting, and leave it suspended.
3. Remove the rotor assembly mounting screws.
4. Remove the rotor assembly (1), take care not to damage the winding.

(When reassembling)

- Clean any oil and dirt from the mounting surfaces of the rotor and flywheel. If this is not done correctly, it will result in damage of rotor and stator caused by loose fittings.
- Handle carefully to avoid damaging the winding.

Tightening torque	Cooling fan mounting screw		19.6 to 27.4 N·m 2.0 to 2.8 kgf·m 14.5 to 20.3 lbf·ft
	Rotor assembly mounting screw	GL6000, GL7000	34.3 to 44.1 N·m 3.5 to 4.5 kgf·m 25.3 to 32.5 lbf·ft
		GL9000, GL11000	19.6 to 27.4 N·m 2.0 to 2.8 kgf·m 14.5 to 20.3 lbf·ft

(1) Rotor Assembly

(2) Cooling Fan

W1066726

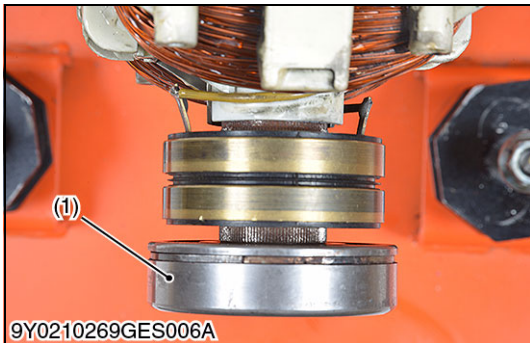

Replacing Ball Bearing

1. Hook the puller until it clicks onto the outer bearing ring and then pull off the bearing.

(When reassembling)

- Keep new bearing sealed until use.
- Clean dirt from the bearing housing.
- When tapping in the bearing, press it by tapping on the inner race gently with special tool

(1) Ball Bearing

W1067349

[3] SERVICING

(1) Terminal Voltage for Each Part During Normal Periods (No-load Periods)



Output Terminal

1. With the NFB in the **ON** position, measure the voltage in each phase and each line.
2. If the factory specification is not indicated, inspect the output circuit or the wiring harness.
(Refer to "**5. WIRING DIAGRAM**" (2-M8).)

Output voltage	Factory spec.	Rated voltage 7 or 8 %
----------------	---------------	------------------------

[A] Terminal Type

[B] Receptacle Type

W1068933



(2) Stator Coil



Main Coil Winding

1. Test for continuity between coil leads with a milliohm meter.
Many kind of wiring have been arranged in the stator depending on the voltage variation.
2. If the resistance is not as specified, replace the stator or contact service station.
(Refer to "**5. WIRING DIAGRAM**" (2-M8).)

Resistance	Factory spec.	Refer to " 2. SERVICING SPECIFICATION " (2-S6).
------------	---------------	--

* Measurement is not possible with a regular tester.

[A] G6000, GL7000

[B] GL9000, GL11000

W1026118

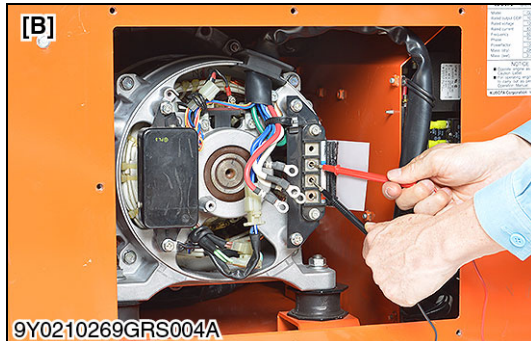



Detecting Coil

1. Measure the coil resistance between each auxiliary winding.
2. If the factory specification is not indicated, replace the stator or contact service station.
(Refer to "5. WIRING DIAGRAM" (2-M8).)

Resistance	Factory spec.	Refer to "2. SERVICING SPECIFICATION" (2-S6).
------------	---------------	---

[A] G6000, GL7000

[B] GL9000, GL11000

W1068968

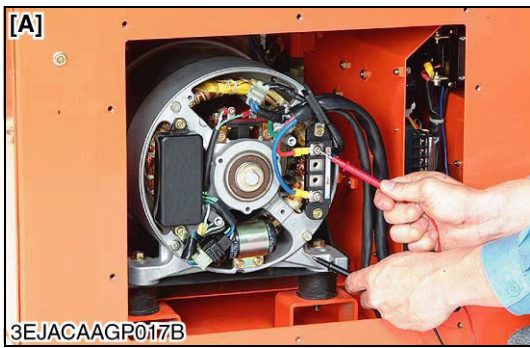
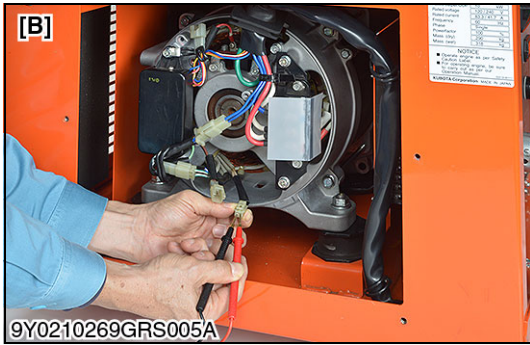

Grounding of Stator Coil

1. Measure the insulation resistance between each stator winding and lamination with a megohm meter.
2. Reading should be more than 1 MΩ at 500 V.
3. If continuous, replace the stator or contact service station.

[A] G6000, GL7000

[B] GL9000, GL11000

W1069388

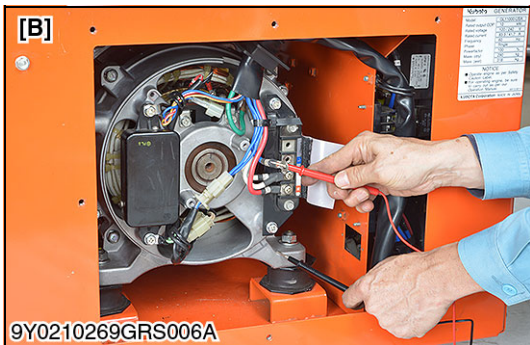

(3) Rotor Coil

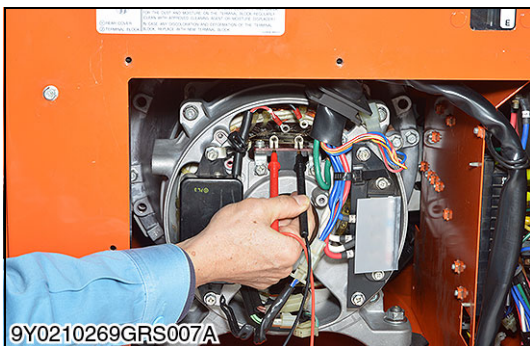

Main Field Winding (Rotor Coil)

1. Measure the coil resistance between each end of field coil.
2. If the resistance is not as specified, replace the rotor assembly or contact service station.
(Refer to "5. WIRING DIAGRAM" (2-M8).)

Resistance	Factory spec.	Refer to "2. SERVICING SPECIFICATION" (2-S6).
------------	---------------	---

W1026895

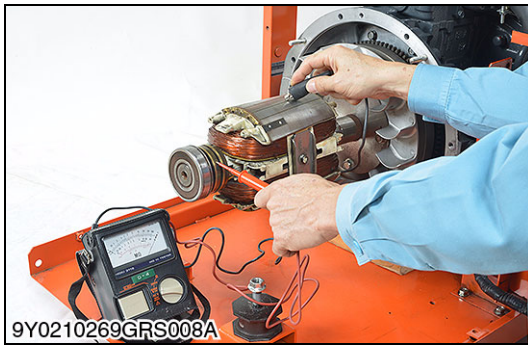

Grounding of Rotor Coil

1. Connect leads of a megohm meter between each lead and exciter rotor laminations.
2. Reading should be more than 1 MΩ at 500 V.
3. If continuous, replace the rotor assembly or contact service station.

W1070603

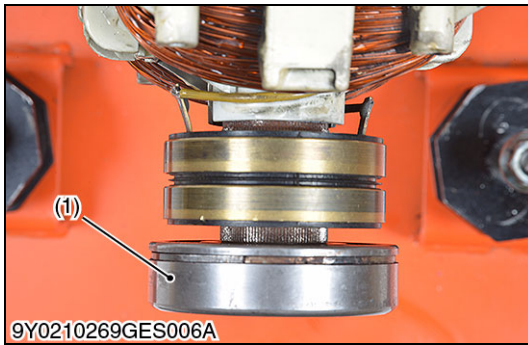

Checking Generator's Ball Bearing

1. Hold the bearing (1), and push and pull the outer race in all directions to check for wear and roughness.
2. Turn the outer race to check rotation.
3. If there is any defect, replace it.

(1) Ball Bearing

W1027220

(4) Exciter Coil



Exciter Field Winding (Sub Coil)

1. Measure the coil resistance between each lead with a miliohm meter.
2. If the resistance is not as specified, replace the stator or contact service station.
(Refer to "5. WIRING DIAGRAM" (2-M8).)

Resistance	Factory spec.	Refer to "2. SERVICING SPECIFICATION" (2-S6).
------------	---------------	---

W1027306

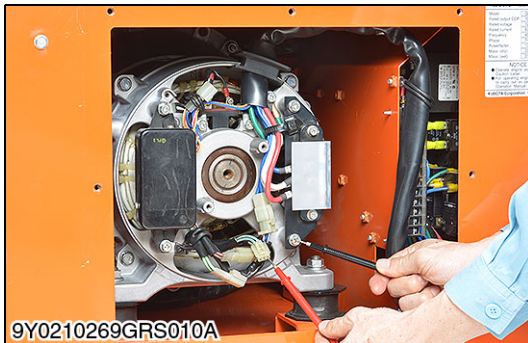

Grounding of Exciter Field Coil (Sub Coil)

1. Measure the insulation resistance between each lead and the laminations with a megohm meter.
2. A reading should be more than 1 MΩ at 500 V.
3. If continuous, replace the exciter coil assembly or contact service station.

W1027430

(5) Sub Coil (DC)

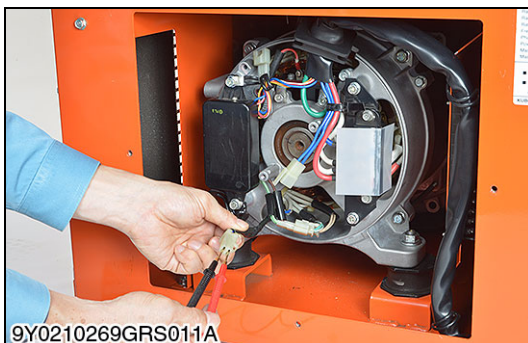

Sub Coil (DC)

1. Measure the coil resistance between each lead with a miliohm meter.
2. If the resistance is not as specified, replace the stator or contact service station.
(Refer to "5. WIRING DIAGRAM" (2-M8).)

Resistance	Factory spec.	Refer to "2. SERVICING SPECIFICATION" (2-S6).
------------	---------------	---

W1031564

Editor : Farm and Industrial Machinery International Service Department
Address : 64, Ishizu-Kitamachi, Sakai-Ku, Sakai-City, Osaka, 590-0823, Japan
Phone : +81-72-241-1129
Fax : +81-72-245-2484
E-mail : ks_g.ksos-pub@kubota.com
