



DCA40SSKU4F2

MQ POWER Series Generator

WhisperWatt™

Prime Rating — 28.8 kW (36 kVA)

Standby Rating — 30.2 kW (37.8 kVA)

Three-Phase, 60 Hertz, 0.8 PF

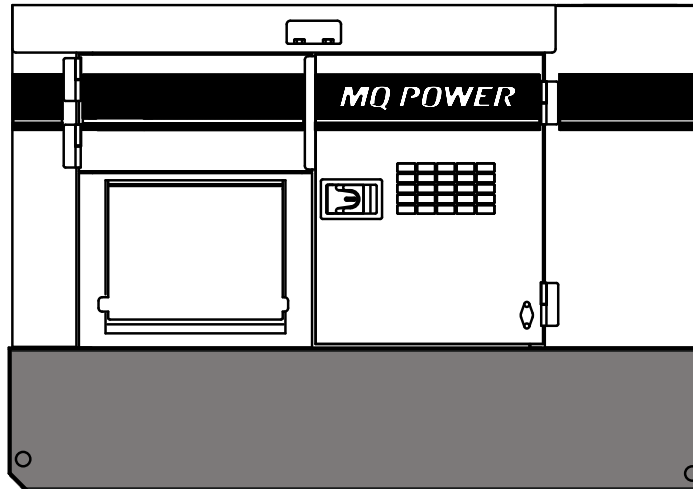

STANDARD FEATURES

- Heavy duty, 4-cycle, direct injection, turbocharged, diesel engine provides maximum reliability.
- Brushless alternator reduces service and maintenance requirements and meets temperature rise standards for Class H insulation systems.
- Open delta excitation design provides virtually unlimited excitation for maximum motor starting capability.
- Automatic voltage regulator (AVR) provides precise regulation.
- Electronic Governor Control — maintains frequency to within $\pm 0.25\%$ from no load to full load.
- Full load acceptance of standby nameplate rating in one step (NFPA 110, para 5-13.2.6).
- Sound attenuated, weather resistant, steel housing provides operation at 63 dB(A) at 23 feet. Fully lockable enclosure allows safe unattended operation.
- Internal fuel tank with direct reading of fuel gauge.
- E-coat and powder-coat paint system provides durability and weather protection.
- Fuel/water separator removes condensation from fuel for extended engine life. Panel mounted alarm light included.
- Complete engine analog instrumentation includes fuel level gauge, hour meter, preheat indicator, and emergency shutdown monitors.
- Automatic Start/Stop Control — automatically starts the generator set during a commercial power failure when used in conjunction with a transfer switch.
- Complete generator analog instrumentation includes voltage regulator control, ammeter phase selector switch, AC voltmeter, AC ammeter, frequency meter, and circuit breaker.
- Automatic safety shutdown system monitors the water temperature, engine oil pressure, overspeed and overcrank. Warning lights indicate abnormal conditions.
- Complete power panel. Fully covered; three-phase terminals and single phase receptacles allow fast and convenient hookup for most applications including temporary power boxes, tools and lighting equipment. The GFCI receptacles are NEMA 5-20, and the auxiliary outputs use CS6369 twist-lock receptacles.
- Simultaneous single and three-phase power.
- Voltage selector switch offers the operator a wide range of voltages that are manually selectable. Fine tuning of the output voltage can be accomplished by adjusting the voltage regulator control knob to obtain the desired voltage.
- EPA emissions certified — Tier 4 final emissions compliant.
- Engine fitted with DOC.
- Spill containment — bunded design protects environment by capturing up to 132% of engine fluids.



DCA40SSKU4F2

MQ POWER Series Generator

SPECIFICATIONS

Generator Specifications		
Design	Revolving field, self-ventilated Drip-proof, single bearing	
Armature Connection	Star with Neutral	Zig Zag
Phase	3	Single
Standby Output	30.2 KW (37.8 KVA)	27.3 KW
Prime Output	28.8 KW (36 KVA)	26 KW
Voltage - 3Ø	208, 220, 240, 416, 440, 480 V	N/A
Voltage - 1Ø	N/A	120, 240 V
Power Factor	0.8	1
Voltage Regulation (No load to full load)	±0.5%	
Generator RPM	1800	
Frequency	60 Hz	
No. of Poles	4-pole	
Excitation	Brushless with AVR	
Frequency Regulation: Steady State	±0.25% of mean value for constant loads from no load to full load.	
Insulation	Class H	
Sound Level dB(A) Full load at 23 feet	63	

Engine Specifications	
Make / Model	Kubota / V2403-CR-TIE4BG
Emissions	EPA Tier 4 Final Certified
Starting System	Electric
Design	4-cycle, water cooled, direct injection, charge air cooled, EGR, ECM, and DOC
Displacement	148.5 in ³ (2434 cc)
No. cylinders	4
Bore x Stroke	3.42 x 4.01 in. (87 x 102 mm)
Gross Engine Power Output	48.3 hp (36 kW)
BMEP	145 psi (1000 kPa)
Piston Speed	1209 ft./min. (6.14 m/s)
Compression Ratio	16.0:1
Engine Speed	1800 rpm
Overspeed Limit	2070 rpm
Oil Capacity	2.5 gallons (9.7 liters)
Battery	12V 72Ah x 1

Fuel System		
Recommended Fuel	ASTM-D975-No.1 & No.2-D*	
Maximum Fuel Flow (per hour)	2.4 gallons (9.1 liters)	
Maximum Inlet Restriction (Hg)	8.86 in. (225 mm)	
Fuel Tank Capacity	67.4 gallons (255 liters)	
Fuel Consumption	gph	lph
At full load	2.3	8.7
At 3/4 load	1.8	6.7
At 1/2 load	1.3	5.1
At 1/4 load	0.8	3.0

* - Use ultra-low sulfur diesel fuel.

Exhaust System	
Gas Flow (full load)	155 cfm (4.4 m ³ /min)
Gas Temperature	918°F (492°C)
Maximum Back Pressure	26.9 in. H ₂ O (6.7 kPa)

Cooling System	
Fan Load	0.62 hp (0.46 kW)
Coolant Capacity (with radiator)	4.75 gallons (18 liters)
Coolant Flow Rate (per minute)	17.7 gallons (67 liters)
Heat Rejection to Coolant (per minute)	1681 Btu (1.77 MJ)
Ambient Temperature Rating	104°F (40°C)

Air	
Combustion Air	88.3 cfm (2.5 m ³ /min)
Maximum Air Cleaner Restriction	25 in. H ₂ O (6.23 kPa)
Alternator Cooling Air	526 cfm (14.9 m ³ /min)
Radiator Cooling Air	1656 cfm (46.9 m ³ /min)

Amperage	
Rated Voltage	Maximum Amps
1Ø 120 Volt	80 Amps (4 wire) 108 A x 2 (Zigzag)
1Ø 240 Volt	40 Amps (4 wire) 108 A (Zigzag)
3Ø 240 Volt	86 Amps
3Ø 480 Volt	43 Amps
Main Line Circuit Breaker Rating	110 Amps
Over Current Relay Trip Set Point 480V Mode Only	43 Amps

WARRANTY*

Kubota Engine

12 months from date of purchase with unlimited hours or 24 months from date of purchase with 2000 hours (whichever comes first).

Generator

24 months from date of purchase or 2000 hours (whichever occurs first).

Trailer

12 months excluding normal wear items.

* Refer to the express written, one-year limited warranty sheet for additional information.

NOTICE

Specifications sheet is subject to change and is not intended for use in installation design.



DCA40SSKU4F2

MQ POWER Series Generator

MQ POWER DECIBEL LEVELS

Our soundproof housing allows substantially lower operating noise levels than competitive designs. WhisperWatts are at home on construction sites, in residential neighborhoods, and at hospitals — just about anywhere.

- 90 — Subway / truck traffic
- 80 — Average city traffic
- 70 — Inside car at 60 mph
- 63.0 — **WhisperWatt at 23 feet**
- 60 — Air conditioner at 20 feet
- 50 — Normal conversation



GENERATOR OUTPUT PANEL

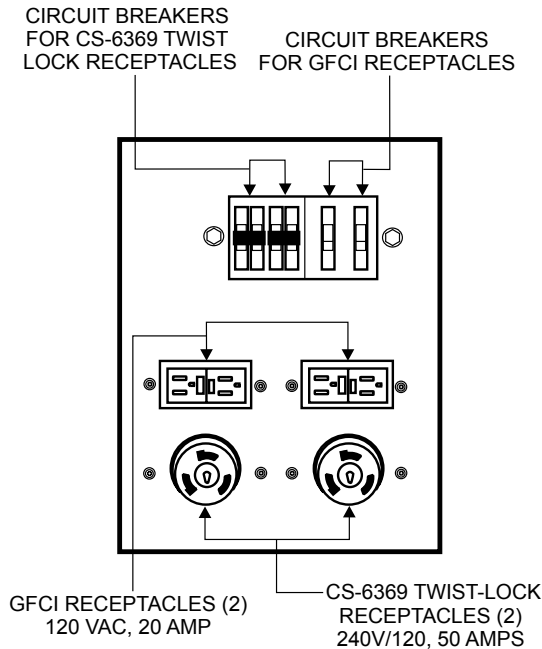

OPTIONAL GENERATOR FEATURES

- **Battery Charger** — provides fully automatic and self-adjusting charging to the generator's battery system.
- **Jacket Water Heater** — for easy starting in cold weather climates.
- **Special Batteries** — long life batteries provide extra engine cranking power.
- **Trailer Mounted Package** — meets National Highway Traffic Safety Administration (NHTSA) regulations. Trailer is equipped with electronic or surge brakes with double axle configuration.

OPTIONAL CONTROL FEATURES

- **Emergency Stop Switch** — when manually activated shuts down generator in the event of an emergency.
- **Audible alarm** — alerts operator of abnormal conditions.

OPTIONAL OUTPUT CONNECTIONS

- **Cam-Lok Connectors** — provides quick disconnect alternative to bolt-on connectors.
- **Pin and Sleeve Connectors** — provides industry standard connectors for all voltage requirements.
- **Output Cable** — available in any custom length and size configuration.



DCA40SSKU4F2

MQ POWER Series Generator

DIMENSIONS

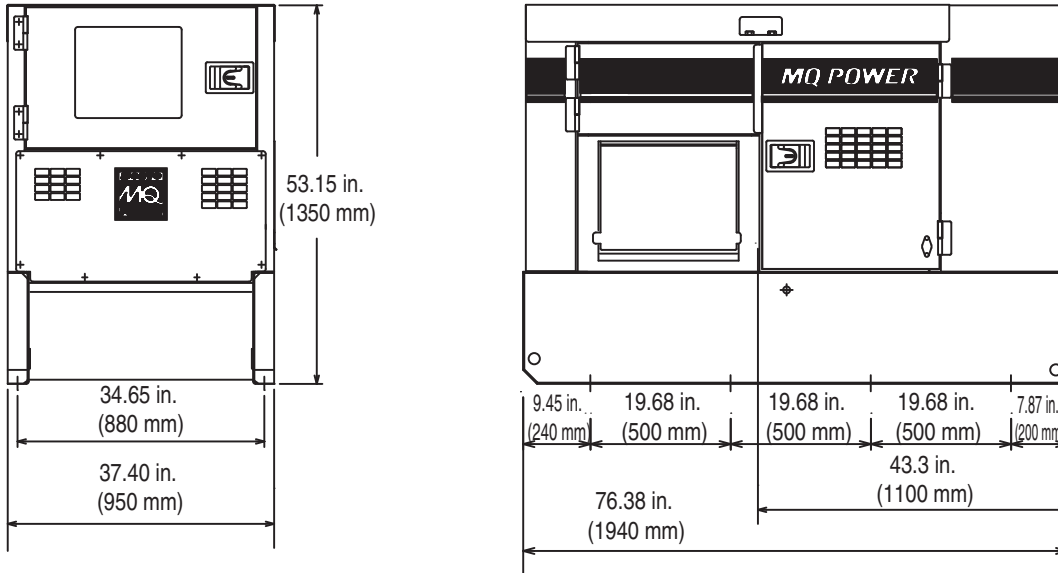

Weight	
Dry Weight	2,205 lbs. (1000 kg)
Wet Weight	2,735 lbs. (1,240 kg)
Max. Lifting Point Capacity	5,150 lbs. (2,315 kg)

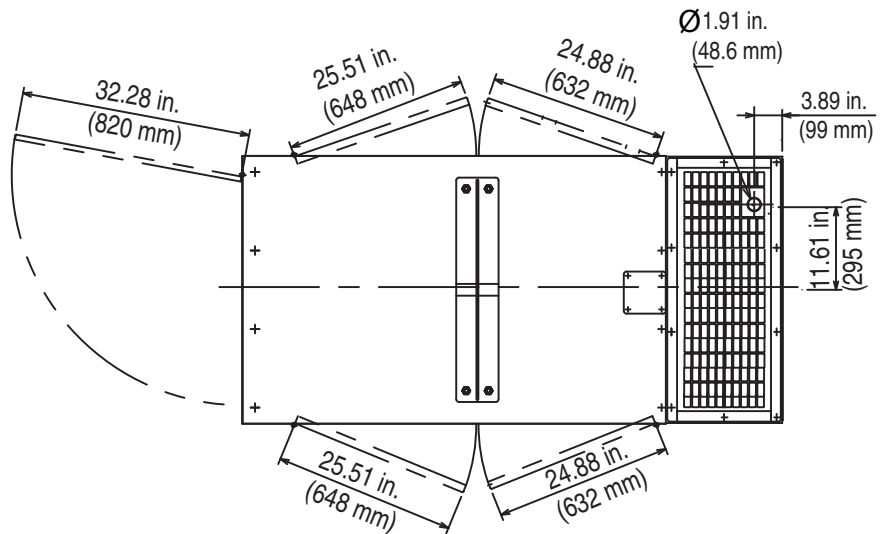

Generator can be placed on MQ Power Model TRLR45 Trailer.

Manufactured by Denyo Co.

Your MultiQuip dealer is:

