



# Installation Manual

## Onan Generator Set for Commercial Mobile

HDKBA (Spec A–D)

HDKBB (Spec A–J)

HDKBC (Spec D–J)



# Table of Contents

---

<b>TABLE OF CONTENTS</b> .....	<b>ii</b>
<b>SAFETY PRECAUTIONS</b> .....	<b>1</b>
<b>INTRODUCTION</b> .....	<b>9</b>
About this Manual .....	9
Outline Drawings .....	9
Installation Codes and Standards for Safety .....	10
Noise .....	10
Electromagnetic compatibility .....	10
<b>MOUNTING, LOCATION AND VENTILATION</b> .....	<b>11</b>
Mounting .....	11
Location .....	11
Ventilation .....	12
<b>EXHAUST CONNECTIONS</b> .....	<b>13</b>
Muffler .....	13
Tailpipe .....	14
<b>FUEL CONNECTIONS</b> .....	<b>17</b>
Bio-diesel Fuels B5 – B20 .....	18
<b>ELECTRICAL CONNECTIONS</b> .....	<b>21</b>
AC Power Connections .....	21
Remote Control Connections .....	23
Battery Connections .....	23
<b>INSTALLATION REVIEW AND STARTUP</b> .....	<b>27</b>
Hot Air Recirculation Test .....	27
Installation Review .....	28
Startup .....	28
<b>SPECIFICATIONS</b> .....	<b>29</b>
Figure 15. Outline Drawing—Sheet 1 .....	31
Figure 16. Outline Drawing—Sheet 2 .....	31
Figure 17. Wiring Diagram—Sheet 1 .....	32
Figure 18. Wiring Diagram—Sheet 2 .....	33

**This Page Intentionally Left Blank.**

# SAFETY PRECAUTIONS

---

Thoroughly read the **OPERATOR'S MANUAL** before operating the generator set. Safe operation and top performance can only be obtained when equipment is properly operated and maintained.

Only trained and experienced service personnel with knowledge of fuels, electricity, and machinery hazards shall remove, dismantle and dispose of the generator set. See service manual.

Some generator set installation procedures present hazards that can result in severe personal injury or death. Only trained and experienced personnel with knowledge of fuels, electricity, and machinery hazards should perform generator set installation procedures.

The following symbols in this manual alert you to potential hazards to the operator, service person and equipment.

**⚠ DANGER** *Used to alert you to a lethal hazard against which you must take steps to prevent severe personal injury or death, as when you are in the vicinity of High Voltage equipment.*

**⚠ WARNING** *Used to alert you to a hazard or unsafe practice that can result in severe personal injury or death.*

**⚠ CAUTION** *Used to alert you to a hazard or unsafe practice that can result in personal injury or equipment damage.*

Electricity, fuel, exhaust, moving parts and batteries present hazards which can result in severe personal injury or death.

## ENGINE EXHAUST IS DEADLY

- Inspect for exhaust leaks at every startup and after every eight hours of running.
- Prior to every startup and after every eight hours of running, all carbon monoxide detectors must be tested and confirmed to be working in accordance with the manufacturer's instructions or owners manual.
- Learn the symptoms of carbon monoxide poisoning in the generator set Operator's Manual.
- Never occupy the vehicle while the generator set is running unless the vehicle is equipped with a working carbon monoxide detector.

- Do not operate the generator set when the vehicle is parked in a confined space, such as a garage.
- Disable the automatic generator set starting feature (AGS) of an inverter-charger or other automatic starting device before storing the vehicle or parking it in a garage or other confined space.
- The exhaust system must be installed in accordance with the generator set Installation Manual.
- Engine cooling air must not be used for heating the vehicle.

## GENERATOR SET VOLTAGE IS DEADLY

- Disable the automatic generator set starting feature (AGS) of an inverter-charger or other automatic starting device before servicing the generator set.
- generator set electrical output connections must be made by a trained and experienced electrician in accordance with applicable codes.

**⚠ WARNING** *Interconnecting the generator set and shore power can lead to electrocution of utility line workers, equipment damage and fire. Use an approved switching device to prevent interconnections.*

- Use caution when working on live electrical equipment. Remove jewelry, make sure clothing and shoes are dry, stand on a dry wooden platform or rubber insulating mat and use tools with insulated handles.

## DIESEL FUEL IS COMBUSTIBLE

- Do not smoke or turn electrical switches ON or OFF where fuel fumes are present or in areas sharing ventilation with fuel tanks or equipment. Keep flames, sparks, pilot lights, arc-producing equipment and all other sources of ignition well away.
- Fuel lines must be secured, free of leaks and separated or shielded from electrical wiring.

## MOVING PARTS CAN CAUSE SEVERE PERSONAL INJURY OR DEATH

- Disable the automatic generator set starting feature (AGS) of an inverter-charger or other auto-

matic starting device before servicing the generator set.

- Do not wear loose clothing or jewelry near moving parts such as PTO shafts, fans, belts and pulleys.
- Keep hands away from moving parts.
- Keep guards in place over fans, belts, pulleys, and other moving parts.

### **BATTERY GAS IS EXPLOSIVE**

- Wear splash-proof safety glasses.
- Do not smoke or permit flames or sparks to occur near the battery at any time.
- To reduce arcing when disconnecting or reconnecting battery cables, always disconnect the negative (-) battery cable first and reconnect it last.

### **FLAMMABLE VAPOR CAN CAUSE A DIESEL ENGINE TO OVERSPEED**

**⚠WARNING** *Do not operate a diesel-powered generator set where a flammable vapor environment can be created by fuel spill, leak, etc.*

Flammable vapor can cause a diesel engine to overspeed and become difficult to stop, resulting in possible fire, explosion, severe personal injury and death. The owners and operators of the generator set are solely responsible for operating the generator set safely.

### **GENERAL PRECAUTIONS**

- Keep children away from the generator set.
- Do not use evaporative starting fluids. They are highly explosive.
- To prevent accidental or remote starting while working on the generator set, disconnect the negative (-) battery cable at the battery.
- Let the engine cool down before removing the coolant pressure cap or opening the coolant drain. Hot coolant under pressure can spray out and cause severe burns.
- Use personal protective equipment when installing generator set (gloves, safety glasses, etc).
- Keep the generator set and its compartment clean. Excess oil and oily rags can catch fire. Dirt and gear stowed in the compartment can restrict cooling air.

- Make sure all fasteners are secure and torqued properly.
- Do not work on the generator set when mentally or physically fatigued or after consuming alcohol or drugs.
- Used engine oil has been identified by some U. S. state and federal agencies as causing cancer or reproductive toxicity. Do not ingest, inhale, or contact used oil or its vapors.
- Ethylene glycol, used as engine antifreeze, is toxic to humans and animals. Clean up spills and dispose of used engine coolant in accordance with local environmental regulations.
- Keep multi-purpose fire extinguishers handy. Multi-purpose fire extinguishers are used for fires that involve ordinary combustible materials such as wood and cloth; combustible and flammable liquid fuels and gaseous fuels; live electrical equipment. (North America or US: ref. NFPA No. 10)
- generator set installation and operation must comply with all applicable local, state and federal codes and regulations.
- generator sets with a sound shield shall not be run with the service doors remove/missing.
- Engine components can be hot and cause severe burns. Hot coolant under pressure can spray and cause severe burns.
- Use personal protective equipment when maintaining or installing the generator set such as gloves, safety glasses, etc.

### **THE HAZARDS OF CARBON MONOXIDE**

**⚠WARNING** *Engine-driven generator sets can produce harmful level of carbon monoxide that can injure or kill you.*

### **ONLY YOU CAN PROTECT YOURSELF FROM CO POISONING!**

- Watch constantly for people near the exhaust of the generator set while it is running.
- Make sure exhaust cannot enter the living quarters through a window, vent or door.
- Make sure all CO detectors and audible alarms are working properly.
- Pay attention to the signs of CO poisoning.

- Check the exhaust system for corrosion, obstruction and leaks each time you start the generator set and every eight hours if you run it continuously.

## **SUBSTANCE HAZARDOUS TO HEALTH**

generator sets use substances, and emit and create wastes that can cause health risks. generator set operators must use appropriate personal protective equipment (such as clothing, gloves, protective glasses/goggles, and respiration equipment) when exposed to fuel, oil, coolant, wet batteries, grease, cleaning agents, or other substances exposed to lungs, eyes, or skin. use appropriate containers for transport, storage, and disposal of waste substances. Follow local regulations for disposal and recycling.

### **ANTIFREEZE (FLEETGUARD – ES COMPLEAT/EG PREMIX)**

This antifreeze is also known as an ethylene glycol based coolant; summer coolant; coolant additive. It is purple coloured, viscous liquid, with a mild chemical odour, is soluble in water and harmful. It contains ethylene glycol, and diethylene glycol. Ethylene glycol is a potentially hazardous constituent.

The substance has a boiling point of 107° C, and a flash point of 121° C.

It is used as an engine coolant additive, and can be found in engine cooling systems, and head exchangers. Installers, operators and maintainers are likely to encounter this substance.

## **HAZARDOUS REACTIONS**

Ethylene glycol is combustible when exposed to heat or flame and can react vigorously with oxidants. Moderate explosive hazard in form of vapour when exposed to heat or flame. Hazardous products resulting from combustion or decomposition include carbon monoxide, carbon dioxide and acrid smoke. Self-contained breathing apparatus must be worn in the event of fume build up.

Avoid strong oxidizing agents – incompatible with sulfuric acid, nitric acid, caustics and aliphatic amines.

It may cause neurological signs and symptoms, and kidney damage. It is also a skin and eye irritant.

Very toxic in particulate form upon inhalation. Harmful if swallowed, lethal dose for humans reported to be 100ml.

## **PROTECTIVE MEASURES**

Refrain from eating, drinking or smoking when using the product. Adopt a high standard of personal hygiene. In case of skin contact, wash immediately with soap and water.

Ensure good ventilation and avoid heat sources. Avoid breathing mist, if there is a risk of vapour, or particulate, use a suitable organic vapour mask.

Eye protection, gloves, overalls, impervious apron should be used. Avoid contamination inside the gloves. If overalls become contaminated, discontinue use and clean thoroughly.

## **STORAGE/TRANSPORT**

Store and transport only in correctly marked containers. Keep containers closed when not in use. Keep cool, out of sunlight, away from naked flames and strong acids, do not freeze. Store well away from food-stuffs and drinking water. Take special care to avoid discharge into drains, sewers and water-courses.

Contain leak/spill with sand, earth or non-combustible, absorbent material to prevent entry of substance into drainage/sewerage system, water-courses and land. Eliminate all ignition sources, use plastic shovel to transfer to suitable container and dispose of unwanted or absorbed substance through and authorized contractor to a licensed site.

## **EMERGENCY ACTION**

- Fire  
Extinguishing media: CO<sub>2</sub>, alcohol resistant foam, dry powder, or water spray.  
Fire fighters to use self contained breathing apparatus. Keep fire exposed containers cool. Prevent run-off from entering waterways, drains and drinking water supplies.
- Ingestion  
Toxic by ingestion. If swallowed induce vomiting only under the advice of a Doctor or poison control centre. Delayed treatment may result in fatality.

- Inhalation (of vapour)  
Remove from further exposure. In case of irritation to lungs or throat, seek medical advice.
- Aspiration (inhalation of liquid)  
Obtain immediate medical assistance.
- Eyes  
Flush copiously with water or preferably eye-wash solution for at least five minutes. Seek medical advice.
- Skin  
Wash thoroughly with soap and water, and seek medical attention if irritation develops. Change clothing if necessary and wash before re-use.
- Spillage  
Soak-up using an absorbent material and dispose of this as directed under Storage/Transport (Section 5.1.3)

## **GAS OIL**

This product is also known as Red Diesel, Fuel Oil, and type A1 or A2. It can be pale red or a clear liquid with a characteristic mild odour. It contains catalytically cracked oil, petroleum distillates, quinizarin, and gas oil maker dye red. The catalytically cracked oil and petroleum distillates are potentially hazardous constituents.

The substance has an initial boiling point of 180°C, a flash point greater than 56°C, and a vapour pressure less than 0.7mm Hg at 20°C and has negligible solubility in water.

It is used as a fuel for off-road diesel powered vehicles and stationary engines, and can be found in fuel tanks, pipes and injection systems. The substance should not be used for any other purpose without contacting the manufacturer or supplier. Installers, operators and maintainers are likely to encounter this substance.

## **HAZARDOUS REACTIONS**

This liquid is flammable. Avoid smoking, heat sources, such as welding and naked flames, sparks and static electricity build-up. Thermal decomposition products are hazardous, containing CO<sub>x</sub>, NO<sub>x</sub> and SO<sub>x</sub> compounds.

The vapour is explosive. High vapour concentrations can cause respiratory irritation, dizziness, nausea, and loss of consciousness. Excessive and prolonged exposure to the mist can cause chronic in-

flammatory reaction of the lungs and form of pulmonary fibrosis.

Avoid strong oxidizing agents, e.g. chlorates which may be use in agriculture.

Gas oil is slightly irritating to the skin and has a de-fatting action. Toxicity following single exposure to high level of gas oil is of low order. Prolonged, repeated skin contact may de-fat the skin resulting in possible skin irritation and dermatitis. In some cases warty, cancerous growths have occurred.

## **PROTECTIVE MEASURES**

Ensure good ventilation and avoid heat sources. Observance of good housekeeping rules will ensure general safety. Do not smoke. Avoid breathing mist.

When working on, or testing, injection equipment, special care is required to avoid perforation of skin by high pressure fuel. Use eye protection in the event of suspected high pressure leak.

Adopt a high standard of personal hygiene. In the case of skin contact, wash well with soap and water.

Use glove and overalls, and eye protection goggles if there is a risk of splashing. Use oil impervious gloves and avoid contamination inside the gloves. If overalls become contaminated, discontinue use and clean thoroughly. Contaminated clothing should be removed, soaked with water, and laundered before re-use.

No special respiratory precautions are necessary in normal use.

DO NOT use as a solvent for removing dirt/grease etc, from skin.

## **STORAGE/TRANSPORT**

Store and transport only in correctly marked containers. Keep containers closed when not in use. Keep cool, out of sunlight and away from naked flames. Electrical continuity is required between the transport and storage vessels during product transfer.

Contain leak/spill with sand, earth or other suitable material, and prevent entry of substance into drainage/sewerage system, water-courses and land. Dispose of unwanted or absorbed substance through an authorized contractor to a licensed site.



Inform local and fire authorities should the product reach waterways, drains etc.

## EMERGENCY ACTION

- Fire  
Extinguishing media:  
Large fire – Foam/water fog. Never use water jet.  
Small fire – foam/dry powder, AAAF, CO<sub>2</sub>, sand, earth.  
Avoid making sparks. Fire fighters to use self-contained breathing apparatus. Keep fire exposed containers cool, using water fog/spray. Prevent run-off from entering waterway, drains and drinking water supplies.
- Ingestion  
Do not induce vomiting. Wash the mouth out with water, and send to hospital immediately.
- Inhalation (of vapour)  
Remove from further exposure. Obtain medical assistance immediately.
- Aspiration (inhalation of liquid)  
If, following ingestion of gas oil, vomiting occurs, there is danger of aspiration into the lungs. This would cause intense local irritation and chemical pneumonitis that can be fatal. Obtain immediate medical assistance.
- Eyes  
Irrigate copiously with water or preferably eye-wash solution for at least five minutes. If irritation persists seek medical advice.
- Skin  
Wash thoroughly with soap and water. Change clothing if necessary.  
If high pressure injection has occurred prompt surgical attention is required.
- Spillage  
Absorb using sand, earth or other suitable material. Dispose of unwanted or absorbed flammable material as directed under Storage/Transport (Section 5.7.3).

## LUBRICATION OIL – PREMIUM BLUE E 15W40

Also known as oil, lube oil, sump oil, new oil is dark, viscous liquid with a slight, characteristic odour. The base oil contains: distillates (petroleum), solvent-dewaxed heavy paraffinic. It is not classified as dangerous according to Directive 1999/45/EC and its amendments, and is not classified according to the EU regulations.

It has a boiling point greater than 150°C, a flash point Open Cup of 220°C (Cleveland), and is insoluble in cold water.

It is used in engine lubricant oil systems, sump pan and filters, make-up tanks and piping systems as a lubrication oil for use in wide range of diesel engines operating under severe conditions. Installers, operators and maintainers are likely to encounter this product.

## HAZARDOUS REACTIONS

This product is stable although slightly re-active with oxidizing agents. Results of decomposition are carbon oxides (CO, CO<sub>2</sub>) and water.

Although harmful if swallowed or aspirated (breathed in), repeated or prolonged exposure is not known to aggravate medical conditions.

Used oil may contain harmful combustion by-products and unburnt fuel that will cause skin reactions as detailed for fuel. Particular care must be taken if oil from a severely overheated engine is handled – use impervious gloves, lab coat and safety glasses.

Do not breathe vapour/spray.

## PROTECTIVE MEASURES

Ensure good ventilation and avoid heat sources.

Adopt a high standard of personal hygiene. In case of skin contact, wash thoroughly with soap and water.

Use safety glasses, impervious gloves and lab coat. Avoid contamination inside the gloves. If overalls become contaminated, discontinue use and clean thoroughly.

No special respiratory precautions are necessary in normal use. Do not breathe vapour/spray when handling hot materials.

## STORAGE/TRANSPORT

Store and transport only in correctly marked containers. Keep containers tightly sealed when not in use. Keep in a cool, well ventilated area, out of sunlight and away from naked flames. Store well away from food-stuffs and drinking water.

Wear splash goggles, full suit, boots and gloves. Absorb leak/spill with an inert material and dispose of unwanted or absorbed substance through an authorized contractor to a licensed site. Finish cleaning by

spreading water on the contaminated surface and allow to evacuate through the sanitary system.

### **EMERGENCY ACTION**

- Fire

Extinguishing media:

Large fire – Use water spray, fog or foam. Do not use water jet.

Small fire – Use dry chemical powder or CO<sub>2</sub>

Fire-fighters to use self contained breathing ap-

paratus and full turnout gear. Keep fire exposed containers cool.

- Ingestion







Do not induce vomiting, Obtain medical advice immediately.

- Inhalation (of vapour)

Remove from further exposure. Obtain medical attention.

## Generator Set Warning Labels

Warning signs are provided on the generator set at or near the point of risk. To avoid injury, always take the necessary precautions – as indicated on the sample signs shown below:

	Caution / Warning. Indicates a risk of personal injury.
	Caution / Warning of Temperature Hazard. Indicates a risk of personal injury from high temperature.
	Caution / Warning of High Voltage Hazard. Indicates a risk of personal injury from electric shock/electrocution.
	Caution / Warning. Indicates a risk of personal injury from equipment that may be subject to automatic starting or remote starting.
	Caution / Warning. Indicates to read Operator manual for additional information.
	Caution / Warning of Belt and Rotating Part Hazard. Indicates a risk of personal injury from entanglement in moving parts.
	Caution / Warning of Pressure Hazard. Indicates a risk of personal injury from pressurized fluids.

**THIS PAGE IS INTENDED TO BE BLANK**

# Introduction

---

## ABOUT THIS MANUAL

**⚠️WARNING** *Improper installation can result in severe personal injury, death and equipment damage. The installer must be qualified to perform the installation of electrical and mechanical equipment.*

**⚠️WARNING** *This generator set is not a life support system. It can stop without warning. Children, persons with physical or mental limitations, and pets could suffer personal injury or death. A personal attendant, redundant power or an alarm system must be used if generator set operation is critical.*

**⚠️WARNING** *This generator set is not “ignition protected” and shall not be used in a flammable vapor environment.*

**⚠️CAUTION** *Unauthorized modifications or replacement of fuel, exhaust, air intake or speed control system components that affect engine emissions are prohibited by law in the State of California.*

This manual is a guide for the installation of the generator sets listed on the front cover. Proper installation is essential for top performance. Read through this manual before starting the installation.

This manual addresses the following aspects of the installation:

- Location and Mounting
- Exhaust Connections
- Fuel Connections
- Electrical Connections
- Startup

See the Operator’s Manual for operation and maintenance and the Service Manual for service.

Manuals are updated from time to time to reflect changes in the equipment and its specifications. For this reason, only the copy of the installation manual supplied with the generator set should be used as a guide for the installation.

## OUTLINE DRAWINGS

See the Outline Drawings (Pages 33 and 34) for installation details: mounting bolt hole locations, connection points (fuel, battery, exhaust, remote control, AC output), sizes and types of fittings, cooling air openings, weight, and overall dimensions. See your Cummins dealer for a large-scale Outline Drawing and full-size floor cutout template.

## INSTALLATION CODES AND STANDARDS FOR SAFETY

**⚠ CAUTION** *The Commercial generator set Warranty applies only when the generator set is installed in a Commercial or Recreational Vehicle.*

The generator set installer bears sole responsibility for the selection of the appropriate generator set, for its proper installation and for obtaining approvals from the authorities (if any) having jurisdiction over the installation.

Federal, State and local codes, such as the California Administrative Code—Title 25 (RV installation), might also be applicable. Installation codes and recommendations can change from time-to-time and are different in different countries, states and municipalities. It is recommended that the standards in Table 1 be obtained for reference.

**TABLE 1. REFERENCE CODES AND STANDARDS**

Code of Federal Regulations: Title 49: Chapter III, Chapter V	Superintendent of Documents P. O. Box 371954 Pittsburgh, PA 15250-7954
National Electrical Code: NFPA No 70, 1192	National Fire Protection Association 470 Atlantic Avenue Boston, MA 02210
ANSI/RVIA-EGS-1	Recreational Vehicle Industry Association 14650 Lee Road Chantilly, VA 22021
California Administrative Code: Title 25, Chapter 3	State of California Documents Section P.O. Box 1015 North Highlands, CA 95660
CAN/CSA-Z240: Recreational Vehicles Bulletin 946	Canadian Standards Association Housing & Construction Materials 178 Rexdale Blvd. Rexdale, Ontario, Canada M9W 1R3
IEC 60364-7-708: Electrical Installations in Caravan Parks & Caravans	International Electrotechnical Commission 3, Rue de Varembe Geneva, Switzerland

## NOISE

generator sets emit noise. As noise level and time of exposure increase, risk of hearing damage increases. The Specifications page in the Operator manual states noise level for this generator set. Select and use personal hearing protection appropriate for your exposure to generator set noise.

Note for use in countries where compliance to the EU Noise directive is required: This generator set has not been evaluated and is not marked for use in open air. Install the generator set in accordance with the Installation manual. Obey local noise restrictions when you operate the generator set.

## ELECTROMAGNETIC COMPATIBILITY

generator sets emit and receive electromagnetic (radio frequency) energy. If the generator set affects operation of nearby devices, or nearby devices affect generator set operation, increase the distance between them.

Note for use in countries where compliance to the EMC directive is required: This generator set has been evaluated for use in residential, commercial, and light industrial environments.

# Mounting, Location and Ventilation

## MOUNTING

***Installation of the generator set requires lifting apparatus. Ensure that correctly rated lifting slings with suitable attachments are available prior to commencing work. Lifting and lowering operations should only be carried out by properly trained personnel. Do not exceed the rating of any lifting component. Wear head, eye, hand and foot protection during lifting operations.***

The generator set has a 2 point lifting system, which is accessible through an access cover. Refer to outline drawing (p 24 and p 25) for the location of the access cover and weight of the generator set. Make provisions accordingly for safe handling.

Support the generator set on a structure able to resist the dynamic weight of the generator set:  $\pm 3$  g-force vertical and  $\pm 1$  g-force horizontal. See *Specifications* for the weight of the generator set. Use four Grade 5 screws (3/8-16 UNC) to secure the generator set to the floor or frame. The screws must protrude at least 1/2 inch (13 mm) but not more than 1 inch (25 mm) into the base, as measured from the bottom surface of the base. Torque the screws to 35 lb-ft (41 N-m).

**⚠️WARNING** ***The generator set support structure must be designed and installed to support the dynamic weight of the generator set. Failure to do so can result in the generator set dropping onto the roadway causing property damage, severe personal injury and death.***

## LOCATION

Typical generator set locations on a vehicle are illustrated in Figure 1.

Provide access to the operator's console to start and stop the generator set and to check for and add engine oil and coolant.

Provide access for connecting and disconnecting fuel lines, battery cables, remote control wiring and AC wiring.

Provide access for removing the front and bottom access covers to perform periodic maintenance in accordance with the Operator Manual. If the generator set compartment has a floor, use the floor cutout template that is available from your Cummins dealer. The crosshatched areas on Page 16 indicate the areas that must be open in the floor. These areas must not be obstructed by frame members, exhaust tail pipes or other equipment.

Make sure the generator set clears the ground by at least 12 inches (305 mm) to provide adequate ventilation and reduce the amount of dust pulled in by the cooling fan.

A generator set compartment must be large enough to provide at least 1/2 inch (12.7 mm) clearance at the top of the generator set, 1/4 inch (6.4 mm) at the back and left side, 2 inches (51 mm) at the front for air intake and 4 inches (102 mm) at the right side for air discharge (Figure 2). These minimum clearances apply to any thermal or acoustic insulation with which the compartment may be lined.

Acoustic/thermal insulation and adhesive must be Classified as "Self-Extinguishing" at not less than 200°F (90°C). Do not line the bottom of the compartment with insulation, which absorbs spilled fuel and oil.

Provide a vapor-tight, fire-resistive barrier between the generator set and the interior of the vehicle. Use approved materials (26 gauge galvanized steel or equivalent). See NFPA 1192 for details.

***EXHAUST GAS IS DEADLY. Construct a suitable vapor barrier of approved materials between the generator set and vehicle interior to keep out exhaust gas.***

Provide protection from rain and snow when the generator set is not mounted in a compartment. The generator set housing is not water tight. Protection must extend over the entire top of the generator set, including the operator control panel.

Provide protection from direct road splash if the generator set is located behind a road wheel or the front grille of the vehicle.

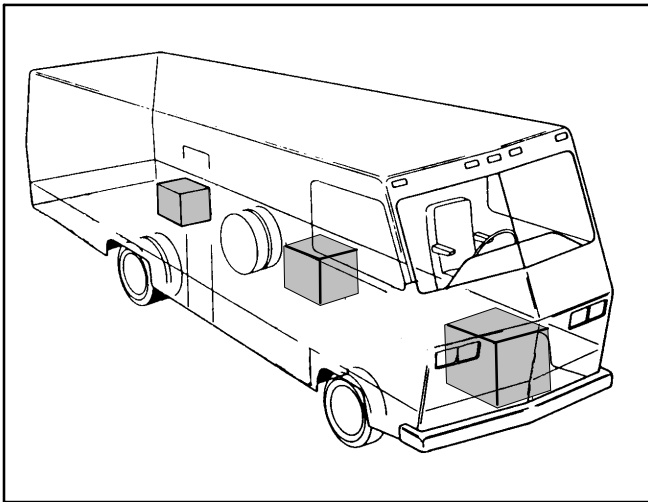

**FIGURE 1. TYPICAL GENERATOR SET LOCATIONS**

### VENTILATION

Unrestricted air flow for cooling, ventilation and combustion (Figure 2) is essential for proper generator set performance and service life. See **HOT AIR RECIRCULATION TEST** (Page 27).

The crosshatched areas on Page 16 must be open for unobstructed air flow into and out of the generator set for cooling, ventilation and combustion.

When the generator set is installed in a compartment that surrounds the top and sides (Figure 2), provide non-flammable baffles (UL 94 HBF foam or better) to prevent hot side-discharge air from recirculating back into the front air inlet grille. The baffles must extend all the way across the top, down the front and half way back below the side air discharge grille. They must close off the gap between the generator set and enclosure.

*If the air inlet is in the compartment door, it must allow the air to flow straight into each opening of the inlet air grille without obstruction (Figure 2).*

*If the air inlet is in the compartment floor in front of the generator set, the opening must be at least 2 inches (51 mm) wide and extend across the entire front of the generator set (crosshatched area, Page 16).*

The compartment outlet for side-discharge air must be at least 4 inches (102 mm) wide and extend across the back half of the floor (Figure 2).

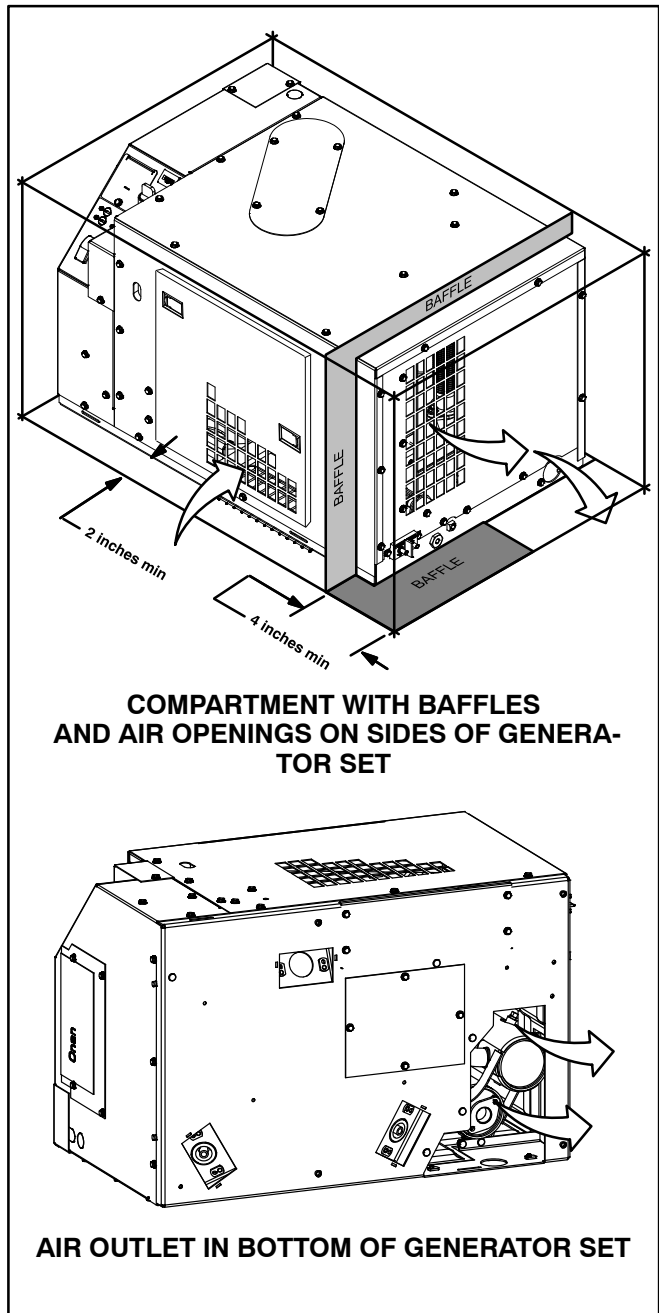

**FIGURE 2. GENERATOR SET COMPARTMENT WITH Baffles TO PREVENT HOT AIR RECIRCULATION**



# Exhaust Connections

The exhaust system must be gas-tight and designed to limit entry of exhaust gases into the vehicle.

**⚠ WARNING** *EXHAUST GAS IS DEADLY! To keep exhaust gases from entering the vehicle do not terminate the exhaust tailpipe underneath the vehicle or closer than specified to openings into the vehicle (Figure 6) or route it such that it is likely to be damaged (Figure 7). Use approved materials and parts only.*

**⚠ CAUTION** *Unauthorized modifications or replacement of fuel, exhaust, air intake or speed control system components that affect engine emissions are prohibited by law in the State of California.*

It has a USDA (Forest Service) spark arrester and meets RVIA EGS-1 construction requirements. The Outline Drawing (Page 16) shows the dimensions of the exhaust flange and the locations of the tailpipe clearance holes.

A generator set without a properly installed and maintained spark arresting exhaust system can cause a brush or forest fire, and is illegal on federal lands. Liability for damage, injury and warranty expense due to the modification of the exhaust system or to use of unapproved parts is the responsibility of the person performing the modification or installing the unapproved parts. Contact a Cummins distributor for approved exhaust system parts.

## MUFFLER

The muffler is mounted inside the generator set housing and has a flanged outlet opening (Figure 3).

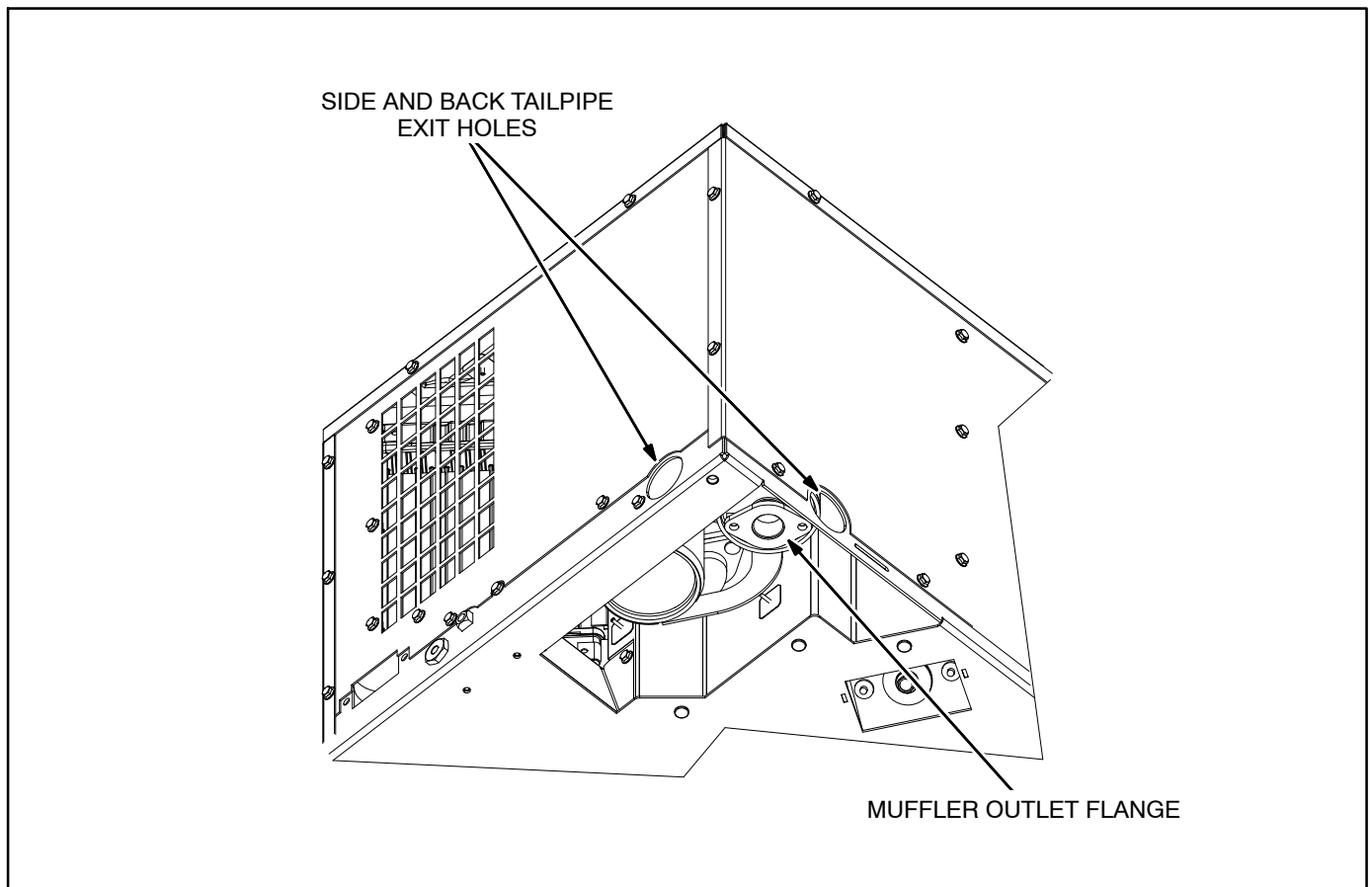

**FIGURE 3. EXHAUST CONNECTIONS AT GENERATOR SET**

## TAILPIPE

The tailpipe of the generator set will be hot during operation and can cause severe burns. To reduce the risk of contact, consideration must be taken on where the tailpipe will be located and routed.

Tailpipe adapter kits are separately available. Use a straight adapter for a tailpipe routed through the bottom. Use an elbow adapter for a tailpipe routed through the side or back exit holes. When connecting and routing the tailpipe:

Use 1-3/8 inch ID 18-gauge aluminized steel tubing or equivalent (minimum 35 mm ID with minimum 0.012 mm wall thickness). Do not use flexible tubing, which is not gas tight or durable.

Secure the tailpipe or adapter flange to the muffler flange with the gasket and two stainless steel bolts supplied in the kit.

Use U-bolt muffler clamps to connect sections of tailpipe. It is recommended that the overlapping pipe be slotted as shown in Figure 4.

Use flexible automotive-type tailpipe hangers every 2 to 3 feet (0.6 to 0.9 m). Attach the hangers to steel framework, not to wood or other combustible material.

Do not terminate the tailpipe underneath the vehicle. Extend it a minimum of 1 inch (25 mm) beyond the perimeter of the vehicle (Figure 5). Support the end of the tailpipe such that it cannot be pushed inward and up under the skirt of the vehicle.

Do not route the tailpipe such that it will interfere with removing the service access cover and performing periodic maintenance. See the Operator Manual.

Do not route the tailpipe closer than 3 inches (76 mm) to combustible material (wood, felt, cotton, organic fibers, etc.) unless it is insulated or shielded. The temperature rise (above ambient) on adjacent combustible material must not exceed 117°F (65°C).

Do not route the tail pipe near fuel lines or fuel tanks.

Do not terminate the tailpipe such that it is closer than 6 inches (153 mm) to any opening into the vehicle interior (door, window, vent). See Figure 6.

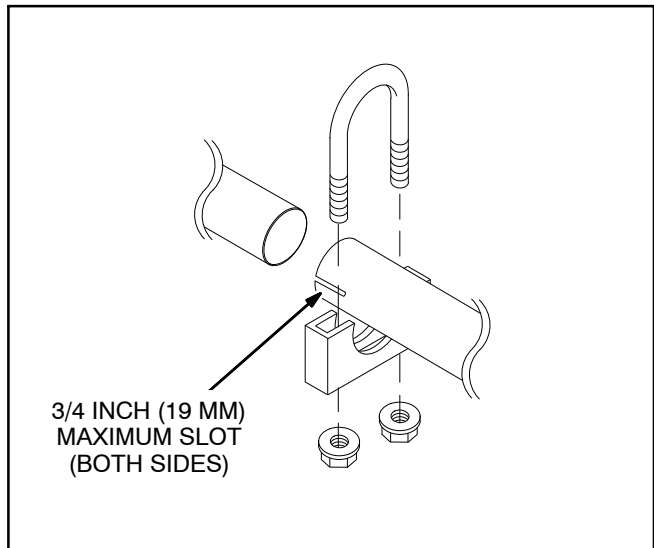

FIGURE 4. EXHAUST TAILPIPE CONNECTIONS

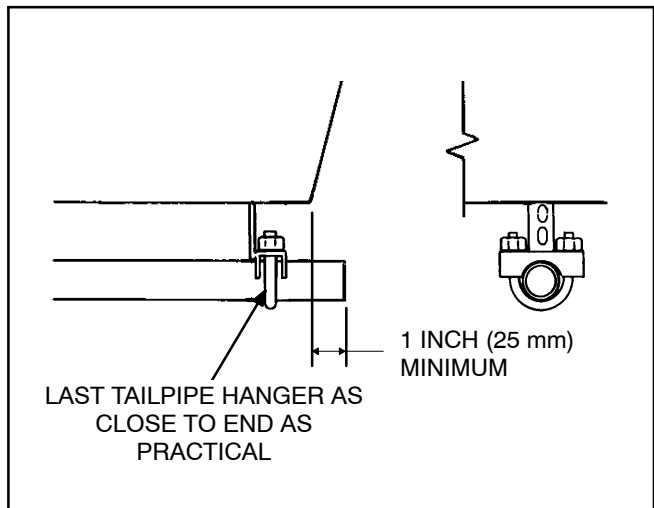

FIGURE 5. TERMINATING THE EXHAUST TAILPIPE

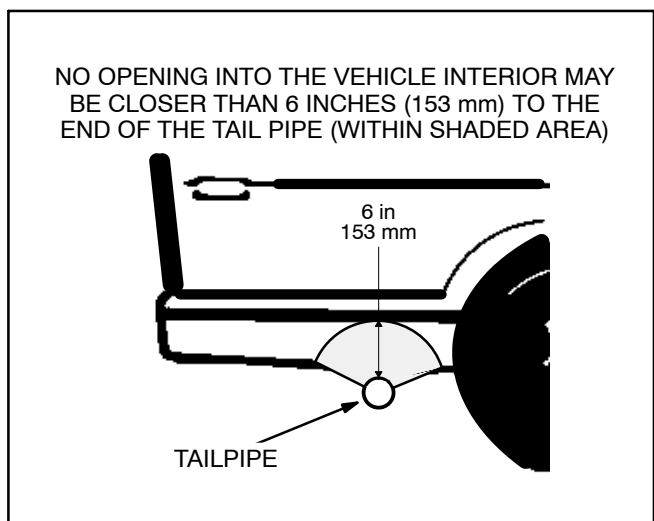

FIGURE 6. MINIMUM DISTANCES TO OPENINGS

Route the tailpipe such that it is not likely to be struck when the vehicle is moving. Keep it out of the ap-

proach and departure angles of the vehicle and above the axle clearance line (Figure 7).

**Interconnecting the engine exhaust systems will allow exhaust condensates and soot to migrate into the engine that is idle, causing engine damage.**

Do not connect the generator set to the vehicle engine exhaust system.

**Excessive back pressure can cause loss of performance and engine damage.**

Exhaust back pressure under full load must not exceed 2 inches (51 mm) water column (WC) as measured within 6 inches (154 mm) of the muffler outlet flange.

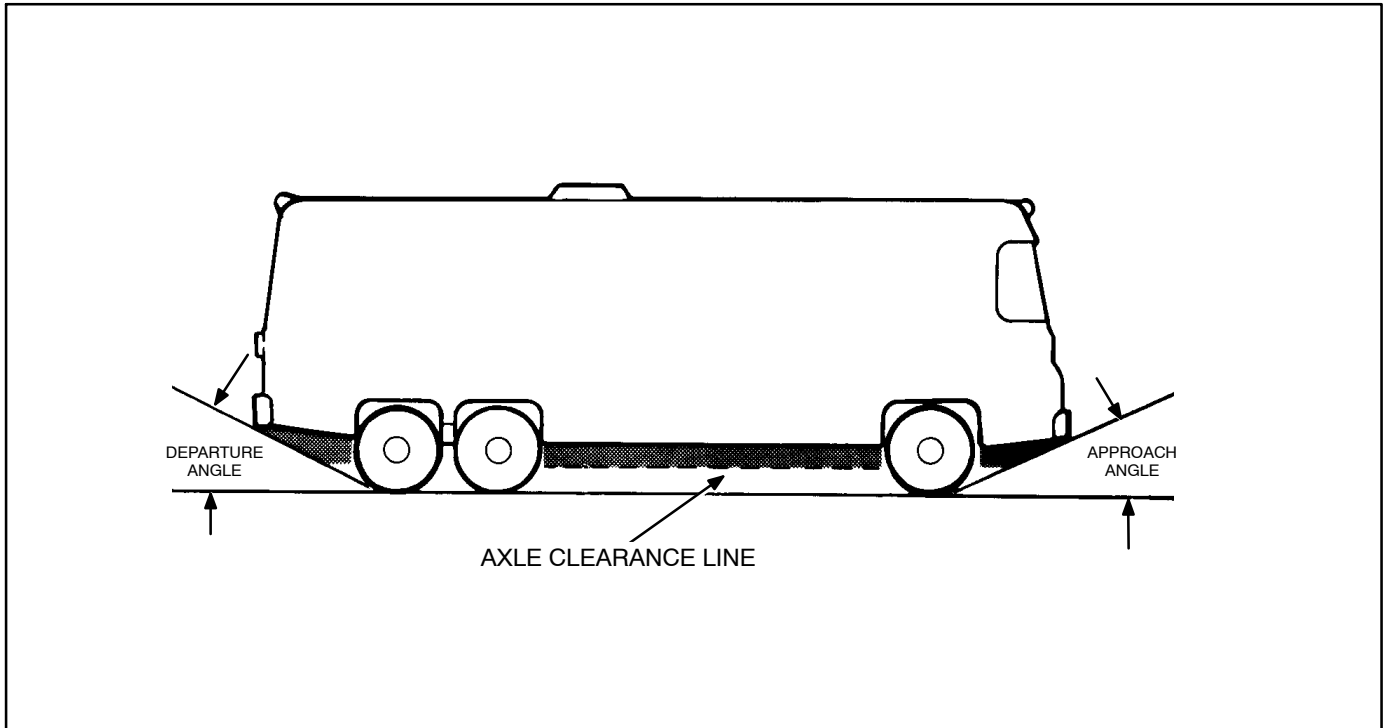

FIGURE 7. APPROACH AND DEPARTURE ANGLES AND AXLE CLEARANCE LINE

**THIS PAGE IS INTENDED TO BE BLANK**

# Fuel Connections

**⚠ WARNING** Diesel fuel is a combustible and can cause severe personal injury or death. Do not smoke or allow any flame, spark, pilot light, arc-producing equipment, electrical switch or other ignition source around fuel or fuel components, or in areas sharing ventilation. Keep a type multi-class fire extinguisher handy.

Do not interconnect generator set and vehicle engine fuel lines. Follow the vehicle chassis manufacturer's instructions when making connections to the vehicle engine fuel tank.

**⚠ CAUTION** Either or both engines could starve for fuel if the generator set and vehicle engine fuel lines are interconnected. Always use separate fuel lines or a separate fuel tank for the generator set.

To prevent the generator set from running the vehicle out of fuel, do not extend the generator set fuel pick-up tube down into the fuel tank as far as the pickup tube for the vehicle engine.

Fuel lines (supply and return) must have at least a 1/4 inch (6.4 mm) ID. See Figure 8 for connections at the generator set.

Run the fuel line at or above the top of the fuel tank to reduce the risk of siphoning fuel out of the tank if the line should break. The maximum fuel pump lift is 36 inches (1 meter).

Route fuel lines away from electrical wiring and hot engine exhaust components. Fuel lines should be accessible for inspection and replacement, protected from damage and secured to prevent kinking, contact with sharp edges and chafing due to vibration.

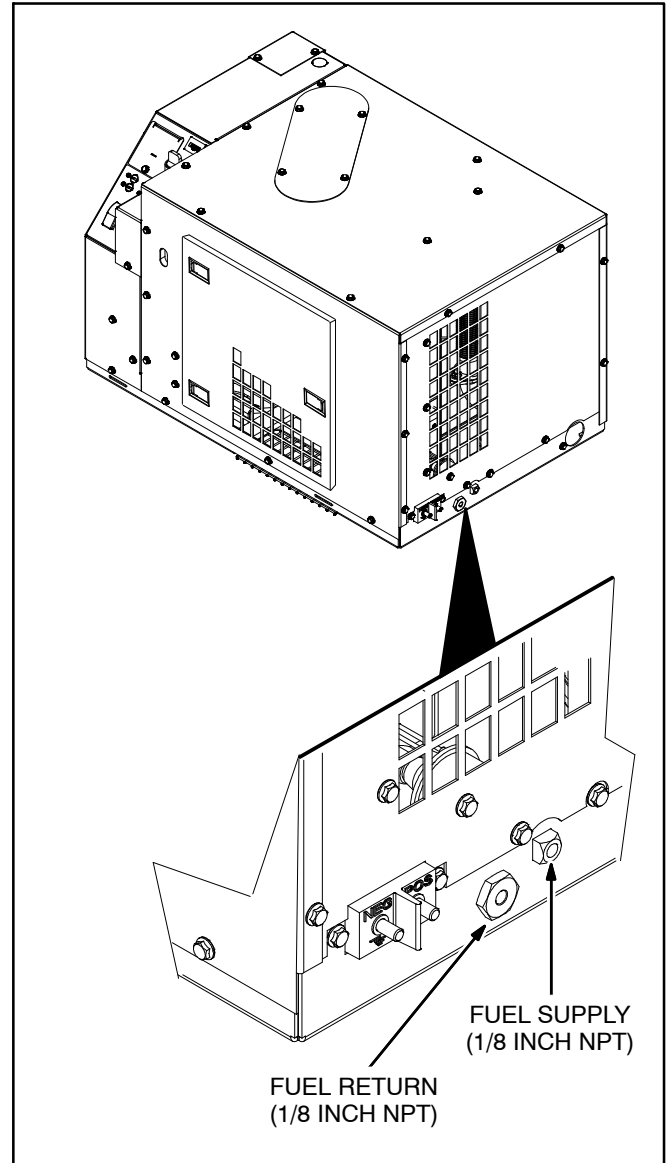

**FIGURE 8. FUEL CONNECTIONS**

## BIO-DIESEL FUELS B5 – B20

### Approved Bio-Diesel Fuel:

- Bio-diesel meeting either ASTM D6751 or EN14214.
- Fuel meeting either ASTM D6751 or EN14214 fuel can be blended with an acceptable diesel fuel meeting ASTM D975 meeting ASTM D975 up to 20 percent volume concentration (B20).

For bio-diesel blends above B5 and up to B20 the following installation requirements must be met:

- Supply and Return fuel lines and fittings must be bio-diesel compatible. Not all fuel hoses and fittings are bio-diesel compatible. All fuel wetted components must not contain the following materials: copper, brass, bronze, zinc, lead, tin, natural rubber and nitrile rubber compounds. Check with your manufacturer for bio-diesel compatibility.
- Fuel tanks must be made from the following materials: aluminum, steel, fluorinated polyethylene, fluorinated polypropylene or Teflon (PTFE).
- Verify the vehicle propulsion engine is capable of using B20 when sharing the same fuel tank with the generator set.
- A bio-diesel compatible fuel water separator is required. Cummins strongly recommends using Cummins Filtration filters equipped with StrataPore™ media. This filter media removes water more efficiently than standard cellulosic filter media, which will not provide adequate fuel water separation capabilities. However, even StrataPore™ fuel filter media is not as effective in removing water from bio-diesel as it is in removing water from petro diesel. Therefore, preventing water from entering the fuel supply (vehicle or storage) remains very important.

Place the fuel water separator in a location that is accessible for service by as close the generator set as possible. Locating the separator ahead of the generator set fuel pump is acceptable.

### Additional information:

- Bio-diesel blends have higher pour and cloud points than standard diesel fuels. generator set locations far from the fuel tank combined with low fuel flow rates can make the generator set fuel system very susceptible to fuel starvation related to gelling in cold weather (below 23°F/–5°C). In addition to electric or coolant tank heaters, consideration to routing and possible heating or insulation of the fuel lines to the generator set may be needed.
- Bio-Diesel blends can oxidize more quickly than standard diesel fuels; more frequent fuel filter service intervals may be required and shorter fuel storage life in tanks is likely.

**⚠WARNING** It is highly recommended that specific market applications are avoided or exercised with extra care due to some of the properties of bio-diesel fuel blends such as cold weather operation, long term storage, material incompatibilities and other effects on engine operating characteristics. Such applications that should use standard fuels include applications that will experience seasonal usage, storage for periods exceeding 60 days, and extreme temperatures or humidity.

### Storage requirements:

- If using bio-diesel for seasonal applications (stored more than 90 days), the generator set must be purged before storage by running the engine on pure diesel fuel meeting ASTM D975 for a minimum of 30 minutes.

**TABLE 2. CUMMINS BIO-DIESEL RECOMMENDATIONS**

<b>APPLICATION</b>	<b>RECOMMENDATION FOR BIO-DIESEL BLENDS</b>	<b>RECOMMENDATIONS</b>	<b>COMMENTS</b>
Emergency Standby RV Seasonal/Commercial with low annual hour accumulation	Not Recommended	Use petroleum diesel only.	Low fuel usage and critical start nature of Emergency Standby make bio-diesel impractical.
Limited Time Prime	Approved with Recommendations	Use fuel within 6 months of manufacture. Flush fuel system with petroleum diesel prior to storage.	Bio-diesel is suitable for constant high load operation with proper precautions.
Unlimited Time Prime	Approved with Recommendations	Use fuel within 6 months of manufacture. Flush fuel system with petroleum diesel prior to storage/transport.	Bio-diesel is suitable for variable load operation with proper precautions.
Continuous	Approved with Recommendations	Use fuel within 6 months of manufacture.	Bio-diesel is suitable for base load operation with proper precautions.

**THIS PAGE IS INTENDED TO BE BLANK**



# Electrical Connections

## AC POWER CONNECTIONS

**⚠️ WARNING HAZARDOUS VOLTAGE!** *Touching uninsulated live parts inside the generator set and connected equipment can result in severe personal injury or death. For your protection, stand on a dry wooden platform or rubber insulating mat, make sure your clothing, and shoes are dry, remove jewelry from your hands and use tools with insulated handles. Secure protective covers when completing installation.*

**⚠️ WARNING IMPROPER WIRING** *can cause fire or electric shock resulting in severe personal injury or death.*

**⚠️ WARNING Accidental starting of the generator set** *can cause severe personal injury or death. Do not connect the starting battery until so instructed in Installation Review and Startup.*

### Wiring Methods

The generator set is equipped with a terminal block and conduit connector knockouts for AC power output connections (Figure 9). See the generator set connection diagrams on Page 36.

AC wiring methods must be in accordance with the National Electrical Code or IEC 60364-7-708, as appropriate. Note especially the following:

**⚠️ WARNING EXHAUST GAS IS DEADLY!** *Seal all wiring openings into the vehicle interior to keep out exhaust gas.*

**⚠️ WARNING Routing AC wiring with fuel lines** *can lead to fire and severe personal injury or death. Keep AC wiring away from fuel lines.*

Have a trained and experienced electrician supervise and inspect the installation of all AC wiring.

Secure only one lead at each AC output terminal. The terminals are suitable for wire gauges up to No. 6 AWG (16 mm<sup>2</sup>). Torque the terminals to 13 in-lbs (1.5 N-m). When stranded conductors are used, it is recommended that copper ferrules, available for the various wire gauges, be crimped on the stripped ends of the conductors to facilitate terminal connections. Otherwise, the

terminals must be re-torqued after a few minutes because the connection can loosen if the individual strands spread out.

Use vibration-proof switches and controls to prevent the opening and closing of circuits while the vehicle is in motion.

Use rain-tight conduit, conduit connectors and junction boxes for all exterior wiring.

Provide ground fault circuit interrupters (GFCIs) or residual current devices (RCDs) for all convenience power receptacles.

Seal all conduit openings into the vehicle interior to keep out exhaust gas. Apply silicone rubber or equivalent sealant inside and outside each conduit connector. (Flexible conduit is not vapor-tight and will allow exhaust gas to enter along the wires if not sealed.)

Route or protect AC wiring so that it will not be cut or abraded, exposed to hot surfaces or damaged by road debris. Keep AC wiring away from fuel lines and control wiring (see Remote Control).

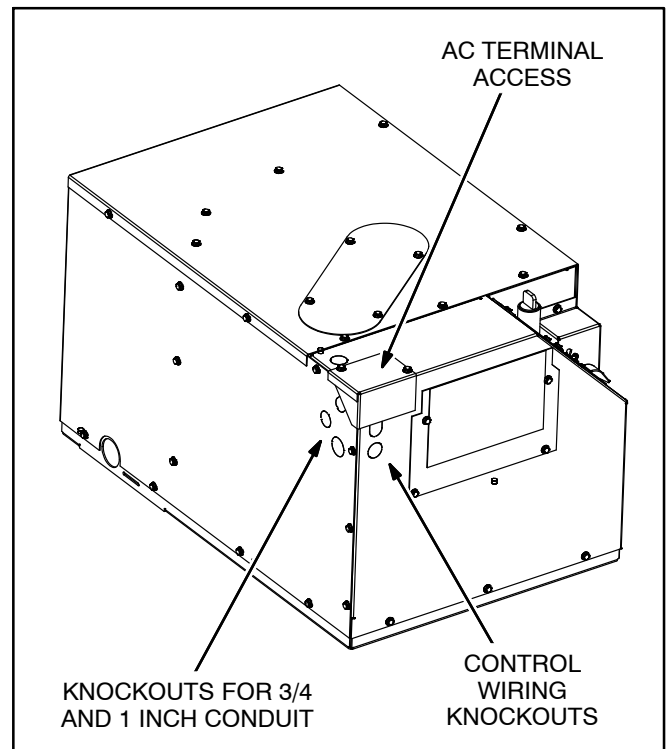

**FIGURE 9. ACCESS FOR AC OUTPUT AND REMOTE CONTROL CONNECTIONS**

## Grounding

**⚠WARNING** *Faulty grounding can lead to fire or electrocution and severe personal injury or death. Grounding must be in accordance with applicable codes.*

Connect grounding terminal TB1-5 (Page 36) in accordance with applicable codes.

**50 Hz Model HDKBB Only** – If the authority having jurisdiction requires an ungrounded 230 VAC system, it will be necessary to cut the internal grounding jumper (Figure 10). To do this, remove the side access cover (four screws) and cut the short jumper between the ground terminal screw and the terminal

screw on the red, hexagonal insulator. Cut the jumper as close to each terminal connector as possible to avoid having to loosen the connections for the other wires at the terminals.

## Vehicle Connections to Utility Power

**⚠WARNING** *Interconnecting the generator set and the public utility (or any other power source) can lead to electrocution of utility line workers, equipment damage and fire. Use an approved switching device to prevent interconnections.*

A vehicle with provisions for connecting utility power must have an approved device to keep the generator set and utility from being interconnected.

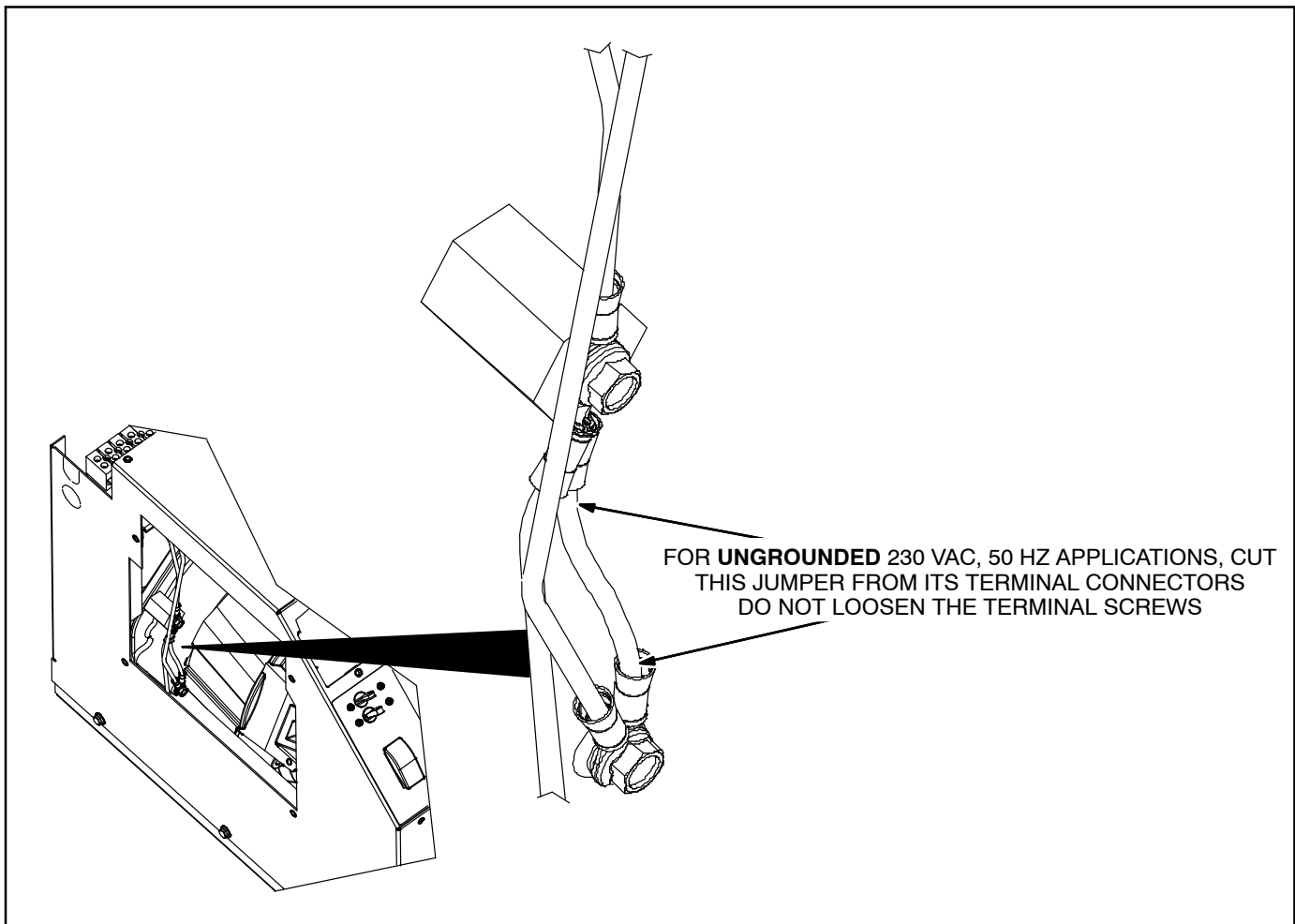

**FIGURE 10. MODEL HDKBB GROUNDING JUMPER**

## REMOTE CONTROL CONNECTIONS

Leads for connection to a remote control panel are terminated in a 10-pin sealed connector and are stowed inside the AC terminal enclosure when the generator set leaves the factory. Details of the connector and its mate are provided on the Outline Drawing (Figure 15). Refer to the Wiring Schematic (Figure 17) for pin connections.

### Remote Control Panels

Cummins offers harnesses of various lengths with mating receptacles and three remote control kits as follows:

- Remote switch / status lamp.
- Remote switch / status lamp and hour meter.
- Remote switch / status lamp and DC voltmeter.

If another source is used for the remote panel:

The control switch should be a two-pole, momentary-contact, center-return/center-off type of switch with an indicator light.

The total load connected to **P2-E** (Switched B+) should not exceed 2 amp.

The total load connected to **P2-F** (Status Light) should not exceed 2 amp.

### Wiring Methods

**⚠WARNING** **EXHAUST GAS IS DEADLY! Seal all wiring openings into the vehicle interior to keep out exhaust gas.**

Remove the AC terminal access cover and remove one of the control wiring knockouts.

Pull out the remote control connector plug, fit the bushing around the connector leads into the knockout slot and secure the access cover.

Snap the connector plug and harness receptacle together.

If the harness does not have a plug for connections at the control panel, use solder-type butt connectors and heat-shrink insulation tubing to connect to the wiring from the remote panel. Use in-

sulated 18 AWG (1 mm<sup>2</sup>) copper conductors for the wiring from the remote panel.

Keep control leads away from AC power leads to reduce the possibility of erratic operation due to induced signals.

Seal the hole where the leads enter the interior of the vehicle to keep out exhaust gas. Use silicone rubber or an equivalent type of sealant.

## BATTERY CONNECTIONS

**⚠WARNING** **Accidental starting of the generator set can cause severe personal injury or death. Do not connect the starting battery until so instructed in Installation Review and Startup. Make sure an automatic generator set starting system is disabled.**

### Battery Capacity

The generator set has a 12 VDC, negative-ground control and starting system. See *Specifications* for the requirements for cranking batteries.

### Battery Recharging

The generator set is equipped with a 10-amp, regulated-voltage battery charger.

### Battery Compartment

Batteries must be mounted in a separate compartment from that of the generator set and away from spark-producing equipment. An enclosed compartment must have openings of at least 1.7 square inches (11 square centimeters) at the top and bottom for ventilation of battery gasses. Batteries should be mounted such that spills and leaks will not drip acid on fuel lines, wiring and other equipment that could be damaged.

**⚠WARNING** **Arcing can ignite the explosive hydrogen gas given off by the battery, causing severe personal injury. The battery compartment must be ventilated and must isolate the battery from spark-producing equipment.**

## Battery Cables

Battery wiring methods must be in accordance with the National Electrical Code or IEC 60364-7-708, as appropriate.

Size battery cables according to Table 3. The current path between the generator set and the negative (-) battery terminal must also be able to carry full cranking current without causing excessive voltage drop. It is highly recommended that a full-length cable be used to connect the generator set to the negative (-) battery terminal (Figure 11). Note also that codes may require a bonding conductor between the generator set and vehicle frame and between the battery and vehicle frame.

If the vehicle frame is used as the path between the negative (-) battery terminal and the generator set (Figure 12), all frame members in the path of battery cranking currents must have substantial cross sections. The electrical resistance of riveted or bolted frame joints must also be carefully considered, especially if the joints will be exposed to corrosive conditions. A cable sized according to Table 3 must be used to connect the frame to the designated negative (-) terminal on the generator set (Figure 12). **The generator set mounting bolts are not considered adequate means for bonding the generator set to the vehicle frame, either for the purpose of carrying cranking currents or for complying with requirements for generator set/system grounding.**

**⚠WARNING** Routing battery cables with fuel lines can lead to fire and severe personal injury or death. Keep battery cables away from fuel lines.

Route battery cables away from fuel lines and hot engine exhaust components. Battery cables should be accessible for inspection and replacement, protected from damage and secured to prevent chafing due to vibration.

**TABLE 3. BATTERY CABLE SIZES FOR AMBIENT TEMPERATURES DOWN TO -20° F (-29° C)**

TOTAL CABLE LENGTH, FEET (METERS)	CABLE SIZE, AWG (mm <sup>2</sup> )
0 to 15 (0 to 4.5)	0* (50)
16 to 20 (4.5 to 6)	000 (95)

\* - A total length of up to 25 feet (7.6 meters) may be used in warmer climates or when battery capacity totals at least 1200 CCA (Cold Cranking Amps).

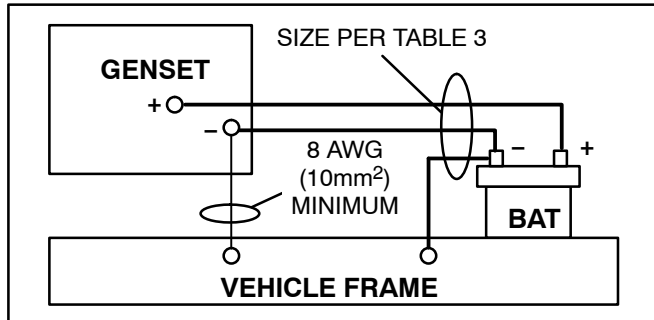

**FIGURE 11. FULL-LENGTH CABLE FROM BATTERY NEGATIVE (-) TERMINAL**

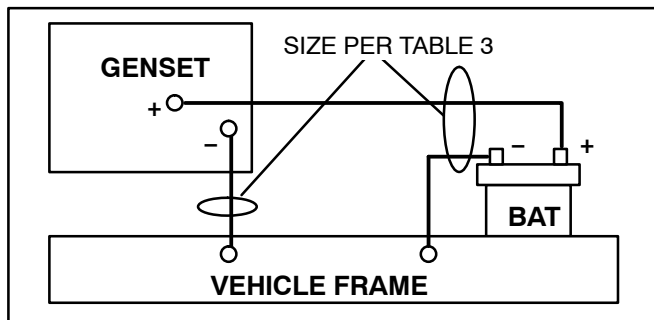

**FIGURE 12. VEHICLE FRAME AS PATH FROM BATTERY NEGATIVE (-) TERMINAL**

## Generator Set Bonding Terminal

The negative (-) battery cable terminal shown in Figure 13 is also the bonding terminal for grounding the generator set to the vehicle chassis. If the grounding cable is also going to carry starter motor current, it must be sized the same as the battery cables.

## Connecting Battery and Bonding Cables

Terminate the battery cables with ring terminals sized for the 5/16 inch generator set terminal screws (Figure 13). Permanently mark each end of each cable as to its polarity, positive (+) or negative (-). After making sure the battery cables are not connected at the battery and that an automatic generator set starting system is disabled, connect the battery and grounding cables to the generator set. Torque the terminals to 7.5 lb-ft (10 N-m).

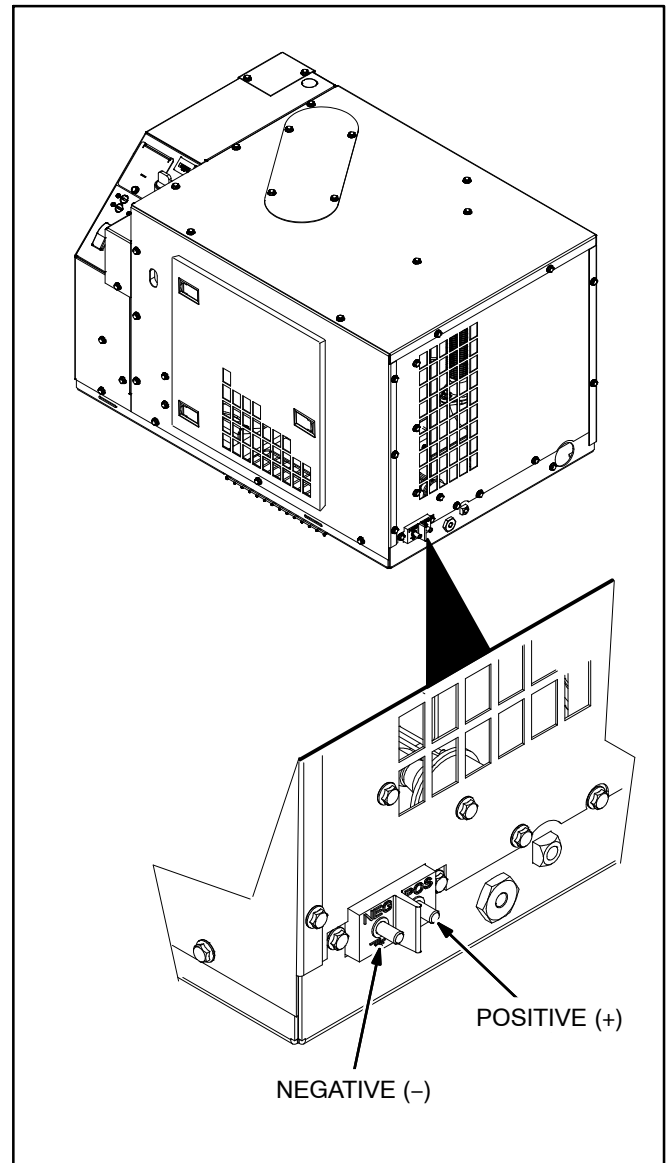

**FIGURE 13. BATTERY CABLE TERMINALS**

**THIS PAGE IS INTENDED TO BE BLANK**

# Installation Review and Startup

## HOT AIR RECIRCULATION TEST

A representative installation of the generator set must be tested to determine that the generator set will not overheat due to recirculation of hot air back into the generator set.

### Test Method

Complete a representative installation.

Conduct the test in a well ventilated space in which carbon monoxide cannot accumulate, but that is protected from cross drafts that could affect temperature measurements.

Connect a large, constant load to the generator set. If a load bank is available, connect at least 3/4 full load. If not, connect and run the largest combination of constant loads that can be kept on during the test without tripping the generator set circuit breaker. For example, run a combination of air conditioners and lights. Make sure air conditioners stay on and do not cycle during the test.

Measure temperatures with thermocouples not heavier than No. 24 AWG (0.21 mm<sup>2</sup>).

Measure generator set inlet air temperature with one thermocouple tied in the middle of the inlet air grille (Figure 14).

Measure ambient air temperature with a shielded thermocouple within 4 feet (1.2 meters) of the generator set and at approximately the same height. Make sure the thermocouple will not be

affected by warm air discharged from the generator set or by sunlight. Use 2 inch diameter white PVC piping at least 6 inches long as a thermocouple shield.

Close all generator set compartment doors and run the generator set for at least 90 minutes. Record temperatures at 15 minute intervals. See Table 4 for an example of how the data can be arranged for recording and analysis.

**TABLE 4. TEMPERATURE DATA**

THERMOCOUPLE LOCATION	TEMPERATURE C° (F°)				
	Time Of Reading				
AMBIENT AIR					
INLET AIR					

### Test Requirement

The rise in inlet air temperature over ambient air temperature must not exceed 15°F (8°C). A rise in inlet air temperature indicates hot air recirculation. If the rise exceeds the requirement, steps must be taken to reduce recirculation to an acceptable level. Review *Mounting, Location and Venting* (Page 11).

**CAUTION** *High ambient operating temperatures can reduce maximum generator set power if the air temperature rise in this test is on the high end of the acceptable range.*

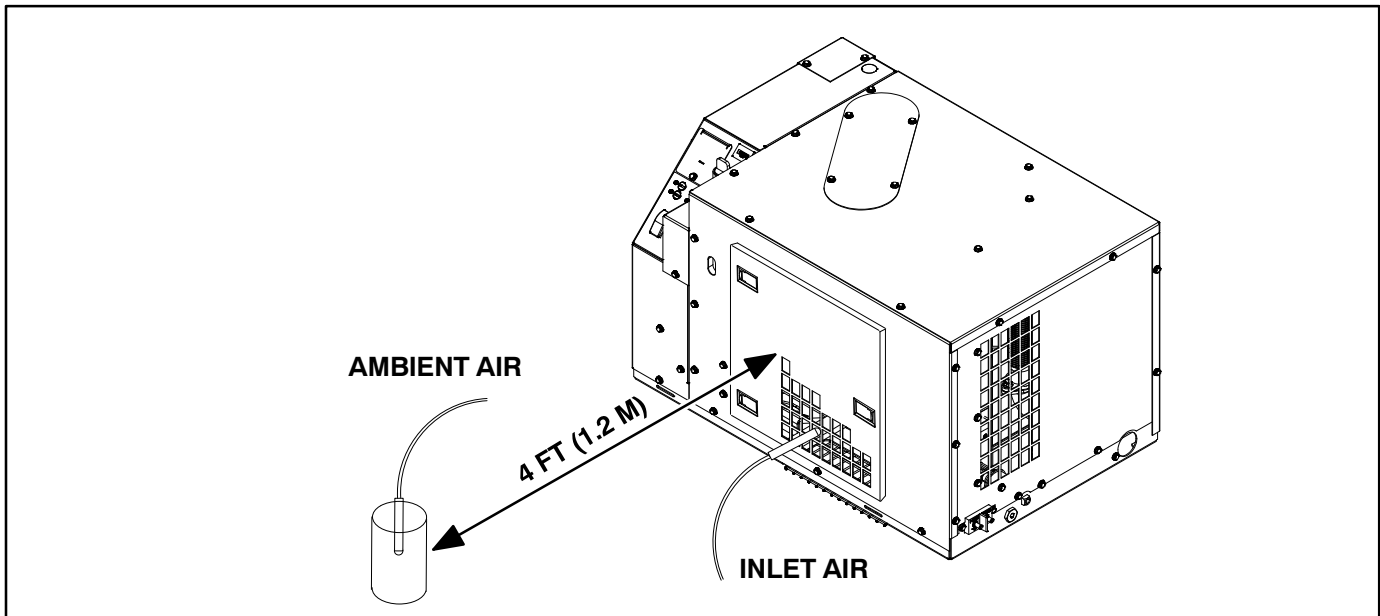

**FIGURE 14. THERMOCOUPLE LOCATIONS**

### INSTALLATION REVIEW

Before starting the generator set inspect the installation and check off (✓) each of the following questions if it can be answered "YES". If a question cannot be checked off, review the appropriate section in the manual.

- Is the operator's console easily accessible for starting and stopping the generator set, resetting circuit breakers and checking and adding engine coolant?
- Is the generator set securely bolted in place?
- Is there clearance all around the generator set?
- Are the cooling and combustion air inlet and outlet openings free of obstructions?
- Is there easy access for draining the engine oil?
- Is there easy access for draining the engine coolant?
- Is there easy access for changing the air filter, checking oil level and adding oil?
- Is there easy access for cleaning out the spark-arrest muffler?
- Are all tailpipe connections tight and all hangers and support straps secure?
- Does the tailpipe terminate at least 1 inch (25 mm) beyond the perimeter of the vehicle and at least 6 inches (153 mm) away from any opening into the vehicle?
- Is the tailpipe routed such that it is not likely to be struck while the vehicle is moving?
- Is the generator set located outside the interior space of the vehicle and separated by approved vapor-tight and fire-resistive materials?
- Are all wiring holes into the vehicle interior (inside and outside conduit connectors) sealed to keep out exhaust gas?
- Have the AC output connections been made properly.
- Have properly sized batteries and battery cables been installed?
- Have the battery cables been secured at sufficient intervals to prevent chaffing and contact with sharp edges, fuel lines and hot exhaust parts?
- Is the generator set bonding terminal (negative [-] battery cable terminal) properly grounded to the vehicle chassis?
- Are all fuel connections tight?
- Have the fuel lines been secured at sufficient intervals to prevent chaffing and contact with sharp edges, electrical wiring and hot exhaust parts?
- Is the generator set protected from direct road splash, rain and snow?
- Does the generator set clear the ground by at least 12 inches (305 mm)?
- Has the HOT AIR RECIRCULATION TEST been conducted? Are the results acceptable?



## STARTUP

When all installation requirements have been met, connect the battery cables to the battery, positive (+) cable first.

**⚠WARNING** *Arcing at battery terminals or in light switches or other equipment, and flames or sparks, can ignite battery gas causing severe personal injury. To prevent injury:*

- *Ventilate battery area before working on or near battery*
- *Wear safety glasses*
- *Do not smoke*
- *Switch work light ON or OFF away from battery*
- *Stop generator set and disconnect charger before disconnecting battery cables*
- *Disconnect negative (-) cable first and reconnect it last.*

Read through the Operator Manual and perform the maintenance and pre-start checks instructed. The generator set is shipped from the factory with proper levels of engine oil and coolant, which should nevertheless be checked before the generator set is started. Start and operate the generator set, following all the instructions and precautions in the Operator Manual.

**⚠WARNING** *EXHAUST GAS IS DEADLY! Do not operate the generator set when the vehicle is indoors unless there is ample fresh air ventilation.*

Check for fuel, coolant and exhaust leaks and unusual noises while the generator set is running under full and intermediate loads. To calculate electrical loads see POWERING EQUIPMENT in the Operator Manual. Do not place the generator set in service until all leaks have been fixed and operation is satisfactory.

**THIS PAGE IS INTENDED TO BE BLANK**

# Specifications

	HDKBB	HDKBC
<b>GENERATOR SET CONTROLLER:</b> Integrated Microprocessor Based Engine and generator set Controller		
<b>GENERATOR SET:</b> Two-Bearing, Two-Pole Rotating Field, "Poly-Vee" Belt Drive		
Power (@1.0 PF)	4800 W	5000 W
RPM	3000	3600
Frequency	50 Hz	60 Hz
Voltage	230V 1-Ph	120V 1-Ph, 120/240V 1-Ph, or 120/240V 3-Ph
Current	21 A	41.7/20.8 A or 12 A (3-Ph)
Circuit Breakers	2-pole 25 A (1 pole used)	2-pole 25 A (1-Ph) or 3-pole 15 A (3-Ph)
<b>FUEL CONSUMPTION:</b>		
No-load	0.20 gph (0.74 lph)	0.25 gph (0.95 lph)
Half-load	0.32 gph (1.23 lph)	0.39 gph (1.47 lph)
Full-load	0.54 gph (2.04 lph)	0.60 gph (2.27 lph)
<b>ENGINE:</b> 2-Cylinder In-Line, Water-Cooled, Indirect-Injection, 4-Stroke Cycle Diesel		
RPM	2880	2880
Bore	2.64 in (67 mm)	2.64 in (67 mm)
Stroke	2.68 in (68 mm)	2.68 in (68 mm)
Displacement	29.23 in <sup>3</sup> (479 cc)	29.23 in <sup>3</sup> (479 cc)
Compression Ratio	23 : 1	23 : 1
Injection Order	1-2	1-2
Engine Timing	18.25° to 19.75° BTDC	18.25° to 19.75° BTDC
Fuel Nozzle Injection Pressure	1991 psi (13.73 mPa)	1991 psi (13.73 mPa)
Valve Lash: Intake & Exhaust (cold)	0.0057 – 0.0073 inch (0.145 – 0.185 mm)	0.0057 – 0.0073 inch (0.145 – 0.185 mm)
Oil Capacity (with filter)	2 quart (1.9 liter)	2 quart (1.9 liter)
Cooling System Capacity	3.0 quart (2.8 liter)	3.0 quart (2.8 liter)
<b>DC SYSTEM:</b>		
Nominal Battery Voltage	12 volts	12 volts
Minimum Battery Capacity CCA (Cold Cranking Amps)	475 amps down to 0°F (-17°C) 650 amps down to -20°F (-29°C)	475 amps down to 0°F (-17°C) 650 amps down to -20°F (-29°C)
Fuse F1 (control, start and glow plug circuits)	30 amp mini-bayonet	30 amp mini-bayonet
<b>WEIGHT:</b> 400 lbs (181 kg)		
<b>SIZE (L x W x H):</b> 34.5 x 22.9 x 20.3 in (876 x 581.2 x 514.4 mm)		
<b>SOUND LEVEL:</b> 68 dB(A) @ 10 ft (3m) before installation and @ 1/2-load		

**THIS PAGE IS INTENDED TO BE BLANK**

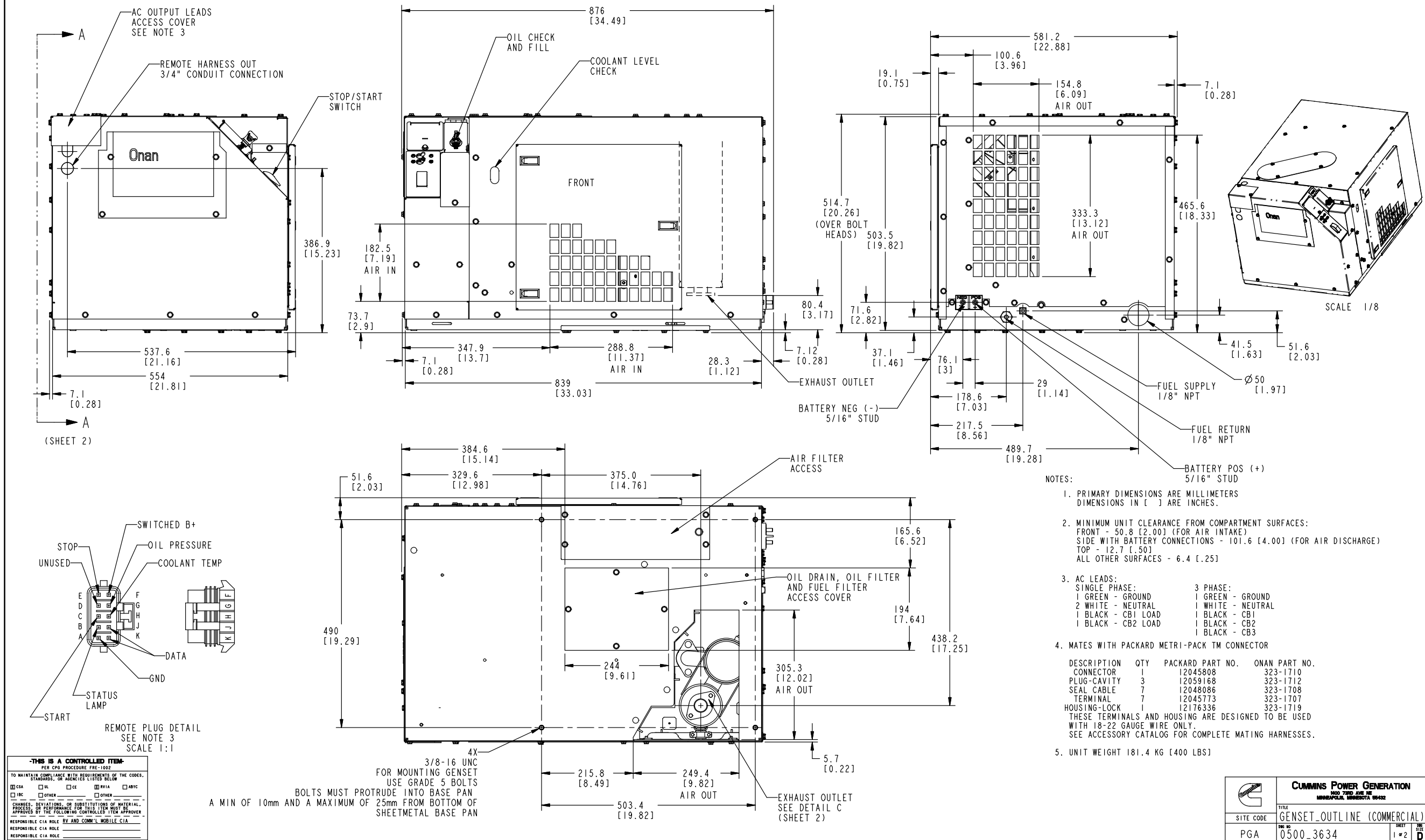
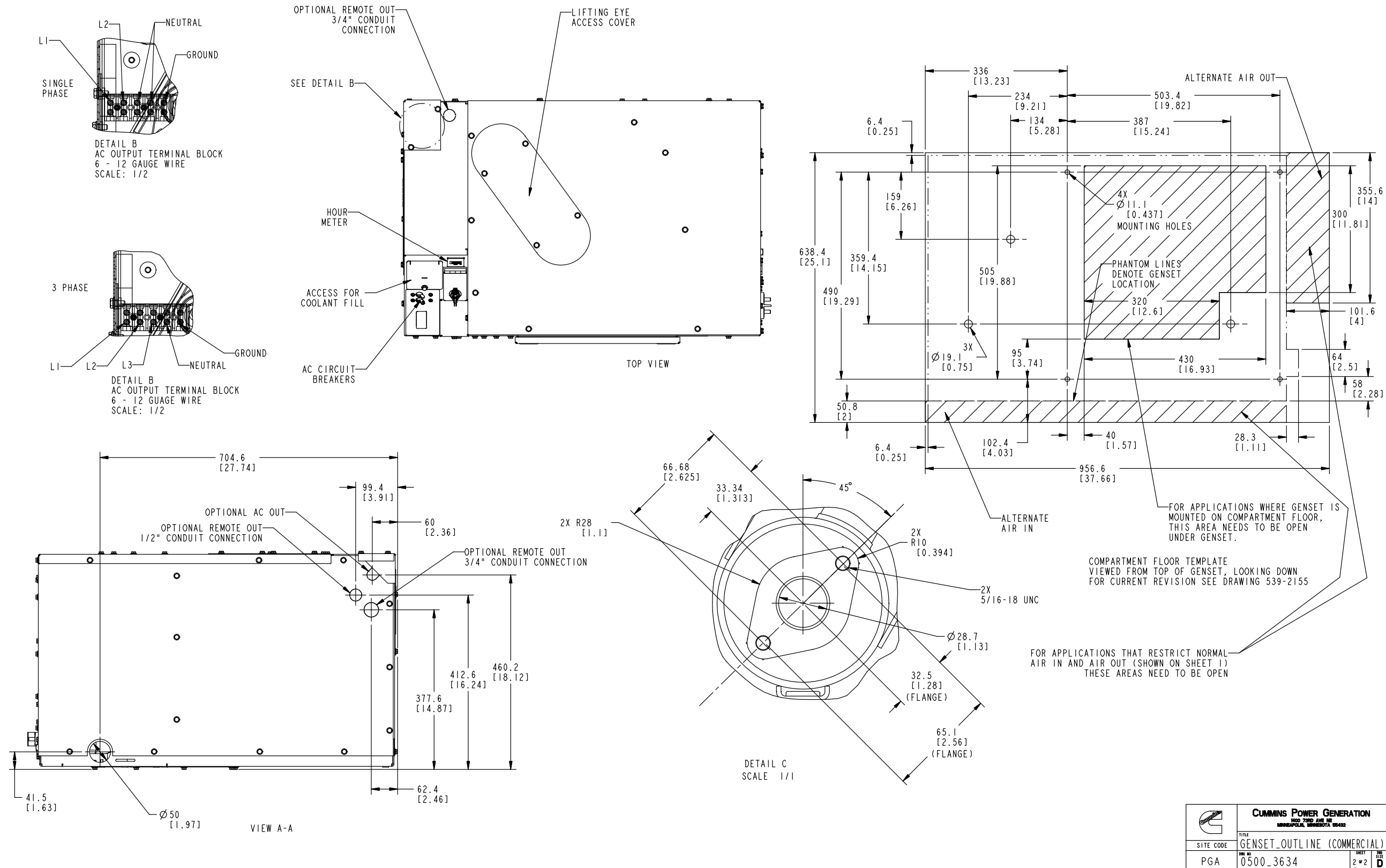

FIGURE 15. OUTLINE DRAWING—SHEET 1



	<b>CUMMINS POWER GENERATION</b> <small>1400 7TH AVE NE                  MINNEAPOLIS, MINNESOTA 55412</small>		
	SITE CODE	TITLE <b>GENSET_OUTLINE (COMMERCIAL)</b>	
	PGA	PPN NO 0500_3634	SHEET 2 of 2 TITLE D

FIGURE 16. OUTLINE DRAWING—SHEET 2

Drawing Name: 0630-2298 Revision: H

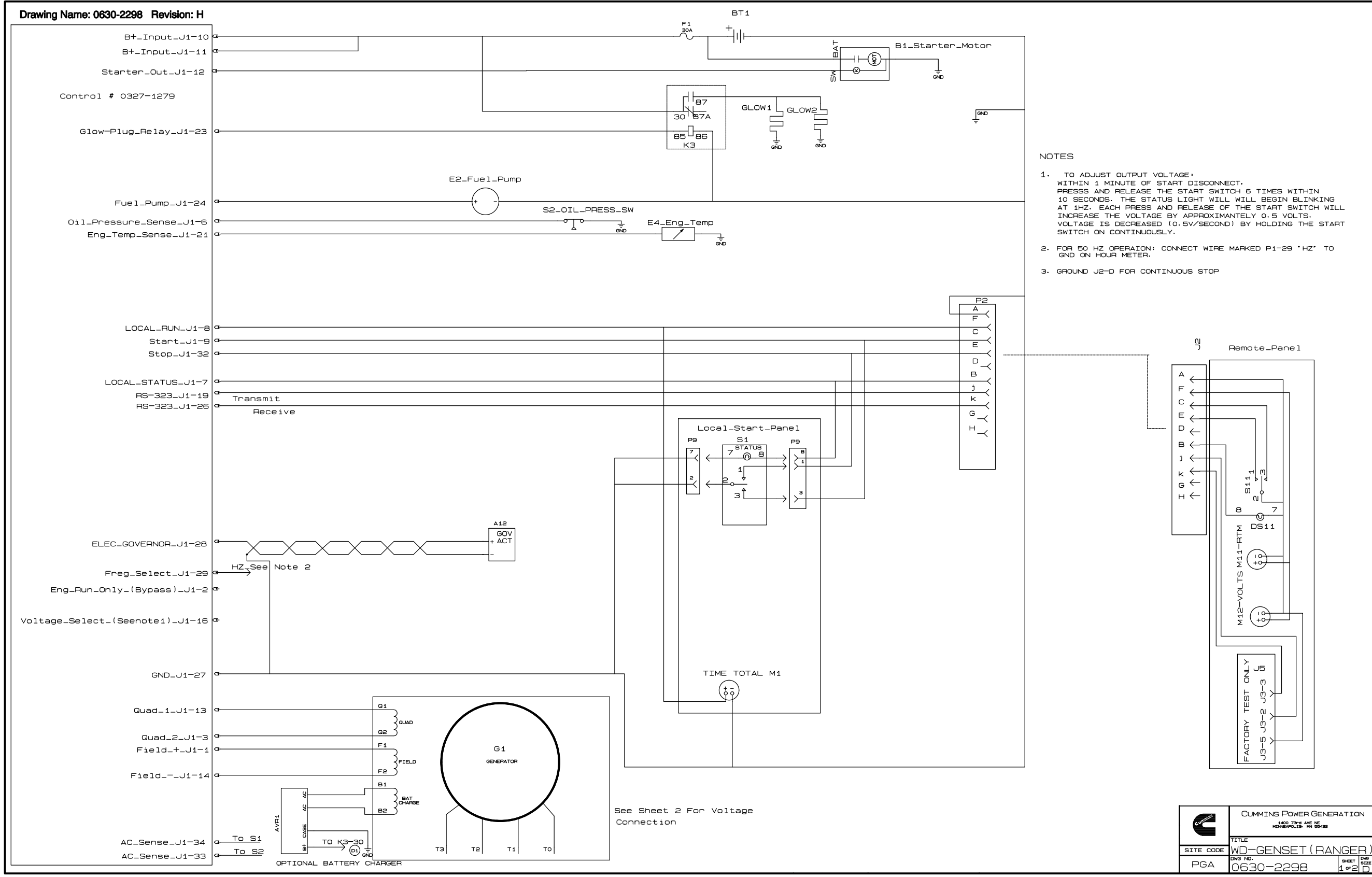

NOTES

1. TO ADJUST OUTPUT VOLTAGE: WITHIN 1 MINUTE OF START DISCONNECT, PRESS AND RELEASE THE START SWITCH 6 TIMES WITHIN 10 SECONDS. THE STATUS LIGHT WILL BEGIN BLINKING AT 1HZ. EACH PRESS AND RELEASE OF THE START SWITCH WILL INCREASE THE VOLTAGE BY APPROXIMATELY 0.5 VOLTS. VOLTAGE IS DECREASED (0.5V/SECOND) BY HOLDING THE START SWITCH ON CONTINUOUSLY.
2. FOR 50 HZ OPERAION: CONNECT WIRE MARKED P1-29 'HZ' TO GND ON HOUR METER.
3. GROUND J2-D FOR CONTINUOUS STOP

See Sheet 2 For Voltage Connection

OPTIONAL BATTERY CHARGER

		CUMMINS POWER GENERATION <small>1400 27th AVE SE                  HONOLULU, HI 96832</small>	
TITLE WD-GENSET (RANGER)		SITE CODE PGA	
DWG NO. 0630-2298		SHEET NO. 1 of 2	

FIGURE 17. WIRING DIAGRAM—SHEET 1

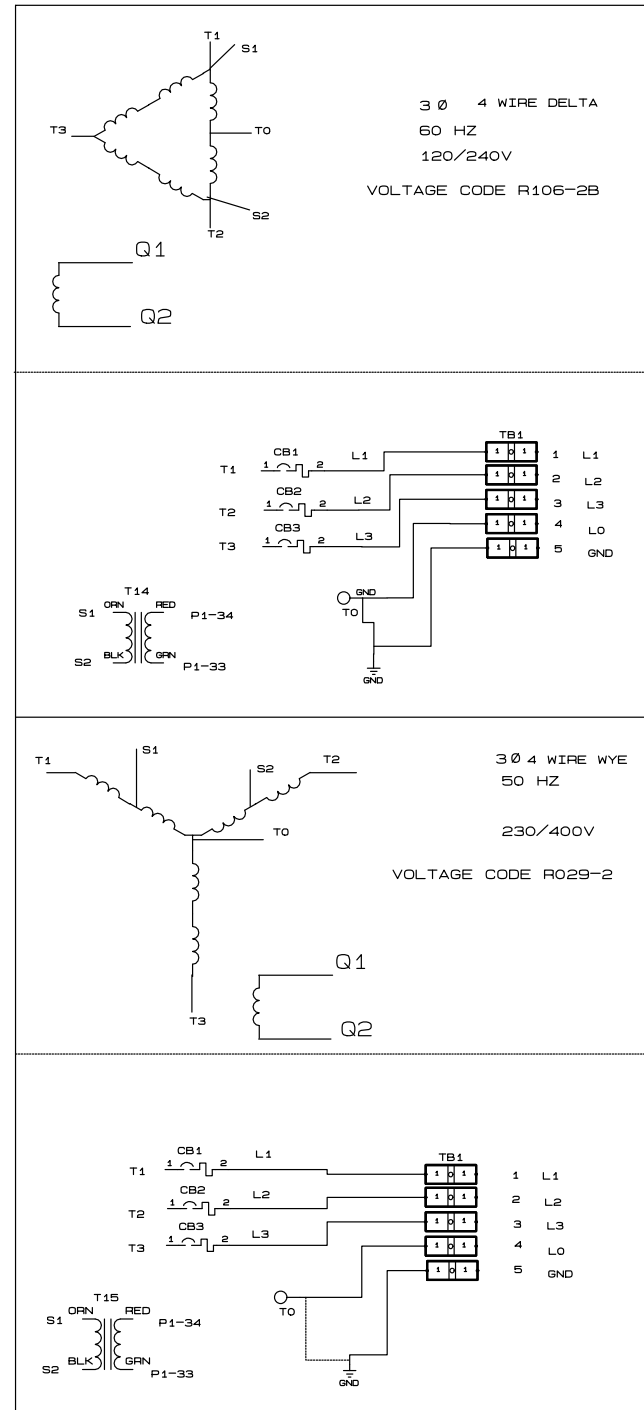

3Ø Generator Reconnection

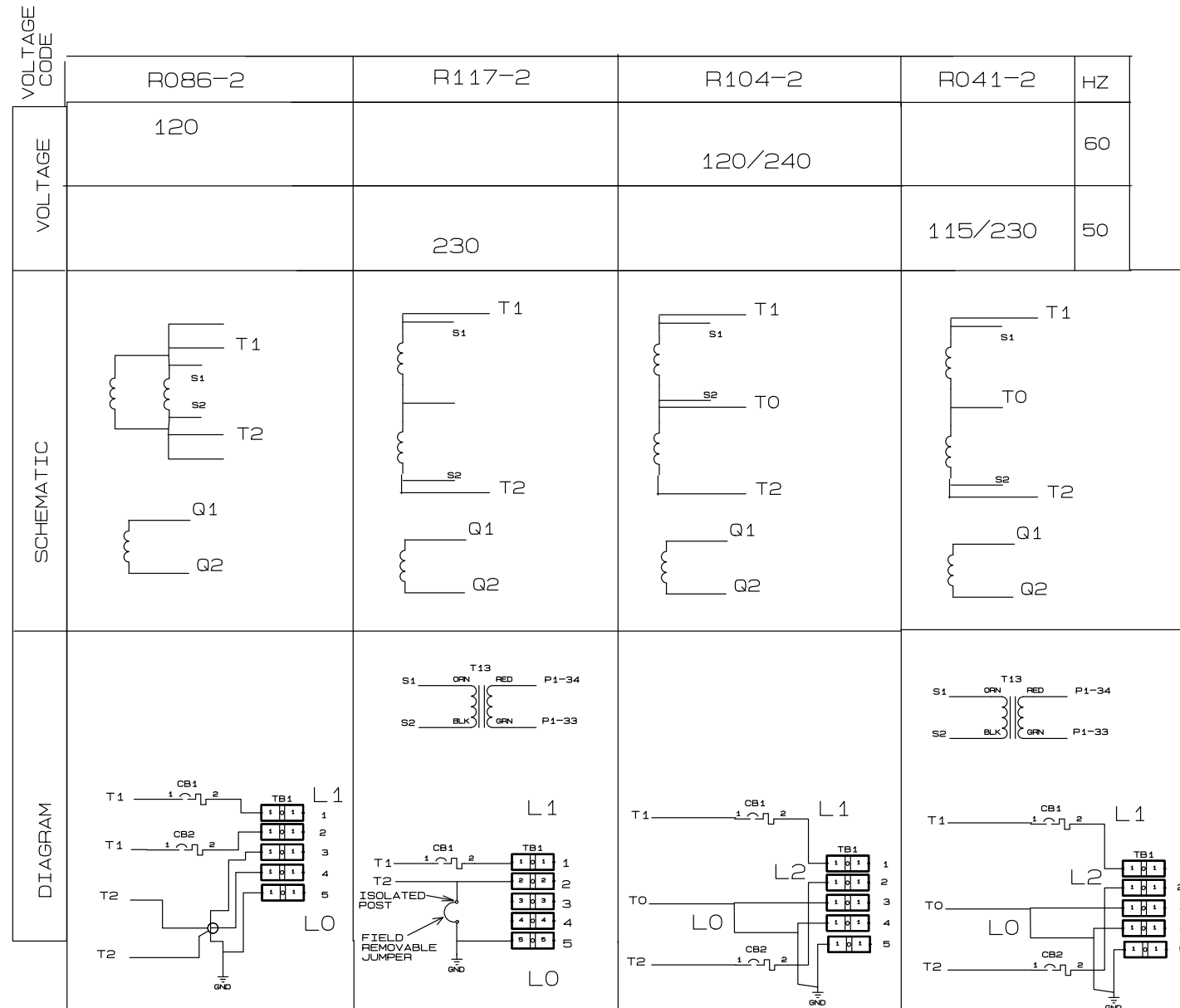

1Ø Generator Reconnection

	CUMMINS POWER GENERATION	
	1400 7th Ave SE Murfreesboro, TN 37132	
SITE CODE	TITLE	
PGA	WD-GENSET (RANGER)	
	DWG NO.	SHEET
	0630-2298	2 of 2

FIGURE 18. WIRING DIAGRAM—SHEET 2





[power.cummins.com](http://power.cummins.com)

Copyright © 2018 Cummins Inc. All rights reserved.

Cummins, Onan, and the "C" logo are registered trademarks of Cummins Inc. and its subsidiaries.

Other company, product, or service names may be trademarks or service marks of others.

Specifications are subject to change without notice.

