



Operator Manual

Onan Generator Set for Commercial Mobile

HDKAT (Spec A-T)

HDKAU (Spec A-T)

HDKAV (Spec A-T)

CALIFORNIA
Proposition 65 Warning

Diesel engine exhaust and some of its constituents are known to the State of California to cause cancer, birth defects, and other reproductive harm.

Table of Contents

1. IMPORTANT SAFETY INSTRUCTIONS	1
1.1 Overview	1
1.2 Warning, Caution, and Note Styles Used in This Manual	1
1.3 General Safety Precautions	1
1.4 Automatic Generator Start Control Hazards	3
1.5 Electrical Shock and Arc Flash Can Cause Severe Personal Injury or Death	3
1.6 Generator Voltage Is Deadly	4
1.7 Engine Exhaust/Carbon Monoxide Is Deadly	4
1.8 Diesel Fuel Is Combustible	5
1.9 Battery Gas Is Explosive	5
1.10 Moving Parts Can Cause Severe Personal Injury or Death	6
1.11 CARB	6
1.12 Generator Set Warning Labels	6
2. INTRODUCTION	9
2.1 About this Manual	9
2.2 Related Literature	9
2.3 Model Identification	10
2.3.1 Nameplate Location	10
2.4 How to Obtain Service	11
2.4.1 In U.S. and Canada	11
2.4.2 Outside U.S. and Canada	11
2.4.3 Information To Have Available	11
3. OVERVIEW	13
3.1 Electromagnetic Compatibility Compliance	13
3.2 Information for Generator Set Users	13
3.3 Build Standards	13
3.4 Specifications	15
3.4.1 Diesel Model Specifications	15
3.5 List of Acronyms	16
4. OPERATION	19
4.1 Key Component Locations	19
4.2 Control Panel	21
4.2.1 Generator Set Control Panel	21
4.2.2 Remote Control Panel	21
4.3 Starting and Stopping the Generator Set	23
4.3.1 Pre-start Checks	23
4.3.2 Priming the Fuel System	23
4.3.3 Starting the Generator Set	24
4.3.4 Stopping the Generator Set	24
4.4 Loading the Generator Set	24

4.4.1 Power Versus Altitude.....	26
4.5 Exercising the Generator Set.....	26
4.6 Resetting Line Circuit Breakers.....	27
4.7 Connecting Shore Power.....	28
4.8 Operating in Weather Extremes.....	28
4.9 Operating in Dusty Environments.....	28
4.10 Care of New or Rebuilt Engine.....	28
5. MAINTENANCE.....	29
5.1 Periodic Maintenance.....	29
5.1.1 Periodic Maintenance Schedule.....	29
5.2 Consumable Parts.....	30
5.3 General Inspection.....	30
5.4 Maintaining the Battery.....	30
5.5 Maintaining the Lubrication System.....	31
5.5.1 Oil Level.....	31
5.5.2 Engine Oil Recommendations.....	32
5.5.3 Changing Engine Oil and Oil Filter.....	33
5.6 Maintaining the Fuel System.....	34
5.6.1 Fuel System.....	34
5.6.2 Fuel Recommendations.....	35
5.6.3 Replacing the Fuel Filter.....	36
5.7 Maintaining the Cooling System.....	38
5.7.1 Cooling System.....	38
5.7.2 Coolant Level.....	39
5.7.3 Coolant Recommendations.....	39
5.7.4 Draining and Cleaning Cooling System.....	39
5.7.5 Refilling Cooling System.....	40
5.8 Exhaust System.....	40
5.9 Mechanical System.....	41
5.10 Service Door.....	41
5.11 Water Pump Belt Removal.....	42
5.12 Water Pump Belt Installation.....	42
5.13 Replacing the Air Filter Element.....	42
5.14 Cleaning the Spark Arrester.....	43
5.15 Storing the Generator Set.....	44
5.16 Returning the Generator Set to Service.....	45
6. TROUBLESHOOTING.....	47
6.1 Overview.....	47
6.2 Fault Codes.....	47
6.2.1 Code 1 - Engine Over Temperature.....	48
6.2.2 Code 2 - Low Oil Pressure.....	48
6.2.3 Code 3 - Service Check.....	48
6.2.4 Code 4 - Over Crank.....	49
6.2.5 Code 12 - Over Voltage.....	49
6.2.6 Code 13 - Under Voltage.....	49

6.2.7 Code 14 - Over Frequency	49
6.2.8 Code 15 - Under Frequency	50
6.2.9 Code 19 - Governor Actuator.....	50
6.2.10 Code 22 - Governor Actuator Overload	50
6.2.11 Code 27 - Voltage Sense.....	50
6.2.12 Code 29 - High Battery Voltage	50
6.2.13 Code 32 - Low Cranking Speed.....	50
6.2.14 Code 35 - Control Card Failure.....	51
6.2.15 Code 36 - Engine Stopped	51
6.2.16 Code 38 - Over Current (Field Overload)	51
6.2.17 Code 41 - Generator Rotor	52
6.2.18 Code 42 - Processor	52
6.2.19 Code 43 - Processor	52
6.2.20 Code 45 - Speed Sense	52
6.2.21 Code 48 - Generator Field Sense.....	52
6.2.22 Code 57 - Over Prime.....	52
6.3 Symptom Based.....	52
6.3.1 Status Indicator Not Working	52
6.3.2 Starting Batteries Run Down.....	53
6.3.3 Starter Engages-Disengages.....	53
6.3.4 No Power—Generator Set Running, Status Light On.....	53
7. MAINTENANCE RECORD.....	55

This page is intentionally blank.

1 Important Safety Instructions

1.1 Overview

Thoroughly read the Operator Manual before operating the generator set. It contains important instructions that should be followed during operation and maintenance. Safe operation and top performance can only be achieved when equipment is properly operated and maintained. The owners and operators of the generator set are solely responsible for its safe operation.

Generator set operation, maintenance, and installation must comply with all applicable local, state, and federal codes and regulations. Electricity, fuel, exhaust, moving parts, and batteries present hazards which can result in severe personal injury or death. Only trained and experienced personnel with knowledge of fuels, electricity, and machinery hazards should perform generator set installation or adjustment procedures; or remove, dismantle, or dispose of the generator set.

1.2 Warning, Caution, and Note Styles Used in This Manual

The following safety styles and symbols found throughout this manual indicate potentially hazardous conditions to the operator, service personnel, or equipment.

 DANGER
<i>Indicates a hazardous situation that, if not avoided, will result in death or serious injury.</i>

 WARNING
<i>Indicates a hazardous situation that, if not avoided, could result in death or serious injury.</i>

 CAUTION
<i>Indicates a hazardous situation that, if not avoided, could result in minor or moderate injury.</i>

NOTICE
Indicates information considered important, but not hazard-related (e.g., messages relating to property damage).

1.3 General Safety Precautions

 WARNING
<i>Operation of equipment is unsafe when mentally or physically fatigued. Do not operate equipment in this condition, or after consuming any alcohol or drug.</i>

⚠ WARNING

Maintaining or installing a generator set can cause severe personal injury. Wear personal protective equipment such as safety glasses, protective gloves, hard hats, steel-toed boots, and protective clothing when working on equipment.

⚠ WARNING

Running the generator set without the cover or service door can cause severe personal injury or equipment damage. Do not operate the generator set with the cover or service doors removed.

⚠ WARNING

Coolants under pressure can cause severe scalding. Do not open a radiator or heat exchanger pressure cap while the engine is running. Let the engine cool down before removing the coolant pressure cap. Turn the cap slowly and do not open it fully until the pressure has been relieved.

⚠ WARNING

Hot metal parts can cause severe burns, Avoid contact with the radiator, turbo charger, and exhaust system.

⚠ WARNING

Starting fluids, such as ether, can cause explosion and generator set engine damage. Do not use.

⚠ WARNING

Ethylene glycol, used as engine coolant, is toxic to humans and animals. Clean up coolant spills and dispose of used antifreeze in accordance with local environmental regulations.

⚠ WARNING

Used engine oils have been identified by some state and federal agencies to cause cancer or reproductive toxicity. Do not ingest, breathe the fumes, or contact used oil when checking or changing engine oil.

⚠ CAUTION

To prevent accidental or remote starting while working on the generator set, disconnect the negative (-) battery cable at the battery using an insulated wrench.

⚠ CAUTION

Unsecured or loose fasteners can cause equipment damage. Make sure all fasteners are secure and properly torqued.

⚠ CAUTION

Oily rags and other material can cause fire and restrict cooling. Keep the generator set, drip pan, and compartment clean.

⚠ CAUTION

Accumulated grease and oil can cause overheating and engine damage presenting a potential fire hazard. Keep the generator set clean and repair any oil leaks promptly.

NOTICE

Keep multi-class ABC fire extinguishers handy. Class A fires involve ordinary combustible materials such as wood and cloth. Class B fires involve combustible and flammable liquid fuels and gaseous fuels. Class C fires involve live electrical equipment. (Refer to NFPA No. 10 in applicable region.)

1.4 Automatic Generator Start Control Hazards

⚠ WARNING

Accidental starting can cause severe personal injury or death. Turn off the AGS whenever performing maintenance or service, when the vehicle is stored between uses, is awaiting service, or is parked in a garage or other confined area.

Unexpected starting may occur if the generator set is equipped with an inverter-charger or other Automatic Generator Start (AGS) control. This may cause exposure to:

- Unexpected generator starting
- Moving parts hazards
- Electric shock
- Exhaust carbon monoxide (CO)

1.5 Electrical Shock and Arc Flash Can Cause Severe Personal Injury or Death

⚠ WARNING

Electrical shocks and arc flashes can cause severe personal injury or death. Adhere to the following guidelines:

- *Only qualified service personnel certified and authorized to work on power circuits should work on exposed energized power circuits.*
- *All relevant service material must be available for any electrical work performed by certified service personnel.*
- *Exposure to energized power circuits with potentials of 50 VAC or 75 VDC or higher poses a significant risk of electrical shock and electrical arc flash.*
- *Refer to standard NFPA 70E, or equivalent safety standards in corresponding regions, for details of the dangers involved and for safety requirements.*

1.6 Generator Voltage Is Deadly

WARNING

Improperly connected generator electrical output connections can cause equipment damage, severe personal injury, or death. Electrical connections must be made by a trained and experienced electrician in accordance with applicable codes.

WARNING

Improper installations can cause equipment damage, severe personal injury, or death. All installations must be conducted by trained and experienced personnel in accordance with the installation instructions and all applicable codes.

WARNING

Back feed to shore power can cause electrocution and damage to equipment. The generator set must not be connected to shore power or to any other source of electrical power. An approved switching device must be used to prevent interconnections.

WARNING

Live electrical equipment can cause electrocution. Use caution when working on live electrical equipment. Remove jewelry, make sure clothing and shoes are dry, stand on a dry wooden platform or rubber insulating mat, and use tools with insulated handles.

1.7 Engine Exhaust/Carbon Monoxide Is Deadly

WARNING

Substances in exhaust gases have been identified by some state and federal agencies to cause cancer or reproductive toxicity. Do not breathe in or come into contact with exhaust gases.

WARNING

Carbon monoxide is a poisonous gas. Inhalation of this gas can cause severe personal injury or death. Adhere to the following bullet points to make sure carbon monoxide is not being inhaled by occupants of the vehicle as well as others working on or around the generator set.

- *Inspect for exhaust leaks, and test and confirm that all carbon monoxide detectors are working in accordance with the manufacturer's instructions or owner's manual, prior to every startup, and after every 8 hours of running.*
- *Never occupy the vehicle while the generator set is running unless the vehicle is equipped with a working carbon monoxide detector.*
- *Never operate the generator set when the vehicle is in a confined space, such as a garage, basement, or building of any kind.*
- *Make sure the exhaust system is installed in accordance with the generator set installation manual.*
- *Never use engine cooling air for heating a working or living space compartment.*

Carbon Monoxide (CO) is odorless, colorless, tasteless, and non-irritating. It cannot be seen or smelled. Exposure, even to low levels of CO for a prolonged period can lead to asphyxiation (lack of oxygen).

Mild effects of CO poisoning include:

- headache
- dizziness
- drowsiness
- fatigue
- chest pain
- confusion

More extreme symptoms include:

- vomiting
- seizure
- loss of consciousness

1.8 Diesel Fuel Is Combustible

WARNING

Diesel fuel is highly combustible. Adhere to the following bullets to avoid igniting fuel and fuel vapors.

- *Do not smoke or turn electrical switches on or off where fuel fumes are present or in areas sharing ventilation with fuel tanks or equipment.*
- *Keep flame, sparks, pilot lights, arc-producing equipment and all other sources of ignition well away from fuel lines and sources.*
- *Fuel lines must be secured, free of leaks, and separated or shielded from electrical wiring.*

WARNING

Flammable vapor can cause a diesel engine to over speed and become difficult to stop, resulting in possible fire or explosion, and severe personnel injury or death. Do not operate a diesel-powered generator set where a flammable vapor environment can be created by fuel spill, leak, etc.

1.9 Battery Gas Is Explosive

WARNING

Battery gas is highly explosive and may cause personal injury or death if ignited. Take the proper precautions to avoid personal injury.

- *For personal safety, wear appropriate PPE when working on or around the generator set.*
- *To make sure battery gas is not ignited, do not smoke around the generator set.*
- *To reduce arcing when disconnecting or reconnecting battery cables, always disconnect the negative (-) battery cable first and reconnect it last.*

1.10 Moving Parts Can Cause Severe Personal Injury or Death

WARNING

Moving parts can cause severe personal injury or death, and hot exhaust parts can cause severe burns. Make sure all protective guards are properly in place before starting the generator set.

WARNING

Hot moving, and electrically live parts can cause severe personal injury or death. Keep children away from the generator set.

WARNING

Hot, moving, and electrically live parts can cause severe personal injury or death. Only trained and experienced personnel should make adjustments while the generator set is running.

WARNING

Moving parts can catch on loose items such as clothing or jewelry. Do not wear loose clothing or jewelry near moving parts such as PTO (power take-off) shafts, fans, belts, and pulleys.

WARNING

Moving parts can entangle appendages such as fingers. Keep the protective guards in place over fans, belts, pulleys, and other moving parts and keep hands away from all moving parts.

1.11 CARB

CAUTION

Unauthorized modifications or replacement of fuel, exhaust, air intake, or speed control system components that affect engine emissions are prohibited by law in the state of California.

The California Air Resources Board (CARB) has requirements regarding modification & repair of fuel system & exhaust components including, but not limited to, adherence to evaporative emissions requirements in mobile installations. Evaporative generator sets must be used in trailers, fifth wheel trailers, and other non-motorized vehicles where on-board gasoline fuel storage is self-contained in the trailer equipment. Completing the installation of the generator set fuel evaporative system provides compliance with the California code of regulations for small off-road equipment effective January 1, 2008 and Federal Small SI regulation effective January 1, 2011. Any questions regarding the installation or evaporative emission certification should be directed to Cummins Inc. for clarification.

1.12 Generator Set Warning Labels

Warning signs are provided on the generator set at or near the point of risk. To avoid injury, always take the necessary precautions as indicated on the sample signs shown below.

	<p>Caution or Warning. Indicates a risk of personal injury.</p>
	<p>Caution or Warning of Temperature Hazard. Indicates a risk of personal injury from high temperature.</p>
	<p>Caution or Warning of High Voltage Hazard. Indicates a risk of personal injury from electric shock or electrocution.</p>
	<p>Caution or Warning of Engine Coolant Pressure Hazard. Indicates a risk of personal injury from hot pressurized engine coolant.</p>
	<p>Caution or Warning. Indicates to read Operator Manual for additional information.</p>
	<p>Caution or Warning of No Step. Indicates a risk of personal injury or equipment damage from stepping on equipment.</p>
	<p>Caution or Warning of Combustion or Explosion Hazard. Indicates a risk of personal injury from explosion.</p>
	<p>Caution or Warning of Belt and Rotating Part Hazard. Indicates a risk of personal injury from entanglement in moving parts.</p>
	<p>Caution or Warning of Chemical (ingestion or burn) Hazard. Indicates a risk of personal injury or asphyxiation from poisonous fumes or toxic gases.</p>
	<p>Caution or Warning of High Voltage or Current Source Hazard. Indicates a risk of personal injury from electrical shock or electrocution.</p>
	<p>Caution or Warning of Fan and Rotating Part Hazard. Indicates a risk of personal injury from entanglement in moving parts.</p>

This page is intentionally blank.

2 Introduction

2.1 About this Manual

This is the Operator Manual for the generator set or sets listed on the front cover. Each operator should study this manual carefully and observe all of its instructions and safety precautions. Keep this manual readily available for reference.

The information contained within the manual is based on information available at the time of printing. In line with Cummins Inc. policy of continuous development and improvement, information may change at any time without notice. The users should therefore make sure that before commencing any work, they have the latest information available. The latest version of this manual is available on QuickServe Online (<https://quickserve.cummins.com>).

The Operation, Maintenance, and Troubleshooting Chapters of this manual provide instructions necessary for operating the generator set and maintaining it at top performance. The owner is responsible for performing maintenance in accordance with the information provided in [Chapter 5 on page 29](#).

This manual also includes generator set specifications and information on how to obtain service, emissions regulation compliance, and model identification.

See the Parts Manual for part identification numbers and required quantities. Genuine Cummins replacement parts are recommended for best results.

2.2 Related Literature

Before any attempt is made to operate the generator set, the operator should take time to read all of the manuals supplied with the generator set, and to familiarize themselves with the warnings and operating procedures.

CAUTION

A generator set must be operated and maintained properly if you are to expect safe and reliable operation. The Operator manual includes a maintenance schedule and a troubleshooting guide. The Health and Safety manual must be read in conjunction with this manual for the safe operation of the generator set:

- Health and Safety Manual (0908-0110)

The relevant manuals appropriate to your generator set are also available, the documents below are in English:

- Operator Manual for Commercial Mobile Generator Set (0981-0161)
- Installation Manual for Commercial Mobile Generator Set (0981-0623)
- Service Manual for HDKAH–K (Spec A–N) and HDKAT–V (Spec A–P) (0981-0522)
- Recommended Spares List (RSL) for RV Generator Set (HDKAT) (A043T624)
- Recommended Spares List (RSL) for RV Generator Set (HDKAT, Spec E) (RSL-514)
- Recommended Spares List (RSL) for GV Generator Set (HDKAT, Spec N) (A043T630)
- Recommended Spares List (RSL) for RV Generator Set (HDKAU, Spec N) (A043T632)

- Recommended Spares List (RSL) for RV Generator Set (HDKAV, Spec N) (A043T634)
- Parts Manual for RV Generator Set (HDKAH-V, Spec A-K) (0981-0200)
- Parts Manual for Commercial Mobile Generator Set (HDKAT-V, Spec L-P) (A029S841)
- Standard Repair Times – AK Family (0900-0615)
- Service Tool Manual (A043D529)
- Failure Code Manual (F1115C)
- Engine Operation & Maintenance Manual for Kubota, 68 mm Stroke Series (0981-0514)
- Warranty Administration Manual (4021290)
- Global Commercial Warranty Statement (A028U870)

2.3 Model Identification

Each generator set is provided with a nameplate that contains the model and serial numbers. This information is needed when contacting Cummins for parts, service, and product information.

Every character of the model number is significant. The last character of the model number is the specification letter which is important for obtaining the correct parts.

Record the generator set model and serial numbers in the figure below to have them available if needed.

2.3.1 Nameplate Location

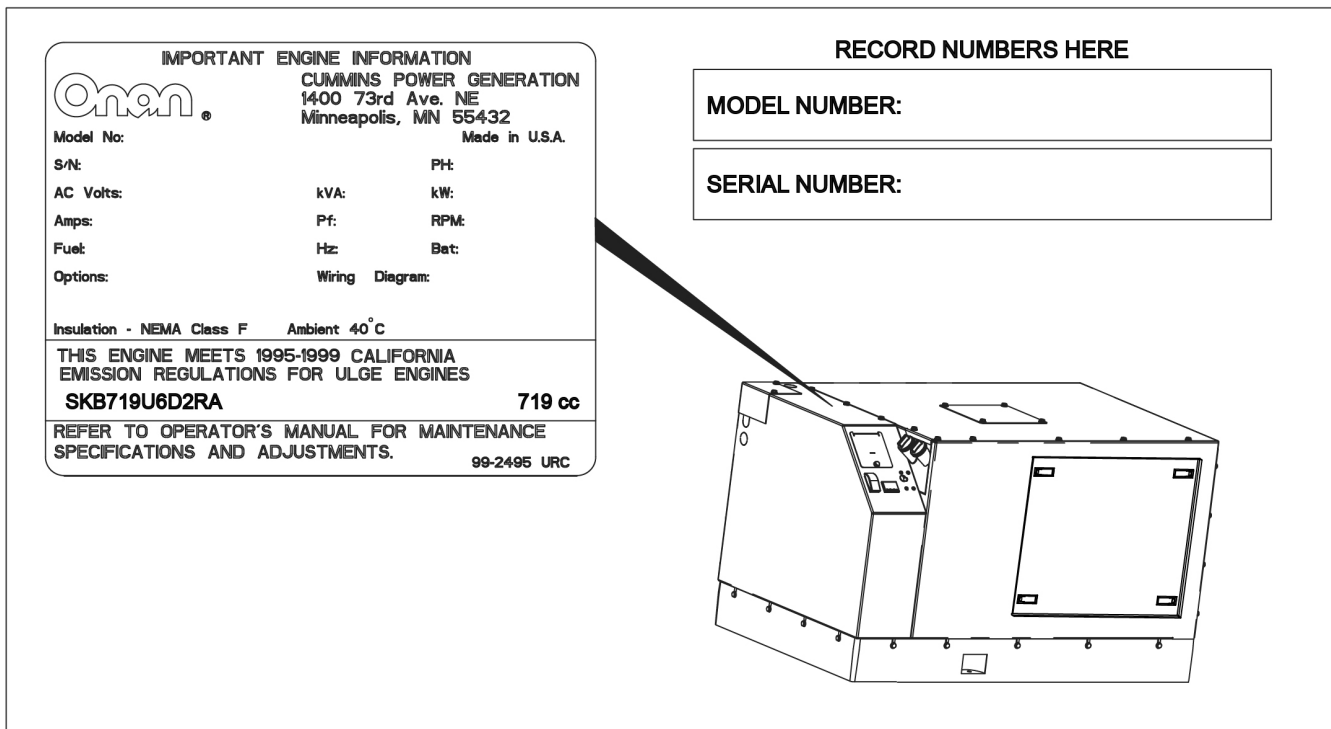

FIGURE 1. NAMEPLATE LOCATION

2.4 How to Obtain Service

For generator set parts, service, and literature, contact the nearest authorized Cummins Inc. distributor. You may go to the Internet site power.cummins.com for information on contacting our distributors worldwide.

2.4.1 In U.S. and Canada

Call +1-800-CUMMINS™ (1-800-286-6467) for the nearest Cummins Inc. distributor in the United States or Canada. Press 1 (option 1) to be automatically connected.

If you are unable to contact a distributor using the automated service, consult the Yellow Pages. Typically, our distributors are listed under: generators - electric.

2.4.2 Outside U.S. and Canada

If you are outside U.S. and Canada, refer to power.cummins.com or send an email to ask.powergen@cummins.com.

2.4.3 Information To Have Available

- model number
- serial number
- date of purchase
- nature of the problem (see [Chapter 6 on page 47](#))

This page is intentionally blank.

3 Overview

3.1 Electromagnetic Compatibility Compliance

Generator sets emit and receive electromagnetic (radio frequency) energy. If the generator set affects operation of nearby devices, or nearby devices affect generator set operation, increase the distance between them.

When used in countries where compliance to the EMC directive is required: This generator set has been evaluated for use in the residential, commercial, and light industrial environments.

3.2 Information for Generator Set Users

This generator set meets the requirements of California Air Resources Board (CARB) as stated on the nameplate.

As a user of this generator set, please be aware that unauthorized modifications or replacement of fuel, exhaust, air intake, or speed control system components that affect engine emissions are prohibited. Unauthorized modification, removal, or replacement of the generator set label is prohibited.

Carefully review Operator (Owner), Installation, and other manuals and information you receive with the generator set. If unsure that the installation, use, maintenance, or service of the generator set is authorized, seek assistance from an approved Cummins dealer.

Generator set users may use the following table as an aid in locating information related to the CARB requirements for emissions control.

TABLE 1. EMISSIONS CONTROL INFORMATION

Generator Set Warranty Information	The emissions control warranty statement is located in the same packet of information as this manual when the generator set is shipped from the factory.
Engine Valve Lash	See Section 3.4 on page 15 .
Engine Fuel Requirements	The engine is certified to operate on diesel fuel. See Section 5.6 on page 34 for fuel recommendations.
Engine Lubricating Oil Requirements	See Section 5.5 on page 31 for engine oil recommendations.
Engine Adjustments	High idle speed. This is a service procedure requiring trained personnel and proper tools. See the Service Manual.
Engine Emission Control System	The engine emissions control system consists of engine design and precision manufacture (IFI).

3.3 Build Standards

The generator set and its control system have been designed, constructed and tested generally in accordance with the following Standards where applicable.

Standard	Title
BS EN 1037:1995+a1:2008	Safety of machinery - Prevention of unexpected start up.
BS EN ISO 14121-1:2007	Safety of machinery. Risk assessment principles.
BS EN ISO 13857:2008	Safety of machinery. Safety distances to prevent hazard zones being reached by upper and lower limbs.
BS EN 349:1993+A1:2008	Safety of machinery - Minimum gaps to avoid crushing parts on the human body.
BS EN 547-1:1996+A1:2008	Safety of machinery - Human body dimensions - Part 1: Principles for determining the dimensions required for openings for whole body access into machinery.
BS EN 547-2:1996+A1:2008	Safety of machinery - Human body dimensions - Part 2: Principles for determining the dimensions required for access openings.
BS EN 547-3:1996+A1:2008	Safety of machinery - Human body dimensions - Part 3: Anthropomorphic data.
BS EN 60204-1:2006+A1:2009	Safety of machinery. Electrical equipment of machines. General requirements.
BS EN 614-1:2006+A1:2009	Safety of machinery. Ergonomic design principles. Terminology and general principles.
BS EN 953:1997+A1:2009	Safety of machinery - Guards - General requirements for the design and construction of fixed and movable guards.
BS EN ISO 12100-1:2003+A1:2009	Safety of machinery. Basic concepts, general principles for design. Basic terminology, methodology
BS EN ISO 12100-2:2003+A1:2009	Safety of machinery. Basic concepts, general principles for design. Technical principles
BS EN ISO 13732-1:2008	Ergonomics of the thermal environment. Methods for the assessment of human responses to contact with surfaces. Hot surfaces
BS EN ISO 13849-1:2008	Safety of machinery - Safety-related parts of control systems
BS EN ISO 13850:2006	Safety of machinery - Emergency stop. Principles for design.
BS EN 61310-1:2008	Safety of machinery - Indication, marking and actuation - Part 1: Requirements for visual, auditory and tactile signals.
BS EN 61310-2:2008	Safety of machinery - Indication, marking and actuation - Part 2: Requirements for marking.
BS EN 61000-6-1:2007	Electromagnetic compatibility (EMC). Generic standards. Immunity standard for residential, commercial and light-industrial environments.
BS EN 61000-6-3:2007	Electromagnetic compatibility (EMC). Generic standards. Emission standard for residential, commercial and light-industrial environments.
BS EN 1299:1997+A1:2008	Mechanical vibration and shock - Vibration isolation of machines - Information for the application of source isolation
BS EN 1679-1:1998	Reciprocating internal combustion engines - Safety - Part 1: Compression ignition engines
BS EN 12601:2001	Reciprocating internal combustion engine driven generating sets - Safety

3.4 Specifications

3.4.1 Diesel Model Specifications

TABLE 2. DIESEL MODEL SPECIFICATIONS

	HDKAT	HDKAU	HDKAV
GENERATOR SET CONTROLLER: Integrated Microprocessor Based Engine and Generator Control			
ALTERNATOR: Brushless, Exciterless, Bearingless, Permanent Magnet Alternator			
AC OUTPUT RATINGS:			
Power (@1.0 power factor)	7500 W	8000 W	6000 W
Frequency	60 Hz	60 Hz	60 Hz
Voltage	120 Volts	120 Volts	120 Volts
Number of Phases	1	1	1
Current	62.5 Amps	66.7 Amps	50.0 Amps
Line Circuit Breaker(s)	2-pole, 30 or 35 Amp	2-pole, 30 or 35 Amp	2-pole, 30 Amp
FUEL CONSUMPTION:			
No Load	.49 l/h (.13 gph)	.49 l/h (.13 gph)	.49 l/h (.13 gph)
Half Load (4000 W)	1.85 l/h (.40 gph)	1.85 l/h (.49 gph)	1.85 l/h (.49 gph)
Full Load	3.63 l/h.96 gph (.96 gph)	3.86 l/h (1.02 gph)	3.03 l/h (.80 gph)
ENGINE: 3-Cylinder In-Line, Water-Cooled, Indirect-Injection, 4-Stroke Cycle Diesel			
Bore	67 mm (2.64 inch)		
Stroke	68 mm (2.68 inch)		
Displacement	719 cc (44 inch ³)		
Stroke	68 mm (2.68 inch)		
Compression Ratio	23:1		
Intake and Exhaust Valve Lash (Cold)	0.165 mm (0.0065 inch)		
Oil Capacity (with filter)*	2.6 l (3 quart)		
Cooling System Capacity**	4 l (4.2 quart)		
OPERATING SPEED RANGE:	1600 to 3200 RPM	1600 to 3300 RPM	1600 to 2900 RPM
DC SYSTEM:			
Nominal Battery Voltage	12 Volts		
Minimum Battery Capacity CCA	450 CCA*** down to -17° C (0° F) 650 CCA*** down to -29° C (-20° F)		
Maximum Regulated Charging Current	10 Amp		
Fuse F1 (control circuit)	15 Amp mini-bayonet		

	HDKAT	HDKAU	HDKAV
Fuse F2 (starter solenoid circuit)	15 Amp mini-bayonet		
Fuse F3 (glow plug circuit)	25 Amp		
INSTALLATION:			
Weight (wet)	191 kg (420 lbs)		
Size (L x W x H)	922 x 599 x 566 mm (36.3 x 23.6 x 22.3 inch)		
* See oil filling instructions.			
** Includes coolant recovery tank.			
*** Cold Cranking Amps @ -17° C (0° F)			

3.5 List of Acronyms

TABLE 3. ACRONYM DEFINITIONS

Acronym	Definition
AC	Alternating Circuit
AGS	Automatic Generator Start
CCA	Cold Cranking Amp
CO	Carbon Monoxide
DC	Direct Current
GFCI	Grounded Fault Circuit Interrupters
LED	Light-emitting Diode
NFPA	National Fire Protection Agency
RV	Recreational Vehicle
RVIA	RV Industry Association
SAE	Society of Automotive Engineers

TABLE 4. ACRONYMS FOR UNITS OF MEASUREMENT

Acronym	Definition
Amp	Ampere
C	Celsius
F	Fahrenheit
Hz	Hertz
kW	kilowatt
lb	Pound
M	Meters

Acronym	Definition
mm	millimeters
RPM	Revolutions per Minute
V	Volts
VDC	Volts Direct Current
W	Watts

This page is intentionally blank.

4 Operation

4.1 Key Component Locations

The control panel and the components of a typical generator set requiring attention during periodic maintenance (see [Section 5.1 on page 29](#)) are shown in the figure below. There may be some variation depending on the generator set model.

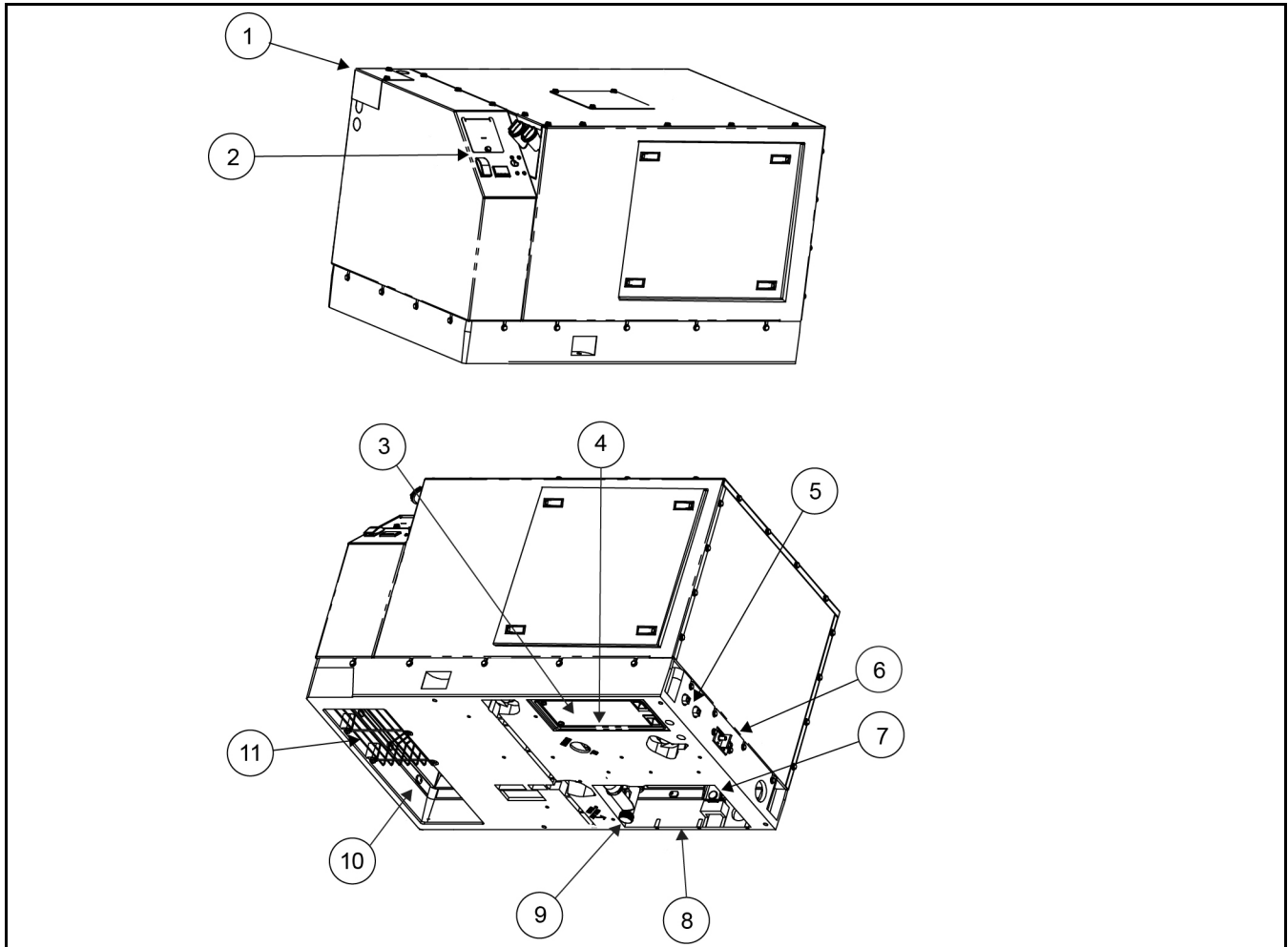

No.	Description	No.	Description
1	AC Terminal Box Cover	7	Exhaust Tailpipe Flange (Not Visible)
2	Control Panel	8	Warm Air Discharge Opening
3	Access Door for Oil and Fuel Filters	9	Coolant Drain Cap
4	Oil Drain Plug	10	Access to Air Filter
5	Fuel Connections	11	Cooling Air Inlet Grille
6	Battery Connections		

FIGURE 2. KEY COMPONENT LOCATIONS

4.2 Control Panel

4.2.1 Generator Set Control Panel

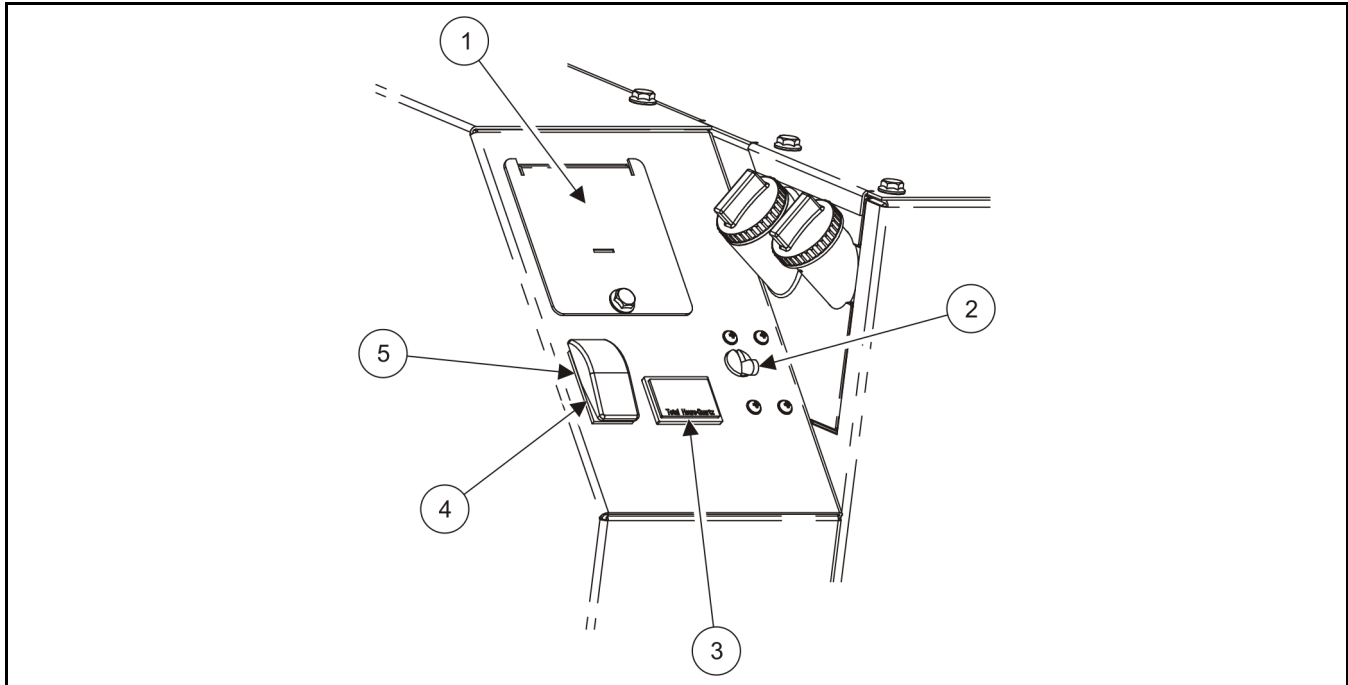

No.	Name	Description
1	Access Plate	Provides access to the fuses (F1, F2, F3) that protect the control circuits, and the coolant pressure cap which allows coolant to be filled.
2	Line Circuit Breaker	Protects the AC power leads connected to the generator set from overloads and equipment short circuits.
3	Hour Meter (optional)	Records the total running time of the generator set. Cannot be reset.
4	Control Switch	Used to start and stop the generator set, and to prime the engine fuel system.
5	Status Indicator	LED in the control switch that blinks rapidly during preheat and cranking. Stays on continuously after generator set is running. If the generator set shuts down abnormally, the indicator flashes a numerical code to indicate the cause of the shutdown (see [Troubleshooting]).

FIGURE 3. GENERATOR SET CONTROL PANEL

4.2.2 Remote Control Panel

A remote control panel may be installed inside the vehicle. There are 3 remote control panel kits available.

- Control switch with status indicator.
- Control switch with status indicator and an hour meter.
- Control switch with status indicator and a DC voltmeter.

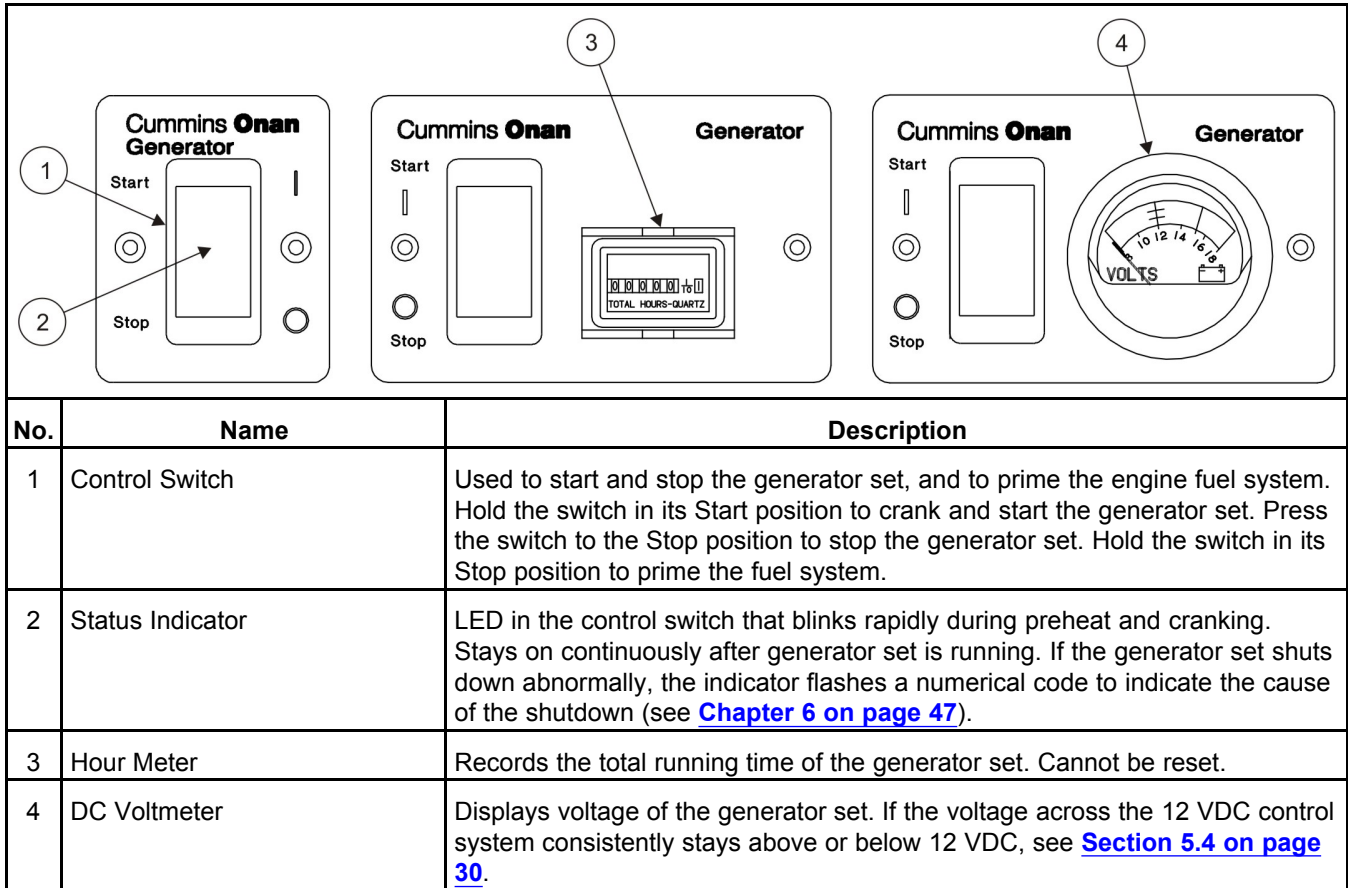

FIGURE 4. REMOTE CONTROL PANELS

4.3 Starting and Stopping the Generator Set

4.3.1 Pre-start Checks

WARNING

EXHAUST GAS IS DEADLY!

Exhaust gases contain carbon monoxide, an odorless, colorless gas. Carbon monoxide is poisonous and can cause unconsciousness and death. Symptoms of carbon monoxide poisoning include:

- *Dizziness*
- *Muscular twitching*
- *Weakness and sleepiness*
- *Throbbing in temples*
- *Headache*
- *Inability to think clearly*
- *Nausea*
- *Vomiting*

IF YOU OR ANYONE ELSE EXPERIENCES ANY OF THESE SYMPTOMS, GET OUT INTO THE FRESH AIR IMMEDIATELY. If symptoms persist, seek medical attention. Shut down the generator set and do not operate it until it has been inspected and repaired.

Never occupy the vehicle with the generator set running unless the vehicle is equipped with a working carbon monoxide detector. However, primary protection against inhaling carbon monoxide is proper installation of the exhaust system, and daily (every 8 hours) inspection for visible and audible exhaust system leaks.

Perform pre-start checks before the first start of the day and after every 8 hours of operation. See [Chapter 5 on page 29](#) if the vehicle has been in storage.

1. Make sure all vehicle CO detectors are working properly.
2. Remove access cover.
3. Inspect the generator set as instructed in [Chapter 5 on page 29](#).
4. Perform any maintenance due ([Section 5.1 on page 29](#)).
5. Keep a maintenance log ([Chapter 7](#)).
6. Check for signs of fuel and exhaust leaks and for damage to the exhaust system.
7. Replace access cover.
8. Turn off the air conditioner and other large appliances.

4.3.2 Priming the Fuel System

The fuel system should be primed after the fuel filter is replaced or after the generator set runs out of fuel.

Position the control switch to **STOP/PRIME** for 30 seconds. The status indicator stays on while the pump is on.

4.3.3 Starting the Generator Set

1. Visually inspect for fuel and exhaust leaks. Do not start the generator set until any fuel or exhaust leak is repaired.
2. Position and hold the control switch to **START** until the generator set starts. The status indicator on the switch flashes while cranking. It will stay on continuously when the generator set is running.
3. If the generator set fails to start, cranking will stop in approximately 30 seconds. The status indicator will blink, indicating an over crank fault. Wait 5 seconds for the control to reset before trying again. After 5 tries, let the starter motor cool down for 30 seconds before trying again. See [Chapter 6 on page 47](#) if the generator set does not start after several tries.

CAUTION

The starter motor can be damaged by overheating. Allow it to cool down for 30 seconds after every fifth crank.

4. For top performance and engine life, especially in colder weather, let the engine warm up for 2 minutes before connecting appliances.
5. See [Chapter 6 on page 47](#) if the generator set shuts down and the status indicator blinks, indicating a fault.

4.3.4 Stopping the Generator Set

1. Turn off the air conditioner and other large appliances.
2. Run generator set for 2 minutes to allow for cool down.
3. Press the control switch in its **STOP** position.

4.4 Loading the Generator Set

The power rating (kW) on the generator set nameplate determines how much electrical load (motors, fans, heaters, air conditioners, and other appliances) the generator set can power. If the sum of the loads exceeds the generator set power rating, the generator set will shut down or its line circuit breakers will trip.

NOTICE

It may be necessary to run fewer appliances at the same time—the sum of the loads must not be greater than the generator set power rating.

To avoid shutdowns due to generator set overload, use the electrical ratings on the nameplates of equipment (if available) to compare the sum of the electrical loads that are likely to be used at the same time to the generator set power rating. Refer to the table below for typical appliance ratings.

Appliance load and generator set power are measured in terms of Watts (W) or kilowatts (kW), where 1 kilowatt (kW) = 1000 Watts (W).

- If the equipment is marked in Amps and Volts only, multiply the Amps times the Volts to obtain the load in Watts.
- Divide Watts by 1000 to obtain load in terms of kilowatts.

It is possible that the generator set circuit breaker may trip even though the sum of the steady state loads is less than the generator set power rating. When a large motor or air conditioner is started last or cycles off and on, the startup load is larger than its normal running load, causing the load to temporarily exceed the generator set power rating.

Typical "invisible" charging loads:

- During startup, air conditioners need "reserve" power and can draw 3–4 times the typical 1400–2400 Watts needed to run. Too much baseload can prevent air conditioners from starting.
- Battery chargers are activated automatically and can draw a large load (up to 3000 Watts). Manage electrical loads by adjusting battery charge rates to best suit your needs. Consult your inverter/charger manual or manufacturer.

TABLE 5. TYPICAL APPLIANCE LOADS

Appliance	Average Required Wattage	Amps
Air Compressor (1hp)	900-1800	7.5-15
Air Conditioner	1200-2400	10-20
Battery Charger ¹	Up to 3000	6-28
Blender	450-700	3.3-5.8
Broiler	1400-1700	11.6-14
Broom/Vacuum	1000-1440	8.3-12
CD/mp3 Player & Speakers	85	0.7
Coffeepot	900-1200	7.5-10
Computer	60-270	0.5-2.25
Laptop	20-50	0.16-0.41
Converter	500-1000	4-8
Curling Iron	20-50	0.16-0.41
Dishwasher	1200-2400	10-20
Drill	250-1000	2-8
Electric Blanket	60-100	0.5-0.8
Fan	10-175	0.08-1.45
Flat Iron	40-80	0.3-0.6
Frying Pan/Wok	1000-1350	8-11.25
Game Console	19-200	0.16-1.6
Hair Dryer	1200-1875	10-15.6
Iron	1000-1800	8-15
Light Bulbs	13-100	0.1-0.8
Microwave/Convection Oven	750-1100	6.25-9.2
Radio	50-200	0.4-1.6
Refrigerator	400-1000	3.3-8
Shaver	15-20	0.12-0.16
Space Heater	750-1500	6.25-12.5
Stove	900-2500	7.5-20.8

Appliance	Average Required Wattage	Amps
Television	43-600	0.35-5
Toaster	800-1400	6.6-11.6
VCR/DVD/Blu-ray Player	6-30	0.05-0.25
Washer/Dryer	350-500/1800-5000	3-4/15-42
Water Heater	1000-1500	8-12.5
Water Pump	250-1100	2-9.16

¹ Battery chargers can be a source of significant load and will be on whether they are connected to shore power or the generator set.

4.4.1 Power Versus Altitude

The generator set is rated at standard barometric pressure, humidity, and air temperature (reference ISO 3046). Low barometric pressure (high altitude) or high ambient temperature decreases engine power.

- As ambient temperature increases, rated generator set engine power decreases approximately 1% for every 5.5 °C (10 °F) above 25 °C (77 °F).
- Power decreases approximately 3.5% of rated power each 305m (1000 ft) of increase in elevation. Refer to the table below for typical elevation/generator set power calculations.

NOTICE

It may be necessary to run fewer appliances at higher altitudes and ambient temperatures.

TABLE 6. POWER VERSUS ALTITUDE

Elevation Above Mean Sea Level	Maximum Generator Set Power ¹	Maximum Generator Set Power ¹	Maximum Generator Set Power ¹
Up to 152m (500 ft)	6000 Watts (rated)	7500 Watts (rated)	8000 Watts (rated)
762m (2500 ft)	5580 Watts	7050 Watts	7520 Watts
1676m (5500 ft)	4950 Watts	6375 Watts	6800 Watts
Above 1676m (5500 ft)	4950 Watts minus 210 Watts each 305m (1000 ft)	6375 Watts minus 225 Watts each 305m (1000 ft)	6800 Watts minus 240 Watts each 305m (1000 ft)

1. Does not take into account the effect circuit breakers may have in limiting maximum power.

4.5 Exercising the Generator Set

Exercise the generator set at least 2 hours each month if use is infrequent. Run the generator set at approximately 1/2 rated power. A single 2-hour exercise period is better than several shorter periods.

Exercising a generator set drives off moisture, relubricates the engine, replaces stale fuel in fuel lines, and removes oxides from electrical contacts and generator slip rings. The result is better starting, longer engine life, and greater reliability.

4.6 Resetting Line Circuit Breakers

If a generator set line circuit breaker or a circuit breaker in the power distribution panel trips, either a short circuit has occurred or too many loads were connected.

NOTICE

The generator set continues to run if its circuit breaker trips.

If a circuit breaker trips:

1. Disconnect or turn off as many electrical loads as possible.
2. Reset the circuit breaker.
3. If the circuit breaker trips right away, either the appliance (or electrical load) has a short or the circuit breaker is faulty. Call a qualified electrician.

NOTICE

It may be necessary to push the circuit breaker OFF to reset it and ON to reconnect the circuit.

4. If the circuit breaker does not trip right away, reconnect loads one-by-one making sure not to overload the generator set or cause a circuit breaker to trip. If a circuit breaker trips right away when an appliance is connected, that appliance or circuit probably has a short.

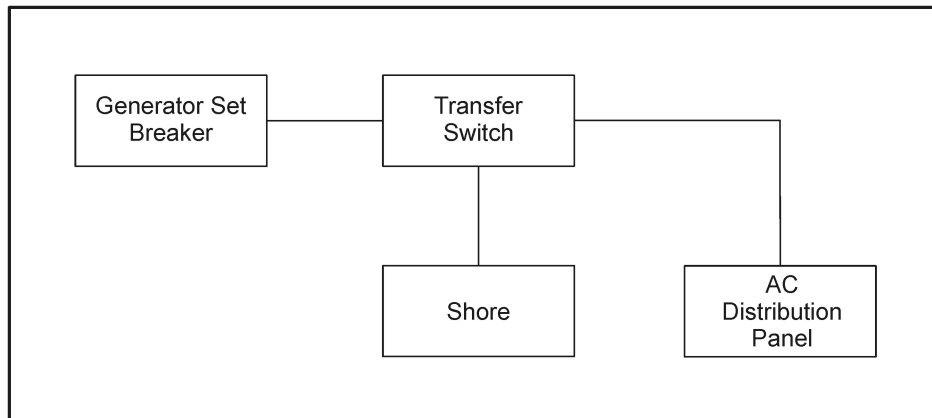

FIGURE 5. CIRCUIT BREAKER CONNECTIONS

⚠ WARNING

Short circuits in electrical equipment can cause fire and electrical shock leading to severe personal injury or death. Electrical equipment and its grounding must be maintained properly to protect against short circuits.

Electrical equipment must be used and maintained properly, and be properly grounded, to cause the line circuit breakers to trip when short circuits occur.

Electrical appliances and tools must be used and maintained in accordance with their manufacturer's instructions and safety precautions. Proper grounding is needed to reduce the risk of electric shock and fire.

4.7 Connecting Shore Power

⚠ WARNING

Interconnecting the generator set and shore power can lead to electrocution of utility line workers, equipment damage, and fire. Use an approved switching device to prevent interconnections.

A vehicle with provisions for connecting utility power must have an approved device to keep the generator set and utility from being interconnected. See the generator set Installation Manual for more information.

4.8 Operating in Weather Extremes

Pay particular attention to the following items when operating the generator set in cold or hot weather.

1. Make sure nothing blocks airflow to and from the generator set.
2. Make sure engine oil viscosity is appropriate for the ambient temperature. See [Section 5.5 on page 31](#) for engine oil recommendations.
3. Keep the generator set clean.
4. Perform maintenance due. See [Section 5.1 on page 29](#).

4.9 Operating in Dusty Environments

Pay particular attention to the following items when operating the generator set in dusty environments.

1. Do not let dirt and debris accumulate inside the generator set compartment. Keep the generator set clean.
2. Perform air filter element maintenance more often.
3. Change engine oil more often.

4.10 Care of New or Rebuilt Engine

Proper engine break-in on a new generator set or on one with a rebuilt engine is essential for top engine performance and acceptable oil consumption. Run the generator set at approximately 1/2 rated power for the first 2 hours and at 3/4 rated power for 2 more hours.

Proper engine oil and oil level are especially critical during break-in because of the higher engine temperatures that can be expected. Change the oil if the oil is not appropriate for the ambient temperatures during break-in. See [Section 5.5 on page 31](#) for engine oil recommendations.

Check oil level twice a day or every 4 hours during the first 24 hours of operation and change the oil after the first 50 hours of operation.

5 Maintenance

⚠ WARNING

Only authorized and competent personnel who are familiar with the equipment and its operation should carry out maintenance.

5.1 Periodic Maintenance

⚠ WARNING

Accidental starting can cause severe personal injury or death. Turn off the AGS whenever performing maintenance or service, when the vehicle is stored between uses, is awaiting service, or is parked in a garage or other confined area.

Periodic maintenance is essential for top performance and long generator set life. Use the Periodic Maintenance Schedule below for normal periodic maintenance. In hot and dusty environments some maintenance procedures should be performed more frequently, as indicated by the footnotes in the schedule. Keeping a log of maintenance performed and hours run will help keep generator set maintenance regular and provide a basis for supporting warranty claims (see [Chapter 7](#)).

Maintenance, replacement, or repair of emission control devices and systems may be performed by any engine repair establishment or individual. However, warranty work must be completed by an authorized Cummins Service Representative.

5.1.1 Periodic Maintenance Schedule

TABLE 7. PERIODIC MAINTENANCE SCHEDULE

MAINTENANCE PROCEDURE	MAINTENANCE FREQUENCY					
	Every Day	After First 50 Hours	Every Month	Every 150 Hours	Every 500 Hours	Every 1000 Hours
General Inspection	X					
Check Engine Oil Level	X					
Check Engine Coolant Level	X					
Clean and Check Battery			X ³			
Change Engine Oil and Filter		X ¹		X ^{2, 3, 4}		
Replace Engine Air Filter					X ^{2, 4}	
Replace Fuel Filter					X ⁸	
Check Coolant Anti-freeze Protection					X	
Flush Coolant System						X ⁵
Replace Coolant Pressure Cap						X ⁵
Replace Engine V-belt						X ⁶

MAINTENANCE PROCEDURE	MAINTENANCE FREQUENCY					
	Every Day	After First 50 Hours	Every Month	Every 150 Hours	Every 500 Hours	Every 1000 Hours
Clean Crankcase Breather						X ^{6, 7}
Replace Coolant Hoses and Thermostat						X ^{6, 7}
1 - As a part of engine break-in, change the engine oil after the first 50 hours of operation. 2 - Perform more often when operating in dusty environments. 3 - Perform more often when operating in hot weather. 4 - Perform at least once a year. 5 - Perform at least once every two years. 6 - Perform at least once every five years. 7 - Must be performed by a qualified mechanic (authorized Cummins Service Representative). 8 - Perform every 250 hours when using B20 Bio-diesel fuel.						

5.2 Consumable Parts

The following is a list of consumables associated with the generator models covered in this manual:

TABLE 8. CONSUMABLE PARTS

Part Number	Description	Quantity
122-0946	Filter, Oil	1
140-2897	Element, Air Cleaner	1
147-0860	Filter, Fuel	1

5.3 General Inspection

1. Check battery connections ([Section 5.4 on page 30](#)).
2. Check engine oil level ([Section 5.5 on page 31](#)).
3. Check engine coolant level ([Section 5.7 on page 38](#)).
4. Check fuel system ([Section 5.6 on page 34](#)).
5. Check exhaust system ([Section 5.8 on page 40](#)).
6. Check mechanical system ([Section 5.9 on page 41](#)).

5.4 Maintaining the Battery

The generator set requires a 12 Volt battery to power its control and starting circuits. Reliable generator set starting and starter service life depend upon adequate battery system capacity and maintenance.

⚠ WARNING**Fire Hazard**

Flames, sparks, or arcing at battery terminals, light switches, or other equipment can ignite battery gas, causing severe personal injury.

Ventilate the battery area before working on or near a battery, wear safety glasses, and do not smoke. Turn work light on or off away from the battery.

Refer to [Section 5.1 on page 29](#) for the battery maintenance schedule and follow the battery manufacturer's instructions. Have the battery charging system serviced if DC system voltage is consistently low or high.

Check the battery terminals for clean, tight connections. Loose or corroded connections have high electrical resistance which makes starting harder.

1. Keep the battery case and terminals clean and dry.
2. Keep the battery terminals tight.
3. Remove battery cables with a battery terminal puller.
4. Make sure which terminal is positive (+) and which is negative (-) before making battery connections, always removing the negative (-) cable first and reconnecting it last to reduce arcing.

5.5 Maintaining the Lubrication System

Keep dirt, water, and other contaminants from entering the lubrication system and corroding or clogging lubrication components.

5.5.1 Oil Level

Park the vehicle on level ground and stop the generator set before checking engine oil level.

⚠ WARNING**Hot Surfaces**

Contact with hot surfaces can cause severe burns, lacerations and liquid splash.

Wear appropriate PPE when working on hot equipment and avoid contact with hot surfaces.

⚠ WARNING**Crankcase Pressure**

Crankcase pressure can blow hot engine oil out the fill opening causing, severe burns.

Always stop the generator set before removing the oil fill cap.

⚠ WARNING**Toxic Hazard**

State and federal agencies have determined that contact with used engine oil can cause cancer or reproductive toxicity.

Avoid skin contact and breathing of vapors. Use rubber gloves and wash exposed skin.

NOTICE

Too little oil can cause severe engine damage. Too much oil can cause high oil consumption. Keep the oil level between the high and low beads (or markings) on the dipstick.

1. Pull out the dipstick.
2. Wipe off the dipstick and reinsert it.
3. Pull it out again to check oil level.
4. Add or drain oil as necessary. Keep the oil level between the full and add marks.
5. Insert the dipstick and secure the oil fill cap.

5.5.2 Engine Oil Recommendations

Use API (American Petroleum Institute) classified engine oils according to the following guidelines.

- In emissions regulated areas, it is mandatory to use CF, CF-4, CG-4, CH-4, or CI-4 class oil with:
 - Low sulfur fuel - sulfur content less than 500 ppm (0.05% weight).
 - Ultra low sulfur fuel - sulfur content less than 15 ppm (0.0015% weight).
- In non-emissions regulated areas, use high sulfur fuel.
 - If sulfur content is between 500 ppm (0.05% weight) and 5000 ppm (0.5% weight), CF class oil is recommended.
 - If sulfur content is between 5000 ppm (0.5% weight) and 10,000 ppm (1.0% weight), use CF, CF-4, CG-4, CH-4, or CI-4 class oil.

NOTICE

If high sulfur fuel is used, the oil and oil filter must be changed twice as often.

Look for the SAE (Society of Automotive Engineers) viscosity grade. Choose the viscosity grade appropriate for the ambient temperatures expected until the next scheduled oil change. Multigrade oils such as SAE 15W-40 are recommended for year round use.

TABLE 9. OIL VISCOSITY VS. TEMPERATURE

EXPECTED AMBIENT TEMPERATURES	SAE VISCOSITY GRADE
0 °C (32 °F) and higher	30
-12 to 38 °C (10 to 100 °F)	15W-40 (OnaMax)
-18 to 27 °C (0 to 80 °F)	10W-30 10W-40
-28 to 10 °C (-20 to 50 °F)	5W-30

5.5.3 Changing Engine Oil and Oil Filter

WARNING

Accidental or Remote Starting

Accidental or remote starting can cause severe personal injury or death.

Before removing a panel or access door, or before working on the generator set, use an insulated wrench to disconnect the negative (-) cable from the battery to prevent accidental starting.

WARNING

Hot Surfaces

Contact with hot surfaces can cause severe burns, lacerations and liquid splash.

Wear appropriate PPE when working on hot equipment and avoid contact with hot surfaces.

WARNING

Toxic Hazard

State and federal agencies have determined that contact with used engine oil can cause cancer or reproductive toxicity.

Avoid skin contact and breathing of vapors. Use rubber gloves and wash exposed skin.

Refer to [Section 5.1 on page 29](#) for the engine oil change schedule. Change oil more often in hot or dusty environments.

1. Run the generator set under load until it is up to operating temperature, stop it, and disconnect the negative (-) battery cable at the battery.

WARNING

Crankcase Pressure

Crankcase pressure can blow hot engine oil out the fill opening causing, severe burns.

Always stop the generator set before removing the oil fill cap.

2. Remove the oil fill cap.
3. Place a pan underneath the oil drain plug and remove the plug (see Oil Change Values and Drain Plug Location below). Let all oil drain from the engine.
4. Replace the plug.
5. Spin off the oil filter and thoroughly wipe off the filter mounting surface. Remove the gasket if it does not come off with the filter.
6. Apply a film of oil to the new filter gasket and spin the new filter on by hand until the gasket just touches the mounting pad. Tighten 1/2 to 3/4 of a turn.

NOTICE

Too little oil can cause severe engine damage. Too much oil can cause high oil consumption. Keep the oil level between the high and low beads (or markings) on the dipstick.

7. Refill with oil (see Oil Change Values below). Check the oil level and add or drain oil as necessary.

8. Screw the oil fill cap on securely.
9. Reconnect the negative battery cable.
10. Run the generator for a few minutes, shut it down, and recheck for proper oil level and leaks.
11. Dispose of the used oil and oil filter in accordance with local environmental regulations.

5.5.3.1 Oil Change Values and Drain Plug Location

TABLE 10. OIL CHANGE VALUES

Drain Plug Bolt	Plug Torque	Oil Amount
9/16 inch	6.78–13.56 Nm (5–10 ft-lbs)	2.6 liters (3 qt)

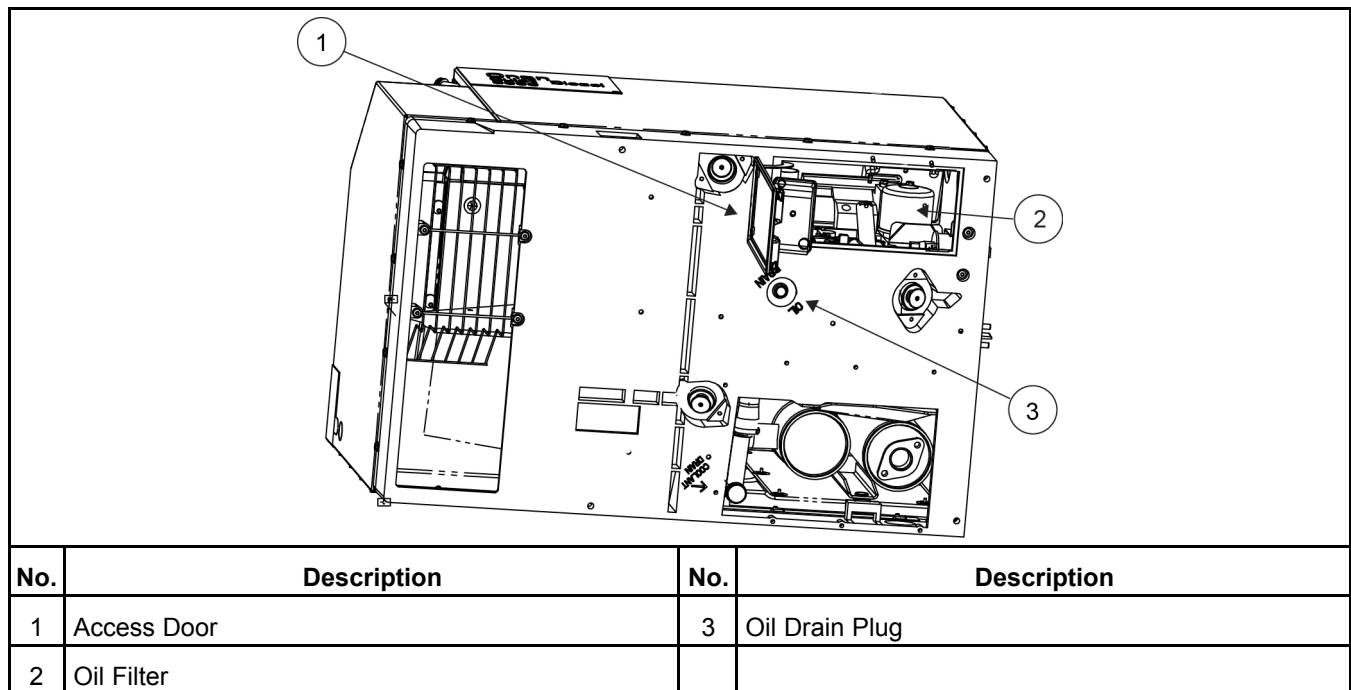

FIGURE 6. OIL DRAIN PLUG(S)

5.6 Maintaining the Fuel System

Keep dirt, water, and other contaminants from entering the fuel system and corroding or clogging fuel system components.

5.6.1 Fuel System

⚠ WARNING
<i>Diesel fuel leaks can lead to fire. Do not operate the generator set if operation causes fuel to leak.</i>

1. Check for leaks at the hose, tube, and pipe fittings in the fuel supply system while the generator set is running and while it is stopped.

2. Check flexible fuel hoses sections for cuts, cracks, abrasions, and loose hose clamps.
3. Make sure the fuel line does not rub against other parts of the vehicle or generator set.
4. Replace worn or damaged fuel line parts before leaks occur.

5.6.2 Fuel Recommendations

WARNING

Diesel fuel is combustible and can cause severe personal injury or death. Do not smoke near fuel tanks or fuel-burning equipment, or in areas sharing ventilation with such equipment. Keep flames, sparks, pilot flames, electrical arcs and switches, and all other sources of ignition well away. Keep a multi-class ABC fire extinguisher handy.

High quality diesel fuel is necessary for good performance and long engine life.

- The specifications for the type and sulfur content (ppm and weight percentage) of the diesel fuel used must comply with all emissions regulations applicable in the areas where the generator set is to be operated.
- Diesel fuels meeting ASTM D975 or EN 590 specifications are recommended. Use Grade 1-D diesel fuel.
 - When the ambient temperature is below $-10\text{ }^{\circ}\text{C}$ ($14\text{ }^{\circ}\text{F}$), a minimum Cetane number of 45 is recommended.
 - When the ambient temperature is below $-20\text{ }^{\circ}\text{C}$ ($-4\text{ }^{\circ}\text{F}$) or elevation is above 1500 m (5000 ft), a minimum Cetane number of 50 is recommended.
- Current US EPA regulations for non-road engines limit diesel fuel sulfur content to a maximum of 500 ppm (0.05% weight).
 - Use Grade 2-D S500 or 2-D S15 diesel fuel.
 - When the ambient temperature is below $-10\text{ }^{\circ}\text{C}$ ($14\text{ }^{\circ}\text{F}$), use Grade 1-D S500 or 1-D S15 diesel fuel.

NOTICE

Beginning in the year 2010, US EPA regulations limit diesel fuel sulfur content to a maximum of 15 ppm (0.0015% weight).

- Do not use diesel fuel with a sulfur content greater than 10,000 ppm (1.0% weight).
- Diesel fuel must meet the ASTM D975 standard for lubricity and pass a minimum load level of 3100 grams as measured by ASTM D6078, or maximum scar diameter of 0.45 mm as measured by ASTM D6079 or ISO 12156-1.

5.6.2.1 Bio-diesel Fuels B5 – B20

B5 bio-diesel fuel that meets industry specifications and quality is suitable for use with this generator set.

Before using bio-diesel fuel blends above B5 and up to B20, the following conditions must be verified:

- The vehicle propulsion engine is capable of using B20 when sharing the same fuel tank.
- The OEM has installed a B20 compatible fuel line from the fuel tank to the generator set.
- The OEM has installed a water separator in the fuel line just before the generator set.

For bio-diesel blends above B5 and up to B20, Cummins recommends that the fuel meet the specifications outlined in ASTM D7467. The bio-diesel component of this fuel blend must meet ASTM D6751 or EN14214, and the petroleum diesel component must meet ASTM D975. Blended bio-diesel fuels should be pre-blended and not made by customers.

⚠ CAUTION

Market applications contain properties that can affect engine operating characteristics. It is highly recommended that use of these bio-diesel fuel blends be avoided or exercised with extra care. Use standard fuels in applications that experience seasonal usage, storage for periods exceeding 90 days, and extreme temperatures or humidity.

The following bio-diesel fuel properties can affect engine performance:

- Poor oxidation stability can accelerate fuel oxidation. Fuel oxidation reduces generator performance. This effect is accelerated at increased ambient temperatures.
- Properties change at temperatures below $-5\text{ }^{\circ}\text{C}$ ($23\text{ }^{\circ}\text{F}$). Necessary precautions must be taken when operating the generator with bio-diesel blends in low ambient temperatures.
 - Fuel heater
 - Hose insulation
 - Additional anti-gel fuel additives.
- Bio-diesel fuel blends are an excellent medium for microbial growth. Microbes cause fuel system corrosion and premature filter plugging. The effectiveness of all commercially available conventional anti-microbial additives, when used in bio-diesel fuel, is not known. Consult your fuel and additive supplier for assistance.

If bio-diesel fuel is used for seasonal applications (stored more than 90 days), the generator must be purged before storage by running the engine on pure diesel fuel meeting ASTM D975 for a minimum of 30 minutes.

NOTICE

The Cummins Warranty covers failures that are a direct result of defects in material or factory workmanship. Generator damage, service issues, and/or performance issues determined by Cummins to be caused by bio-diesel fuel blends not meeting the specifications outlined in the applicable Installation, Operator, and Service Manuals are not considered to be defects in material or workmanship and may affect your generator's warranty.

5.6.3 Replacing the Fuel Filter

⚠ WARNING

Accidental or Remote Starting

Accidental or remote starting can cause severe personal injury or death.

Before removing a panel or access door, or before working on the generator set, use an insulated wrench to disconnect the negative (-) cable from the battery to prevent accidental starting.

⚠ WARNING**Hot Surfaces**

Contact with hot surfaces can cause severe burns, lacerations and liquid splash.

Wear appropriate PPE when working on hot equipment and avoid contact with hot surfaces.

Refer to [Section 5.1 on page 29](#) for scheduled fuel filter replacement. Replace the fuel filter if the engine lacks power.

1. Let engine cool down to prevent igniting any fuel that may be spilled when disconnecting the fuel filter.
2. Remove the fuel line from the filter to the engine. Plug the fuel line to prevent fuel leakage and vapor accumulation.
3. Run the generator set until it runs out of fuel and let it cool down.
4. Disconnect the negative (-) cable at the battery to prevent the engine from starting.
5. Remove the tubing from the filter going to the fuel pump.
6. Remove the filter as follows:
 - For Legacy filter (square) remove the filter mounting nut and remove filter.
 - For the round filter, release bulkhead fitting and remove filter.
7. Replace the filter as follows:
 - For square filter, place filter in unit and attach with mounting nut.
 - For round filter, place filter in unit and secure bulkhead fitting.
8. Connect the fuel filter to the fuel lines and tubing.
9. Connect the negative (-) cable at the battery.
10. Prime the engine for at least 30 seconds to fill the new fuel filter.
11. Start the generator and allow to run for several minutes while checking for leaks.
12. Tighten the connections, if necessary.
13. Dispose of the old filter in accordance with local environmental regulations.

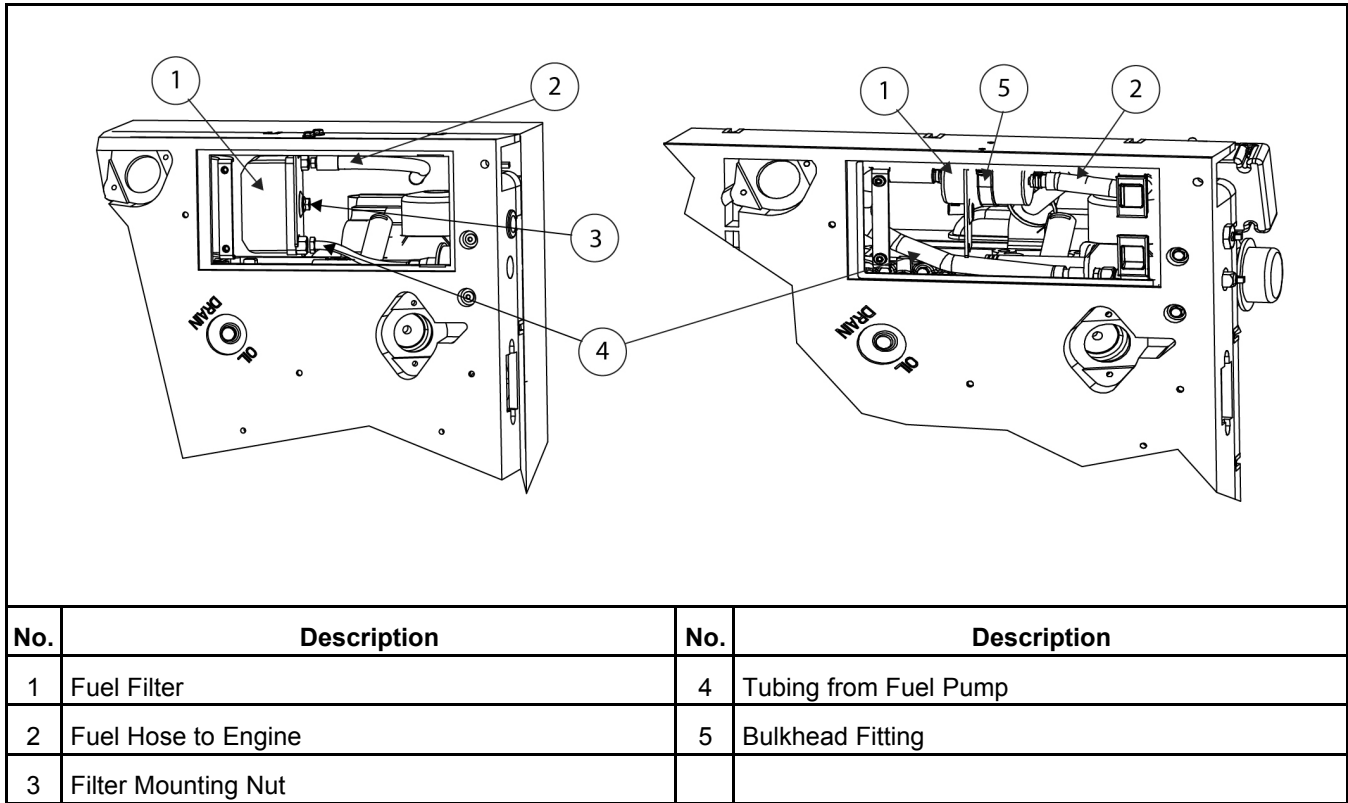

FIGURE 7. FUEL FILTER

5.7 Maintaining the Cooling System

The engine cooling system is filled with a 50/50 mixture of ethylene glycol antifreeze and water when the generator set leaves the factory. The mixture is suitable for temperatures down to -37 °C (-34 °F).

5.7.1 Cooling System

⚠ CAUTION
<i>Operating the generator set when coolant level is low can cause serious engine damage.</i>

Check the engine coolant level and look for coolant leaks around the bottom of the generator set and on the ground below. Minor leaks that can be replenished by daily additions of coolant to the recovery tank should be repaired by a qualified service technician as soon as possible. Larger leaks are cause for shutting down the generator set until it can be repaired.

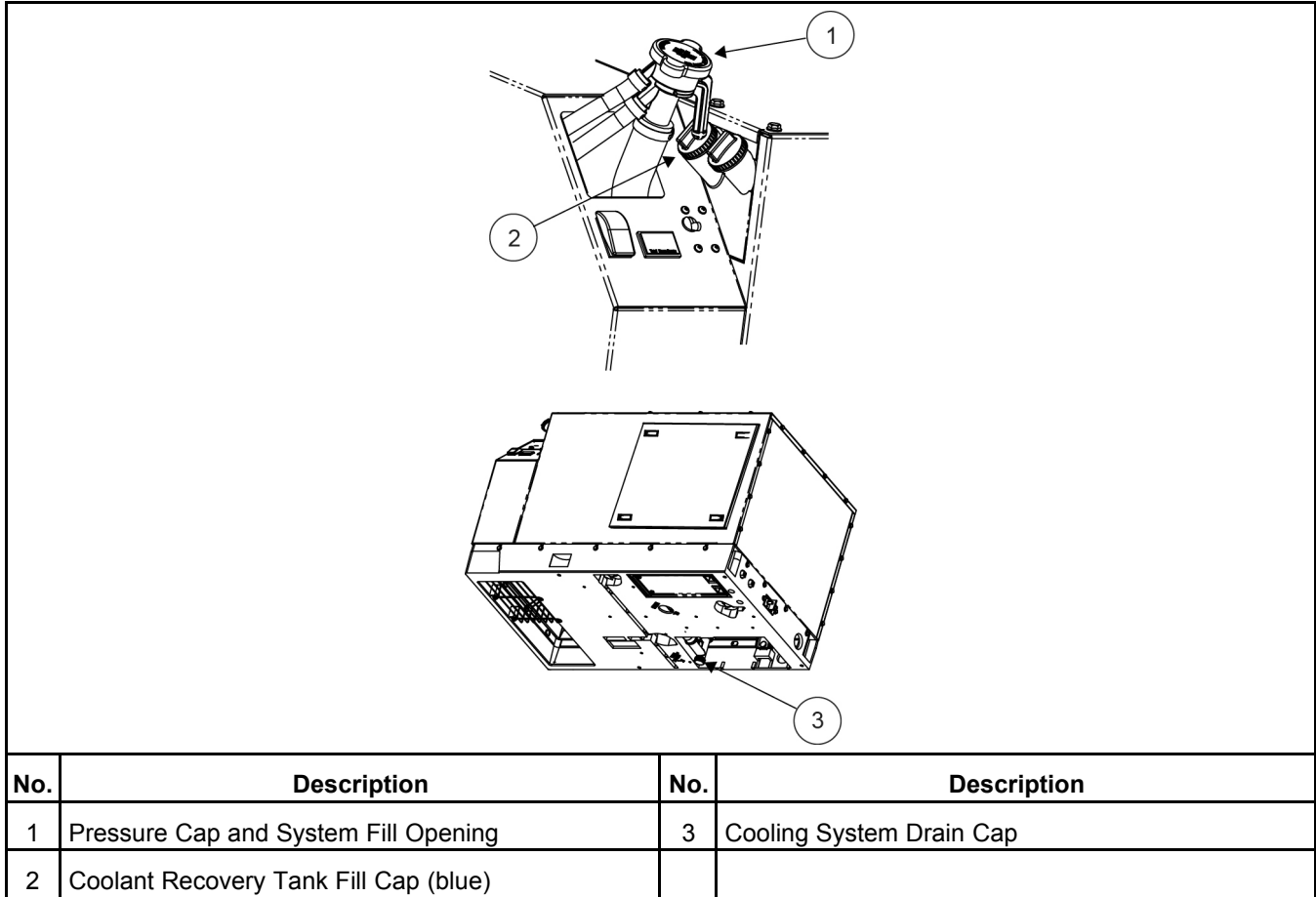

FIGURE 8. COOLING SYSTEM

5.7.2 Coolant Level

Check coolant level in the recovery tank before the first startup of each day and fill to the "COLD" mark if necessary.

5.7.3 Coolant Recommendations

Use the best quality ethylene glycol antifreeze available.

- Antifreeze should be fully formulated with rust inhibitors and coolant stabilizers.
- Mixed with fresh (distilled) water that is low in minerals and corrosive chemicals.

A 50/50 mixture is recommended for all climates and is suitable for temperatures down to -37 °C (-34 °F).

5.7.4 Draining and Cleaning Cooling System

⚠ WARNING
<i>Hot coolant spray can cause severe burns. Let the engine cool before releasing the pressure cap or removing the drain plug.</i>

Let the engine cool before removing the pressure cap.

1. Relieve any remaining pressure by turning the cap slowly, without pushing down.
2. When the pressure has been relieved, push down on the cap and turn it the rest of the way to withdraw it.

⚠ WARNING

Ethylene glycol antifreeze is considered toxic. Dispose of it according to local regulations for hazardous substances.

3. Remove the coolant drain plug and drain the coolant into a suitable container.

Flush and clean the cooling system before refilling. Radiator cleaning chemicals are available at local auto parts stores. Follow cleaning and flushing instructions on the product.

5.7.5 Refilling Cooling System

1. Install the coolant drain plug using pipe thread sealant.
2. Tighten it just enough to prevent leaks when the generator set is running and has warmed up.
3. Pull the hose connected to the pressure cap assembly out as far and high as it will go, and fill the system with coolant.
4. When the coolant level reaches the fill opening, start and operate the generator set for a few minutes and shut it down.
5. Add more coolant if necessary.
6. Secure the pressure cap.

5.8 Exhaust System

⚠ WARNING

EXHAUST GAS IS DEADLY! Do not operate the generator set if there is an exhaust leak or any danger of exhaust gasses entering or being drawn into the vehicle.

⚠ WARNING

Grass or brush in contact with the exhaust system can cause fire. Do not park the vehicle in high grass or brush.

1. Look and listen for exhaust system leaks while the generator set is running. Shut down the generator set if a leak is found and have it repaired before operating.
2. Look for openings or holes between the generator set compartment and vehicle cab or living space if the generator set engine sounds louder than usual. Have all such openings or holes closed off and sealed to prevent exhaust gases from entering the vehicle.
3. Replace dented, bent, or severely rusted sections of the tailpipe and make sure the tailpipe extends at least 25.4 mm (1 in) beyond the perimeter of the vehicle.
4. Park the vehicle so that generator set exhaust gases disperse away from the vehicle. Barriers such as walls, snow banks, high grass, brush, and other vehicles can cause exhaust gases to accumulate in and around the vehicle.
5. Do not operate power ventilators or exhaust fans while the vehicle is standing with the generator set running. The ventilator or fan can draw exhaust gases into the vehicle.

6. Check all CO monitors to assure proper operation.

5.9 Mechanical System

⚠ WARNING

Compressed air, pressure washers, and steam cleaners can cause severe eye injury. Always wear safety glasses when using.

1. Look for mechanical damage and listen for unusual noises and vibrations.
2. Check the generator set mounting bolts.
3. Check to see that the generator set air inlet and outlet openings are not clogged with debris or blocked.
4. Clean accumulated dust and dirt from the generator set. Do not clean the generator set while it is running or still hot. Protect the generator, air cleaner, control panel, and electrical connections from water, soap, and cleaning solvents.

5.10 Service Door

⚠ WARNING

Do not operate the generator set without the enclosure panel and service door secured in place. The enclosure panel and service door guard against rotating parts and bare live electrical parts that can cause severe personal injury or death.

No.	Description	No.	Description
1	Engine Side Enclosure Panel	4	Insulation
2	Screw (4)	5	Push Nut
3	Service Door		

FIGURE 9. SERVICE DOOR

1. Remove the 4 screws holding the service door on the engine side enclosure panel. Make sure that one hand is supporting the service door while the other hand is removing the screws.

2. Pull the service door straight out until the 2 studs are free from the insulation.
3. Set the service door aside and use a box cutter to cut the insulation along the edge of the rectangular opening as cleanly as possible.
4. Pull the insulation out and use push nuts to secure the cutout piece of insulation onto the service door.
5. Reinstall the service door with the attached piece of insulation onto the engine side enclosure panel.

5.11 Water Pump Belt Removal

1. Remove the negative (–) battery cable from the battery to prevent accidental starting of the generator set during removal.
2. Remove the 4 bolts which secure the pump pulley to its hub.
3. Pull the pulley and belt off.

5.12 Water Pump Belt Installation

CAUTION

Using the wrong water pump drive belt can lead to engine overheating.

NOTICE

Since there is no way to adjust the belt tension, it is critical that the correct replacement belt be used.

1. Place the belt over both pulleys.
2. Pull the pump pulley up to its hub and push the pulley onto the hub.
3. Secure the pulley with the 4 bolts and tighten to 39-45Nm (29-33 ft-lb).

NOTICE

Belt tension increases slightly as the engine runs and is sufficient for the relatively light pump load.

5.13 Replacing the Air Filter Element

WARNING

Accidental or Remote Starting

Accidental or remote starting can cause severe personal injury or death.

Before removing a panel or access door, or before working on the generator set, use an insulated wrench to disconnect the negative (-) cable from the battery to prevent accidental starting.

⚠ WARNING

Hot Surfaces
Contact with hot surfaces can cause severe burns, lacerations and liquid splash.
Wear appropriate PPE when working on hot equipment and avoid contact with hot surfaces.

Refer to [Section 5.1 on page 29](#) for scheduled air filter element replacement. Under dusty operating conditions, inspect and replace more often.

1. Remove the front access cover.
2. Remove the wing nut securing the air filter housing cover and remove the cover.
3. Remove the wing nut securing the filter cover plate and remove the cover plate.
4. Remove the air filter element.
5. Install the new air filter, making sure the filter element is centered over the carburetor air inlet.
6. Replace the filter cover plate and tighten wing nut.
7. Replace the air filter housing cover and tighten wing nut.

NOTICE

Do not tighten the wing nuts too tightly. Excessive tightening can distort the air filter element and cause air leaks around the element.

8. Replace the front access cover.

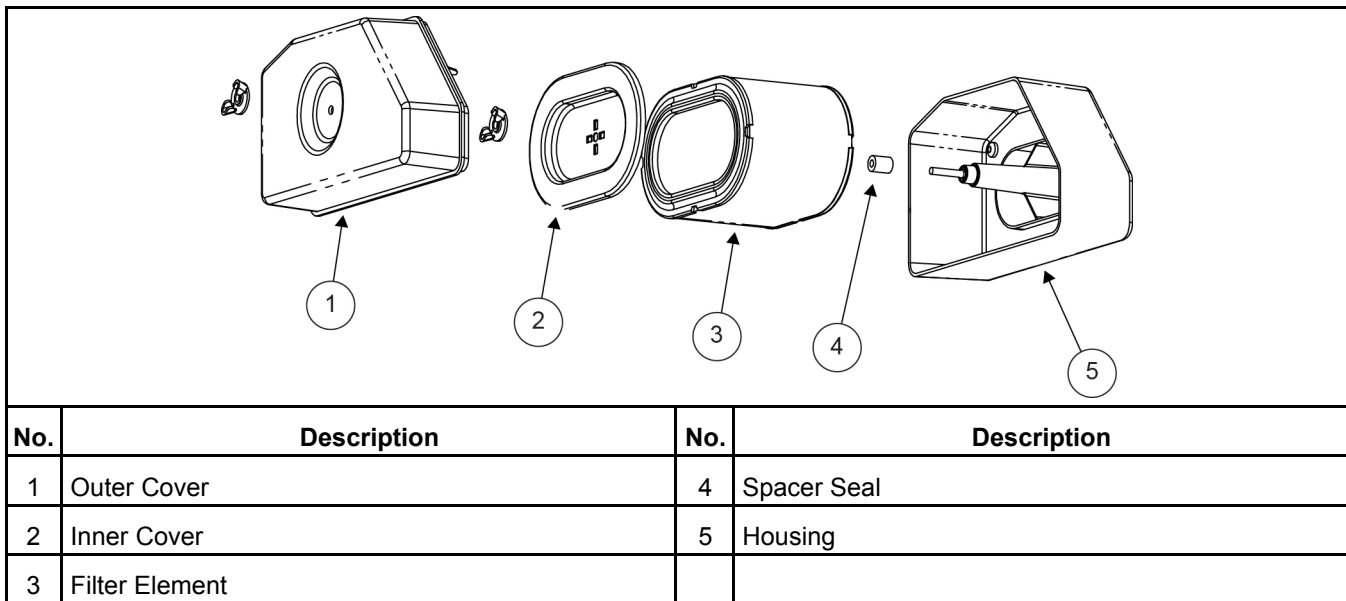

FIGURE 10. AIR FILTER ELEMENT

5.14 Cleaning the Spark Arrester

It may be necessary to clean out the spark arrester if the generator set is experiencing low power. Park the vehicle away from grass, brush or debris that could be ignited by sparks expelled during this procedure. The spark arrester meets U.S. Forest Service requirements.

⚠ WARNING

A hot muffler can cause severe burns. Let the muffler cool down before removing or installing spark arrester cleanout plugs or screens.

⚠ WARNING

Grass or brush in contact with the exhaust system can cause fire. Do not park the vehicle in high grass or brush.

1. Remove the cleanout plug.
2. Start and load the generator set to near full power. Let the generator set run for about 5 minutes to expel the soot in the muffler.
3. Stop the generator set, allow the muffler to cool, and reinstall the plug.

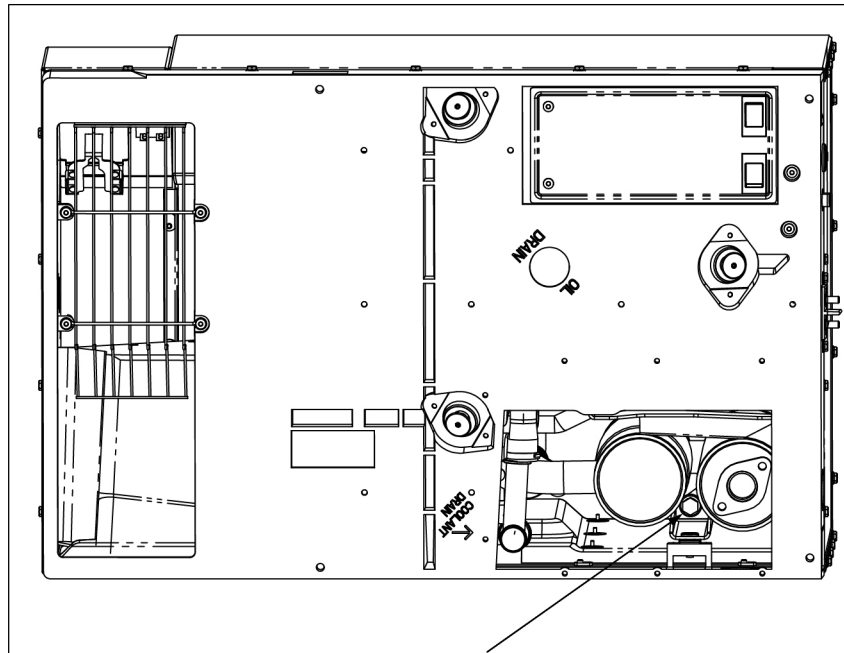

FIGURE 11. SPARK ARRESTER CLEANOUT PLUG

5.15 Storing the Generator Set

Proper storage is essential for preserving top generator set performance and reliability. If the generator set is not going to be exercised on a regular basis and not be used for more than 120 days, the generator set should be prepared for storage.

⚠ WARNING

Carbon monoxide is deadly and can accumulate to dangerous levels in garages and other confined spaces. Disable the automatic generator starting feature before storing the vehicle.

1. Disable the automatic generator set starting feature.
2. Change the engine oil and attach a tag indicating the oil grade viscosity.

3. Disconnect the battery cables, negative (–) cable first, from the starting battery and store the battery according to the battery manufacturer's recommendations.
4. Position the line circuit breaker to OFF.

5.16 Returning the Generator Set to Service

1. Check the oil tag on the generator set and change the oil if the viscosity indicated is not appropriate for the temperatures expected.
2. Reconnect the starting battery (negative [–] cable last).
3. Replace the air filter element. Use new air filter element if it is dirty.
4. Inspect the generator set.
5. Prime the generator set fuel system by positioning the control switch to **STOP/PRIME** for 30 seconds. The status indicator stays on while the pump is on.
6. Start the generator set.
7. Position the line circuit breaker to ON when the generator set is ready to power loads.

This page is intentionally blank.

6 Troubleshooting

6.1 Overview

WARNING

Hot engine parts can cause severe burns. Always allow the engine to cool down before performing any maintenance or service.

The following paragraphs provide fault code faults and symptom-based faults. If a problem is not resolved after taking the corrective actions suggested, contact a local dealer or distributor. See [Section 2.4 on page 11](#).

NOTICE

Maintaining engine oil level, keeping battery connections clean and tight, watching the fuel gauge, not overloading the generator set, etc. will prevent most shutdowns.

NOTICE

When the generator set and vehicle engine share a common fuel tank, the fuel dip tubes are usually arranged so that the generator set will run out of fuel first. Marking the generator set empty point on the fuel gauge will make it easier to tell when to stop the generator set before running it out of fuel.

6.2 Fault Codes

The generator set control contains extensive diagnostics to detect shutdown faults. Following a fault shutdown, the control indicates the fault code by flashing the numeric code on the status indicator in the control switch.

Determine the fault code as follows:

- 1 flash indicates a high engine coolant temperature.
- 2 flashes indicates a low oil pressure fault (Code 2 fault).
- 3 flashes indicates a service fault (Code 3 fault).
 1. Press **STOP/PRIME** on the control switch once to have the 2-digit service fault code flash.

The 2-digit code consists of two sets of flashes. The first set is of flashes represents the 10s digit of the code. After a brief pause, the second digit of the code flashes representing the unit digit of the code. This is followed by a long pause before repeating the flashing of the fault code.

For example, Fault Code 36 appears as: blink-blink-blink—pause—blink-blink-blink-blink-blink-blink—long pause—repeat
 2. Press **STOP/PRIME** to stop flashing the fault code.
- 4 flashes indicates that cranking exceeded 30 seconds without the engine starting (Code 4 fault).

NOTICE

Fault codes 33 and 34 are not assigned as fault codes. Be careful of interpreting Fault Codes 3 and 4 as second-level faults.

The fault code stops flashing after 5 minutes. Pressing **STOP/PRIME** 3 times within 5 seconds causes the fault code to resume flashing.

NOTICE

The last fault logged continues to flash even though the condition that caused the shutdown has been corrected.

6.2.1 Code 1 - Engine Over Temperature

Indicates that, during normal operation, the engine coolant temperature exceeded 115 °C (239 °F) for 10 seconds.

A. Check Engine Coolant Level

If coolant level is low, add coolant as necessary and repair any leaks.

B. Check for Blockages

1. If an air inlet or outlet opening on the bottom of the generator set is blocked, remove objects.
2. If dirt is fouling the radiation fins, clean dirt out.

NOTICE

Compressed air or washing with water can be helpful in removing debris from heat exchangers. Do not allow copious amounts of water to enter generator set components. A pressure washer is **NOT** advised for cleaning heat exchangers.

C. Reduce Load

Reduce the number of connected appliances, especially air conditioners and battery chargers. (Review load management in [Section 4.4.](#))

6.2.2 Code 2 - Low Oil Pressure

Indicates that the low oil pressure cutoff switch did not open.

A. Check Engine Oil Level

1. If the dipstick indicates oil is low, add oil.
2. If oil is above the full mark on dipstick, drain excess oil.

6.2.3 Code 3 - Service Check

See second-level fault code.

6.2.4 Code 4 - Over Crank

Indicates that cranking exceeded 30 seconds without engine starting.

A. Check Fuel Level

1. If fuel level is low, fill the fuel tank.

NOTICE

The generator set fuel pickup tube could be higher up in the fuel tank than the vehicle engine pickup.

2. Prime the engine fuel system by positioning the control switch to **STOP/PRIME** for 30 seconds.

B. Check Air Filter Element

Replace the air filter if dirty.

C. Replace Engine Oil

Replace engine oil with oil of proper viscosity for the ambient temperature.

NOTICE

High oil viscosity can slow down cranking speed.

D. Check Fuel Fittings

1. Tighten any fuel fitting if there is a fuel or air leak.
2. Reprime the engine fuel system by positioning the control switch to **STOP/PRIME** for 30 seconds.

E. Replace Fuel Filter

6.2.5 Code 12 - Over Voltage

Indicates the control is unable to maintain rated voltage.

A. Contact Local Dealer or Distributor

6.2.6 Code 13 - Under Voltage

Indicates the control is unable to maintain rated voltage.

A. Reduce Load

Reduce the number of connected appliances, especially air conditioners and battery chargers. (Review load management in [Section 4.4.](#))

6.2.7 Code 14 - Over Frequency

Indicates the engine governor is unable to maintain rated frequency.

A. Contact Local Dealer or Distributor

6.2.8 Code 15 - Under Frequency

Indicates the engine governor is unable to maintain rated frequency.

A. Reduce Load

Reduce the number of connected appliances, especially air conditioners and battery chargers. (Review load management in [Section 4.4.](#))

6.2.9 Code 19 - Governor Actuator

Indicates the control sensed an open or shorted circuit.

A. Contact Local Dealer or Distributor

6.2.10 Code 22 - Governor Actuator Overload

Indicates the duration of operation is near full-duty cycle beyond design limit.

A. Reduce Load

Reduce the number of connected appliances, especially air conditioners and battery chargers. (Review load management in [Section 4.4.](#))

B. Check Air Filter Element

Replace the air filter if dirty.

C. Check Exhaust System

If exhaust system is blocked, remove blockage.

6.2.11 Code 27 - Voltage Sense

Indicates the control is unable to sense output voltage.

A. Contact Local Dealer or Distributor

6.2.12 Code 29 - High Battery Voltage

Indicates that voltage across the battery system is greater than 19 Volts.

A. Check Battery

1. Check battery bank connections and reconnect if necessary so that the 12 Volt batteries serving the generator set are connected in parallel (12 Volt) rather than in series (24 Volt).
2. Select a lower battery boost charge rate.

6.2.13 Code 32 - Low Cranking Speed

Indicates that cranking speed is less than 180 RPM for more than 2 seconds.

A. Check Battery

1. Clean and tighten the positive (+) and negative (-) battery cable connections at the battery and at the generator set.
2. Recharge or replace the battery. Refer to the battery manufacturer's recommendations.

B. Replace Engine Oil

Replace engine oil with oil of proper viscosity for the ambient temperature.

NOTICE

High oil viscosity can slow down cranking speed.

6.2.14 Code 35 - Control Card Failure

Indicates that a microprocessor EEPROM error occurred during self test.

A. Contact Local Dealer or Distributor

6.2.15 Code 36 - Engine Stopped

Indicates that the engine stopped without receiving a command from the control.

A. Check Fuel Level

1. If fuel level is low, fill the fuel tank.

NOTICE

The generator set fuel pickup tube could be higher up in the fuel tank than the vehicle engine pickup.

2. Prime the engine fuel system by positioning the control switch to **STOP/PRIME** for 30 seconds.

B. Check Air Filter Element

Replace the air filter if dirty.

C. Check for Mechanical Damage

6.2.16 Code 38 - Over Current (Field Overload)

Indicates low power factor loads.

A. Reduce Load

Reduce the number of connected appliances, especially air conditioners and battery chargers. (Review load management in [Section 4.4.](#))

B. Check Appliances for Proper Operation

Have air conditioners and other appliances checked for proper operation.

6.2.17 Code 41 - Generator Rotor

Indicates control is unable to sense field or output voltage.

A. Contact Local Dealer or Distributor

6.2.18 Code 42 - Processor

Indicates that a microprocessor ROM error occurred during self test.

A. Contact Local Dealer or Distributor

6.2.19 Code 43 - Processor

Indicates that a microprocessor RAM error occurred during self test.

A. Contact Local Dealer or Distributor

6.2.20 Code 45 - Speed Sense

Indicates the control is unable to sense quadrature frequency.

A. Contact Local Dealer or Distributor

6.2.21 Code 48 - Generator Field Sense

Indicates the control is unable to sense field voltage.

A. Contact Local Dealer or Distributor

6.2.22 Code 57 - Over Prime

Indicates that priming exceeded 3 minutes.

A. Check Control Switch

Check for and remove any object that may be holding either control switch (remote or generator set) in the **STOP/PRIME** position.

6.3 Symptom Based

Diagnosis of some problems involves observing system operation.

6.3.1 Status Indicator Not Working

Indicates that there could be faulty connections or no battery voltage.

A. Check Other Control Switch

Try the generator set control switch if the remote control switch start doesn't work, and vice versa.

B. Check Battery

1. Clean and tighten the positive (+) and negative (–) battery cable connections at the battery and at the generator set.
2. Recharge or replace the battery. Refer to the battery manufacturer's recommendations.

6.3.2 Starting Batteries Run Down

Indicates problem with batteries, connections, charging system, or parasitic loads.

A. Check Battery

1. Clean and tighten the positive (+) and negative (–) battery cable connections at the battery and at the generator set.
2. Recharge or replace the battery. Refer to the battery manufacturer's recommendations.

B. Battery Charging System

Install or service a battery charging system in the vehicle.

6.3.3 Starter Engages-Disengages

Indicates cranking voltage dips below 6 Volts.

A. Use Vehicle to Start Generator Set

Run the vehicle propulsion engine while trying to start the generator set—the battery charging alternator may be able to maintain starting voltage high enough to start the generator set.

B. Check Battery

1. Clean and tighten the positive (+) and negative (–) battery cable connections at the battery and at the generator set.
2. Recharge or replace the battery. Refer to the battery manufacturer's recommendations.

C. Change Battery Cables

Increase battery cable size or run parallel cables.

6.3.4 No Power—Generator Set Running, Status Light On

Indicates line circuit breaker is **OFF**, or tripped due to short circuit or overload.

A. Check Line Circuit Breakers

1. Turn on or reset the line circuit breaker on the generator set.
2. Turn on or reset the line circuit breaker on the main distribution panel in the vehicle.

This page is intentionally blank.

This page is intentionally blank.

power.cummins.com

Copyright © 2020 Cummins Inc. All rights reserved.

Cummins, Onan, and the "C" logo are registered trademarks of Cummins Inc. and its subsidiaries.

Other company, product, or service names may be trademarks or service marks of others.

Specifications are subject to change without notice.

