



Installation Manual

Onan Generator Set for Commercial Mobile

HDKAT (Spec A–T)

HDKAU (Spec A–T)

HDKAV (Spec A–T)

Table of Contents

1. IMPORTANT SAFETY INSTRUCTIONS	1
1.1 Overview	1
1.2 Warning, Caution, and Note Styles Used in This Manual	1
1.3 General Safety Precautions	1
1.4 Automatic Generator Start Control Hazards	3
1.5 Electrical Shock and Arc Flash Can Cause Severe Personal Injury or Death	3
1.6 Generator Voltage Is Deadly	4
1.7 Engine Exhaust/Carbon Monoxide Is Deadly	4
1.8 Fuel Is Flammable and Explosive	5
1.9 Diesel Fuel Is Combustible	5
1.10 Battery Gas Is Explosive	6
1.11 Moving Parts Can Cause Severe Personal Injury or Death	6
1.12 CARB	7
2. INTRODUCTION	9
2.1 About This Manual	9
2.2 Related Literature	9
2.3 Installation Codes and Standards for Safety	10
2.4 Electromagnetic Compatibility Compliance	11
2.5 Specifications	11
2.5.1 Diesel Model Specifications	11
2.6 List of Acronyms	12
3. LOCATION, MOUNTING, AND VENTILATION	15
3.1 Location	15
3.1.1 Typical Generator Set Locations - Commercial Vehicle	16
3.1.2 Typical Generator Set Locations - High Mount	16
3.2 Mounting	17
3.2.1 Insulating Materials	17
3.2.2 Fire and Exhaust Barriers	17
3.3 Ventilation	17
3.3.1 High Mount Installations	19
4. EXHAUST SYSTEM	23
4.1 Tailpipe Installation	23
4.2 Vehicle Clearances - Class A RV	26
5. FUEL CONNECTIONS	27
5.1 Bio-diesel Fuels B5 – B20	28
6. ELECTRICAL CONNECTIONS	29
6.1 AC Power Output Connections	29
6.1.1 Wiring Methods	30

6.1.2 Connecting to Shore Power	31
6.2 Remote Control Connections.....	32
6.3 Starting Battery Connections	33
6.3.1 Battery Compartment.....	33
6.3.2 Battery Cable Sizes	34
6.3.3 Battery Cables.....	34
6.3.4 Battery Cable Connections at the Generator Set	36
6.3.5 Generator Set (Equipment) Grounding.....	36
7. INSTALLATION REVIEW AND STARTUP.....	37
7.1 Installation Review	37
7.2 Startup	37
7.3 Hot Air Recirculation Test.....	38
7.3.1 Test Method	38
7.3.2 Test Requirement.....	40
APPENDIX A. WIRING DIAGRAMS.....	41
A.0 Wiring Diagrams (0611-1236)	43
A.1 FC32 TS Wiring Diagram	44
APPENDIX B. OUTLINE DRAWINGS	45
B.0 Outline Drawing (0500-3159)	47

1 Important Safety Instructions

1.1 Overview

Thoroughly read the Operator Manual before operating the generator set. It contains important instructions that should be followed during operation and maintenance. Safe operation and top performance can only be achieved when equipment is properly operated and maintained. The owners and operators of the generator set are solely responsible for its safe operation.

Generator set operation, maintenance, and installation must comply with all applicable local, state, and federal codes and regulations. Electricity, fuel, exhaust, moving parts, and batteries present hazards which can result in severe personal injury or death. Only trained and experienced personnel with knowledge of fuels, electricity, and machinery hazards should perform generator set installation or adjustment procedures; or remove, dismantle, or dispose of the generator set.

1.2 Warning, Caution, and Note Styles Used in This Manual

The following safety styles and symbols found throughout this manual indicate potentially hazardous conditions to the operator, service personnel, or equipment.

 DANGER
<i>Indicates a hazardous situation that, if not avoided, will result in death or serious injury.</i>

 WARNING
<i>Indicates a hazardous situation that, if not avoided, could result in death or serious injury.</i>

 CAUTION
<i>Indicates a hazardous situation that, if not avoided, could result in minor or moderate injury.</i>

NOTICE
Indicates information considered important, but not hazard-related (e.g., messages relating to property damage).

1.3 General Safety Precautions

 WARNING
<i>Operation of equipment is unsafe when mentally or physically fatigued. Do not operate equipment in this condition, or after consuming any alcohol or drug.</i>

⚠ WARNING

Maintaining or installing a generator set can cause severe personal injury. Wear personal protective equipment such as safety glasses, protective gloves, hard hats, steel-toed boots, and protective clothing when working on equipment.

⚠ WARNING

Running the generator set without the cover or service door can cause severe personal injury or equipment damage. Do not operate the generator set with the cover or service doors removed.

⚠ WARNING

Coolants under pressure can cause severe scalding. Do not open a radiator or heat exchanger pressure cap while the engine is running. Let the engine cool down before removing the coolant pressure cap. Turn the cap slowly and do not open it fully until the pressure has been relieved.

⚠ WARNING

Hot metal parts can cause severe burns, Avoid contact with the radiator, turbo charger, and exhaust system.

⚠ WARNING

Starting fluids, such as ether, can cause explosion and generator set engine damage. Do not use.

⚠ WARNING

Ethylene glycol, used as engine coolant, is toxic to humans and animals. Clean up coolant spills and dispose of used antifreeze in accordance with local environmental regulations.

⚠ WARNING

Used engine oils have been identified by some state and federal agencies to cause cancer or reproductive toxicity. Do not ingest, breathe the fumes, or contact used oil when checking or changing engine oil.

⚠ CAUTION

To prevent accidental or remote starting while working on the generator set, disconnect the negative (-) battery cable at the battery using an insulated wrench.

⚠ CAUTION

Unsecured or loose fasteners can cause equipment damage. Make sure all fasteners are secure and properly torqued.

⚠ CAUTION

Oily rags and other material can cause fire and restrict cooling. Keep the generator set, drip pan, and compartment clean.

⚠ CAUTION

Accumulated grease and oil can cause overheating and engine damage presenting a potential fire hazard. Keep the generator set clean and repair any oil leaks promptly.

NOTICE

Keep multi-class ABC fire extinguishers handy. Class A fires involve ordinary combustible materials such as wood and cloth. Class B fires involve combustible and flammable liquid fuels and gaseous fuels. Class C fires involve live electrical equipment. (Refer to NFPA No. 10 in applicable region.)

1.4 Automatic Generator Start Control Hazards

⚠ WARNING

Accidental starting can cause severe personal injury or death. Turn off the AGS whenever performing maintenance or service, when the vehicle is stored between uses, is awaiting service, or is parked in a garage or other confined area.

Unexpected starting may occur if the generator set is equipped with an inverter-charger or other Automatic Generator Start (AGS) control. This may cause exposure to:

- Unexpected generator starting
- Moving parts hazards
- Electric shock
- Exhaust carbon monoxide (CO)

1.5 Electrical Shock and Arc Flash Can Cause Severe Personal Injury or Death

⚠ WARNING

Electrical shocks and arc flashes can cause severe personal injury or death. Adhere to the following guidelines:

- *Only qualified service personnel certified and authorized to work on power circuits should work on exposed energized power circuits.*
- *All relevant service material must be available for any electrical work performed by certified service personnel.*
- *Exposure to energized power circuits with potentials of 50 VAC or 75 VDC or higher poses a significant risk of electrical shock and electrical arc flash.*
- *Refer to standard NFPA 70E, or equivalent safety standards in corresponding regions, for details of the dangers involved and for safety requirements.*

1.6 Generator Voltage Is Deadly

WARNING

Improperly connected generator electrical output connections can cause equipment damage, severe personal injury, or death. Electrical connections must be made by a trained and experienced electrician in accordance with applicable codes.

WARNING

Improper installations can cause equipment damage, severe personal injury, or death. All installations must be conducted by trained and experienced personnel in accordance with the installation instructions and all applicable codes.

WARNING

Back feed to shore power can cause electrocution and damage to equipment. The generator set must not be connected to shore power or to any other source of electrical power. An approved switching device must be used to prevent interconnections.

WARNING

Live electrical equipment can cause electrocution. Use caution when working on live electrical equipment. Remove jewelry, make sure clothing and shoes are dry, stand on a dry wooden platform or rubber insulating mat, and use tools with insulated handles.

1.7 Engine Exhaust/Carbon Monoxide Is Deadly

WARNING

Substances in exhaust gases have been identified by some state and federal agencies to cause cancer or reproductive toxicity. Do not breathe in or come into contact with exhaust gases.

WARNING

Carbon monoxide is a poisonous gas. Inhalation of this gas can cause severe personal injury or death. Adhere to the following bullet points to make sure carbon monoxide is not being inhaled by occupants of the vehicle as well as others working on or around the generator set.

- *Inspect for exhaust leaks, and test and confirm that all carbon monoxide detectors are working in accordance with the manufacturer's instructions or owner's manual, prior to every startup, and after every 8 hours of running.*
- *Never occupy the vehicle while the generator set is running unless the vehicle is equipped with a working carbon monoxide detector.*
- *Never operate the generator set when the vehicle is in a confined space, such as a garage, basement, or building of any kind.*
- *Make sure the exhaust system is installed in accordance with the generator set installation manual.*
- *Never use engine cooling air for heating a working or living space compartment.*

Carbon Monoxide (CO) is odorless, colorless, tasteless, and non-irritating. It cannot be seen or smelled. Exposure, even to low levels of CO for a prolonged period can lead to asphyxiation (lack of oxygen).

Mild effects of CO poisoning include:

- headache
- dizziness
- drowsiness
- fatigue
- chest pain
- confusion

More extreme symptoms include:

- vomiting
- seizure
- loss of consciousness

1.8 Fuel Is Flammable and Explosive

WARNING

Fuel and fuel vapor is highly explosive. Adhere to the following bullets to avoid igniting fuel and fuel vapors.

- ***Do not smoke or turn electrical switches on or off where fuel fumes are present or in areas sharing ventilation with fuel tanks or equipment.***
- ***Keep flame, sparks, pilot lights, arc-producing equipment and all other sources of ignition well away from fuel lines and sources.***
- ***Fuel lines must be secured, free of leaks, and separated or shielded from electrical wiring.***

Leaks can lead to explosive accumulations of gas.

- LPG sinks when released and can accumulate inside housings and basements and other below-grade spaces.

NOTICE

Natural gas is identifiable by a rotten egg smell.

1.9 Diesel Fuel Is Combustible

WARNING

Diesel fuel is highly combustible. Adhere to the following bullets to avoid igniting fuel and fuel vapors.

- ***Do not smoke or turn electrical switches on or off where fuel fumes are present or in areas sharing ventilation with fuel tanks or equipment.***
- ***Keep flame, sparks, pilot lights, arc-producing equipment and all other sources of ignition well away from fuel lines and sources.***
- ***Fuel lines must be secured, free of leaks, and separated or shielded from electrical wiring.***

⚠ WARNING

Flammable vapor can cause a diesel engine to over speed and become difficult to stop, resulting in possible fire or explosion, and severe personnel injury or death. Do not operate a diesel-powered generator set where a flammable vapor environment can be created by fuel spill, leak, etc.

1.10 Battery Gas Is Explosive

⚠ WARNING

Battery gas is highly explosive and may cause personal injury or death if ignited. Take the proper precautions to avoid personal injury.

- *For personal safety, wear appropriate PPE when working on or around the generator set.*
- *To make sure battery gas is not ignited, do not smoke around the generator set.*
- *To reduce arcing when disconnecting or reconnecting battery cables, always disconnect the negative (-) battery cable first and reconnect it last.*

1.11 Moving Parts Can Cause Severe Personal Injury or Death

⚠ WARNING

Moving parts can cause severe personal injury or death, and hot exhaust parts can cause severe burns. Make sure all protective guards are properly in place before starting the generator set.

⚠ WARNING

Hot moving, and electrically live parts can cause severe personal injury or death. Keep children away from the generator set.

⚠ WARNING

Hot, moving, and electrically live parts can cause severe personal injury or death. Only trained and experienced personnel should make adjustments while the generator set is running.

⚠ WARNING

Moving parts can catch on loose items such as clothing or jewelry. Do not wear loose clothing or jewelry near moving parts such as PTO (power take-off) shafts, fans, belts, and pulleys.

⚠ WARNING

Moving parts can entangle appendages such as fingers. Keep the protective guards in place over fans, belts, pulleys, and other moving parts and keep hands away from all moving parts.

1.12 CARB

⚠ CAUTION

Unauthorized modifications or replacement of fuel, exhaust, air intake, or speed control system components that affect engine emissions are prohibited by law in the state of California.

The California Air Resources Board (CARB) has requirements regarding modification & repair of fuel system & exhaust components including, but not limited to, adherence to evaporative emissions requirements in mobile installations. Evaporative generator sets must be used in trailers, fifth wheel trailers, and other non-motorized vehicles where on-board gasoline fuel storage is self-contained in the trailer equipment. Completing the installation of the generator set fuel evaporative system provides compliance with the California code of regulations for small off-road equipment effective January 1, 2008 and Federal Small SI regulation effective January 1, 2011. Any questions regarding the installation or evaporative emission certification should be directed to Cummins Inc. for clarification.

This page is intentionally blank.

2 Introduction

2.1 About This Manual

This manual is a guide for the installation of the generator sets listed on the front cover. Proper installation is essential for top performance. Read through this manual before starting the installation. Leave this manual in the vehicle.

The installer must be qualified to perform installation of electrical and mechanical equipment.

This manual addresses the following aspects of the installation:

- Location, Mounting, and Ventilation
- Exhaust Connections
- Fuel Connections
- Electrical Connections
- Startup

See the Operator Manual for operation and maintenance and the Service Manual for service.

The information contained within the manual is based on information available at the time of printing. In line with Cummins Inc. policy of continuous development and improvement, information may change at any time without notice. The users should therefore make sure that before commencing any work, they have the latest information available. The latest version of this manual is available on QuickServe Online (<https://quickserve.cummins.com>).

2.2 Related Literature

Before any attempt is made to operate the generator set, the operator should take time to read all of the manuals supplied with the generator set, and to familiarize themselves with the warnings and operating procedures.

CAUTION

A generator set must be operated and maintained properly if you are to expect safe and reliable operation. The Operator manual includes a maintenance schedule and a troubleshooting guide. The Health and Safety manual must be read in conjunction with this manual for the safe operation of the generator set:

- Health and Safety Manual (0908-0110)

The relevant manuals appropriate to your generator set are also available, the documents below are in English:

- Operator Manual for Commercial Mobile Generator Set (0981-0161)
- Installation Manual for Commercial Mobile Generator Set (0981-0623)
- Service Manual for HDKAH-K (Spec A-N) and HDKAT-V (Spec A-P) (0981-0522)
- Recommended Spares List (RSL) for RV Generator Set (HDKAT) (A043T624)
- Recommended Spares List (RSL) for RV Generator Set (HDKAT, Spec E) (RSL-514)
- Recommended Spares List (RSL) for GV Generator Set (HDKAT, Spec N) (A043T630)

- Recommended Spares List (RSL) for RV Generator Set (HDKAU, Spec N) (A043T632)
- Recommended Spares List (RSL) for RV Generator Set (HDKAV, Spec N) (A043T634)
- Parts Manual for RV Generator Set (HDKAH–V, Spec A–K) (0981-0200)
- Parts Manual for Commercial Mobile Generator Set (HDKAT–V, Spec L–P) (A029S841)
- Standard Repair Times – AK Family (0900-0615)
- Service Tool Manual (A043D529)
- Failure Code Manual (F1115C)
- Engine Operation & Maintenance Manual for Kubota, 68 mm Stroke Series (0981-0514)
- Warranty Administration Manual (4021290)
- Global Commercial Warranty Statement (A028U870)

2.3 Installation Codes and Standards for Safety

CAUTION

The Commercial Generator Set Warranty applies only when the generator set is installed in a commercial or recreational vehicle. The RV Generator Set Warranty applies only when the generator set is installed in a recreational vehicle.

The installer bears sole responsibility for the selection of the appropriate generator set, for its proper installation, and for obtaining approvals from the authorities (if any) having jurisdiction over the installation. The generator sets meet the basic requirements of the Standard for Safety for Engine Generator Sets for Recreational Vehicles, ANSI/RVIA EGS-1 and are suitable for installation in accordance with:

- ANSI A1192 (NFPA No. 501C)—Recreational Vehicles
- NFPA No. 70, Article 551—Recreational Vehicles and RV Parks
- CSA Electrical Bulletin 946—Requirements for Internal Combustion Engine-Driven Electric Generators for Use in Recreational Vehicles

Federal, state, and local codes, such as the California Administrative Code—Title 25 (RV installation), might also be applicable. Installation codes and recommendations can change from time-to-time and are different in different countries, states, and municipalities. Obtain the standards listed in the table below for reference.

TABLE 1. REFERENCE CODES AND STANDARDS

Code of Federal Regulations, Title 49: Chapter III and Chapter V	Superintendent of Documents P. O. Box 371954 Pittsburgh, PA 15250-7954
NFPA 58, 70, 1192	National Fire Protection Association 470 Atlantic Avenue Boston, MA 02210
ANSI/RVIA-EGS-1	Recreational Vehicle Industry Association 14650 Lee Road Chantilly, VA 22021

California Administrative Code—Title 25, Chapter 3	State of California Documents Section P.O. Box 1015 North Highlands, CA 95660
CAN/CSA-Z240 Recreational Vehicles Bulletin 946	Canadian Standards Association Housing and Construction Materials Section 178 Rexdale Blvd. Rexdale, Ontario, Canada M9W 1R3
SAE J1231, J1508, J2044, J2599	SAE World Headquarters 400 Commonwealth Drive Warrendale, PA 15096

2.4 Electromagnetic Compatibility Compliance

Generator sets emit and receive electromagnetic (radio frequency) energy. If the generator set affects operation of nearby devices, or nearby devices affect generator set operation, increase the distance between them.

When used in countries where compliance to the EMC directive is required: This generator set has been evaluated for use in the residential, commercial, and light industrial environments.

2.5 Specifications

2.5.1 Diesel Model Specifications

TABLE 2. DIESEL MODEL SPECIFICATIONS

	HDKAT	HDKAU	HDKAV
GENERATOR SET CONTROLLER: Integrated Microprocessor Based Engine and Generator Control			
ALTERNATOR: Brushless, Exciterless, Bearingless, Permanent Magnet Alternator			
AC OUTPUT RATINGS:			
Power (@1.0 power factor)	7500 W	8000 W	6000 W
Frequency	60 Hz	60 Hz	60 Hz
Voltage	120 Volts	120 Volts	120 Volts
Number of Phases	1	1	1
Current	62.5 Amps	66.7 Amps	50.0 Amps
Line Circuit Breaker(s)	2-pole, 30 or 35 Amp	2-pole, 30 or 35 Amp	2-pole, 30 Amp
FUEL CONSUMPTION:			
No Load	.49 l/h (.13 gph)	.49 l/h (.13 gph)	.49 l/h (.13 gph)
Half Load (4000 W)	1.85 l/h (.40 gph)	1.85 l/h (.49 gph)	1.85 l/h (.49 gph)
Full Load	3.63 l/h .96 gph (.96 gph)	3.86 l/h (1.02 gph)	3.03 l/h (.80 gph)
ENGINE: 3-Cylinder In-Line, Water-Cooled, Indirect-Injection, 4-Stroke Cycle Diesel			

	HDKAT	HDKAU	HDKAV
Bore	67 mm (2.64 inch)		
Stroke	68 mm (2.68 inch)		
Displacement	719 cc (44 inch ³)		
Stroke	68 mm (2.68 inch)		
Compression Ratio	23:1		
Intake and Exhaust Valve Lash (Cold)	0.165 mm (0.0065 inch)		
Oil Capacity (with filter)*	2.6 l (3 quart)		
Cooling System Capacity**	4 l (4.2 quart)		
OPERATING SPEED RANGE:	1600 to 3200 RPM	1600 to 3300 RPM	1600 to 2900 RPM
DC SYSTEM:			
Nominal Battery Voltage	12 Volts		
Minimum Battery Capacity CCA	450 CCA*** down to -17° C (0° F) 650 CCA*** down to -29° C (-20° F)		
Maximum Regulated Charging Current	10 Amp		
Fuse F1 (control circuit)	15 Amp mini-bayonet		
Fuse F2 (starter solenoid circuit)	15 Amp mini-bayonet		
Fuse F3 (glow plug circuit)	25 Amp		
INSTALLATION:			
Weight (wet)	191 kg (420 lbs)		
Size (L x W x H)	922 x 599 x 566 mm (36.3 x 23.6 x 22.3 inch)		
* See oil filling instructions.			
** Includes coolant recovery tank.			
*** Cold Cranking Amps @ -17° C (0° F)			

2.6 List of Acronyms

TABLE 3. ACRONYM DEFINITIONS

Acronym	Definition
AC	Alternating Circuit
AGS	Automatic Generator Start
CCA	Cold Cranking Amp
CO	Carbon Monoxide
DC	Direct Current
GFCI	Grounded Fault Circuit Interrupters
LED	Light-emitting Diode

Acronym	Definition
NFPA	National Fire Protection Agency
RV	Recreational Vehicle
RVIA	RV Industry Association
SAE	Society of Automotive Engineers

TABLE 4. ACRONYMS FOR UNITS OF MEASUREMENT

Acronym	Definition
Amp	Ampere
C	Celsius
F	Fahrenheit
Hz	Hertz
kW	kilowatt
lb	Pound
M	Meters
mm	millimeters
RPM	Revolutions per Minute
V	Volts
VDC	Volts Direct Current
W	Watts

This page is intentionally blank.

3 Location, Mounting, and Ventilation

The location, mounting, and ventilation of a generator set must be such that mounting is secure, engine exhaust and fuel vapors are prevented from entering the vehicle, rain and road debris are prevented from entering the generator set, and ready access is afforded for operating the generator set and performing periodic maintenance.

3.1 Location

Typical locations for generator set installation are shown below.

- The location must provide:
 - Ready access for starting and stopping the generator set and performing all periodic maintenance.
 - Separation from sources of flammable vapors, such as batteries and fuel tanks, which the generator set could ignite.
 - Access for connecting and disconnecting fuel lines, battery cables, remote control wiring, and AC wiring.
 - Access for removing the two fuel pump mounting screws so that the generator set does not have to be removed to replace the fuel pump. See Figure 2.
 - Access from below for draining engine oil.
 - Unobstructed space below the generator set for proper cooling air flow.
- The generator set must not share a compartment or ventilation with batteries or fuel tanks. An operating generator set can ignite flammable vapors. Make sure that in the first 305 mm (12 in) of ground clearance there is at least 152.4 mm (6 in) of unobstructed space below the generator set and open on at least three sides, which is required for proper cooling air flow.
- Locate or shield the generator set cooling air openings from direct rain, road splash and debris thrown up by the road wheels.

NOTICE

Mudflaps, air ducts, and deflectors must be used to prevent road debris and tire spray from going into the generator set.

- The generator set housing is not rain proof. If the generator set is installed where snow and rain will hit the top of the generator set, a sheet metal or plastic cover should be used to prevent large amounts of water from running in the seams of the generator set housing.
- Space to mount the generator set with at least 12.7 mm (1/2 in) clearance at the top and any side of the generator set. Minimum clearances apply to any thermal or acoustic insulation with which a compartment may be lined.
- Locating a generator set more than 5 feet above the floor and at the very back of the vehicle can result in 'g' forces imparted to the generator set that causes physical damage to it as it travels down the road. Generator sets located in these areas do not have warranty coverage for damage resulting from high 'g' loads.
- Locating the generator set near the front of the coach or vehicle (directly behind or under the driver or passenger seat) creates a situation where heat from the running propulsion engine can be drawn into the generator set while stationary or moving. An alternate location should be selected for the generator set.

- The generator set and exhaust must not be within 18 inches of a LP fuel tank without the use of proper heat shielding. Refer to local codes and standards for additional information.

3.1.1 Typical Generator Set Locations - Commercial Vehicle

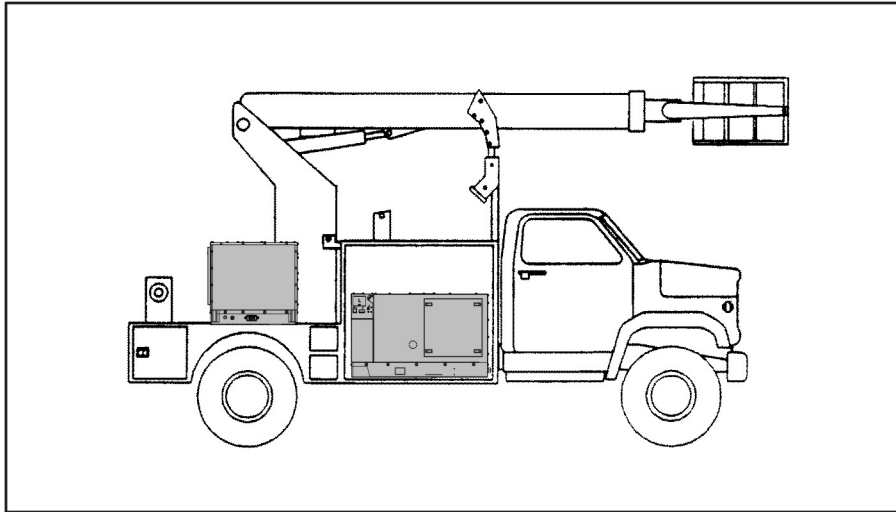

FIGURE 1. TYPICAL GENERATOR SET LOCATIONS - COMMERCIAL VEHICLE

3.1.2 Typical Generator Set Locations - High Mount

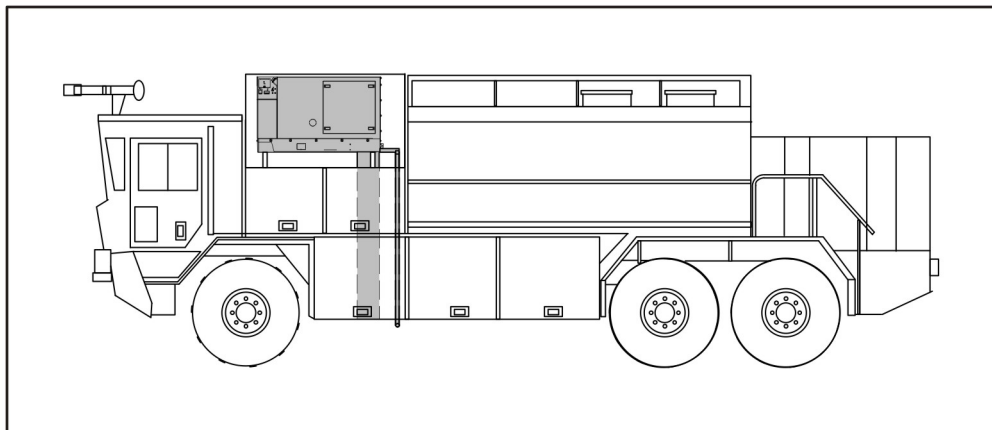

FIGURE 2. TYPICAL GENERATOR SET LOCATIONS - HIGH MOUNT

3.2 Mounting

WARNING

The generator set support structure must be designed and installed to support and restrain the dynamic weight of the generator set. Failure to do so can result in the generator set dropping onto the roadway causing property damage, severe personal injury, or death.

- Support the generator set on a structure able to resist the dynamic weight of the generator set: ± 3 g-force vertical and ± 1 g-force horizontal. See [Section 2.5 on page 11](#) for the weight of the generator set. See the outline drawings in [Appendix B on page 45](#) for mounting bolt hole locations.

TABLE 5. MOUNTING SCREWS

Quantity	Type	Torque
4	3/8-16 by 1-1/2 inch thread-forming	42 Nm (31 ft-lb)

3.2.1 Insulating Materials

Acoustic/thermal insulation and adhesive must be classified as "Self-Extinguishing" at not less than 90 °C (200 °F). Do not line the bottom of a compartment with insulation since it absorbs fuel and oil.

3.2.2 Fire and Exhaust Barriers

WARNING

Exhaust gas and fire are deadly! Install a vapor-tight and fire-resistant barrier of approved materials between the generator set and the vehicle interior. Do not duct generator set cooling air into the vehicle for heating.

- Barriers to provide vapor and fire resistance must be installed between the generator set and the interior of the vehicle if the generator set is mounted below the floor.
- If the generator set is mounted in a compartment on the floor of the vehicle, the entire compartment must be lined with vapor and fire resistive materials.
- Use approved materials (26 gauge galvanized steel or equivalent). See NFPA 1192 for details. Refer to local codes and standards for additional information.
- All seams and openings in the barriers for wiring, mounting screws, etc. must be sealed.

3.3 Ventilation

Unrestricted air flow for cooling, ventilation, and combustion is essential for proper generator set performance and service life. The air intake and discharge openings are in the bottom of the generator set.

If the generator set is installed on a floor, cut out openings in the floor that are at least as large as the openings in the generator set. The openings must line up so that the air can flow straight through the space between the generator set opening and the floor cutout opening.

NOTICE

If necessary, duct the hot discharge air through the floor to prevent recirculation inside the compartment.

Make sure frame cross members, exhaust tailpipes and other equipment do not cross underneath the air intake and discharge openings.

⚠ CAUTION

Blocking air inlet and outlet openings may restrict air flow and cause the generator set to overheat. Do not block the air inlet and outlet openings with screens, expanded metal, etc.

NOTICE

The hot air discharges away from the end of the generator set at a slight angle to reduce recirculation. This space must also be free from cross members, exhaust tailpipes, and other equipment that could deflect the discharged air back into the air intake openings.

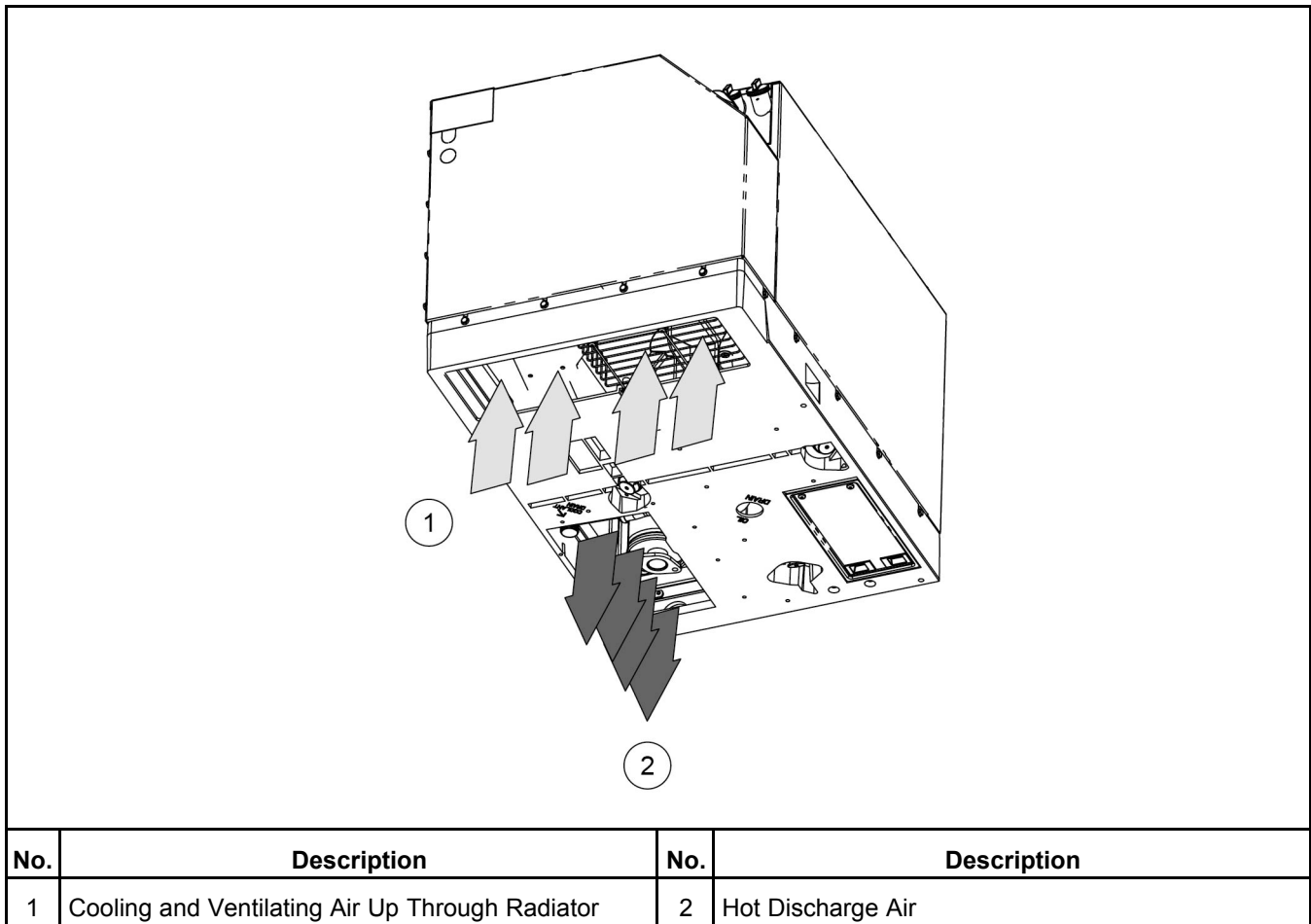

FIGURE 3. COOLING, VENTILATION, AND COMBUSTION AIR FLOWS

3.3.1 High Mount Installations

If the generator set is to be mounted high on the vehicle, consider the following:

1. The maximum fuel pump lift is 36 inches (914.4 mm). An additional fuel pump must be used for generator sets mounted more than 36 inches (914.4 mm) above the fuel source. Auxiliary Fuel Pump Kit 541-0530 is available from Cummins.
2. Provide 2.5 inches (63.5 mm) minimum clearance to the sides and rear of the generator set, and 0.25 inch (6.35 mm) clearance to the front of the generator set. This area provides the generator set's intake air for cooling.
3. Risers must be fabricated to raise and support the generator set above the compartment floor. This area provides the generator set's intake air for cooling. At these clearances, minimum compartment dimensions are:
 - Width: 24.98 inches (634.5 mm)
 - Width: 24.98 inches (634.5 mm)
4. Ducting must be fabricated to exhaust hot air from the generator set. Foam or gasket material must be used between the duct and the base of the set to prevent recirculating of exhausted hot air.
5. The exhaust tailpipe must be routed down and underneath the vehicle and terminate at least 1 inch (25.4 mm) beyond the perimeter of the vehicle. The tail pipe may be routed inside the hot exhaust duct, but not through the interior of the vehicle. The tail pipe must be visible and accessible along its entire length for inspection and replacement.

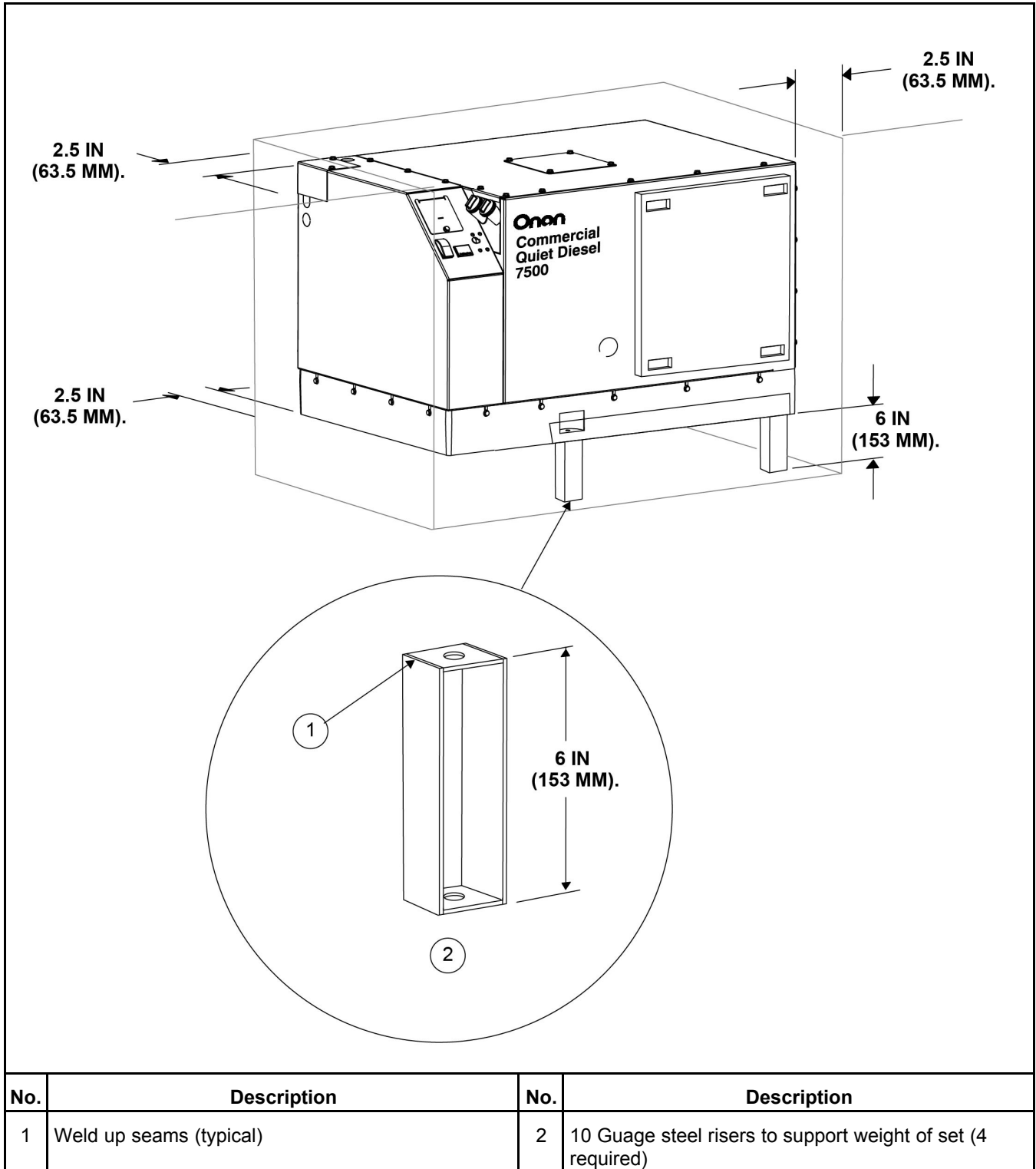
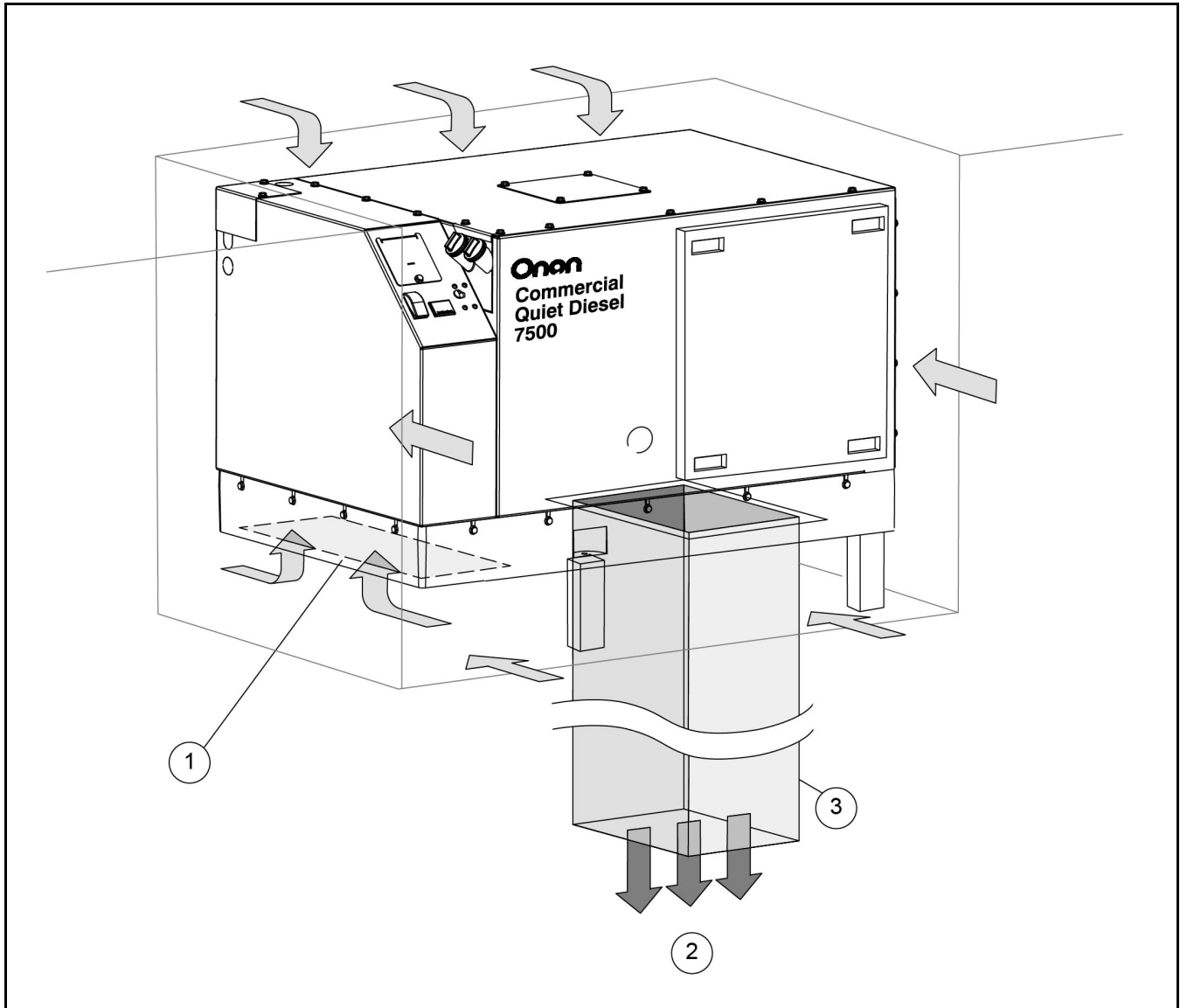

FIGURE 4. HIGH MOUNT INSTALLATION



No.	Description	No.	Description
1	Air intake area	3	Minimum Duct size 13.25 X 7.5 inches (336.6 to 191 mm) (Length - as needed up to 60 inches {1524 mm})
2	Hot exhaust area		

Keep exhausted air away from intake air.
 Use foam/gasket material to seal duct to base of set.

FIGURE 5. INTAKE AIR - EXHAUST AIR DUCTING

This page is intentionally blank.

4 Exhaust System

WARNING

Exhaust gas is deadly. Modifying the exhaust system may let poisonous exhaust gases enter the vehicle interior. Use only Onan replacement parts to service the exhaust system. Unauthorized modifications will void the Onan warranty. Liability for injury or damages due to unauthorized modifications becomes the responsibility of the person making the modification.

The generator set exhaust system must be gas-tight and prevent entry of exhaust gases into the vehicle interior.

Failure to provide and maintain an approved spark arresting exhaust system can be a violation of the law. Liability for damage, injury, and warranty expense due to the modification of the exhaust system, or use of unapproved parts is the responsibility of the person performing the modification. Contact an Onan dealer for approved exhaust system parts.

4.1 Tailpipe Installation

The muffler is mounted inside the generator set and has a flange to which the tailpipe adapter (available from Cummins) is bolted.

There are side and rear openings for tailpipe connections. Use the appropriate straight or elbowed adapter.

WARNING

Flexible pipe is not gas tight or durable and can cause exhaust gas leaks. Do not use flexible pipe for tailpipe.

1. Use 18-gauge 1-3/8 inch I.D. aluminized steel tubing or material of equivalent heat and corrosion resistance for the tailpipe.
2. Secure the tailpipe or adapter flange to the muffler flange with a gasket and 2 5/16-18 bolts.
3. Use U-bolt muffler clamps to connect sections of tailpipe. Overlapping pipe should be slotted.
4. Use automotive-type tailpipe hangers every 600mm to 900mm (2 to 3 ft). Attach the hangers to steel framework, not wood or other combustible material.
5. Do not terminate the tailpipe underneath the vehicle. Extend it a minimum of 25mm (1 in) beyond the perimeter of the vehicle. Support the end of the tailpipe such that it cannot be pushed in and up under the skirt of the vehicle.

NOTICE

Do not terminate the tailpipe under a slide-out room unless the bottom of the slide-out, including skirts and moldings, is at least 900mm (3 ft) above the end of the tailpipe.

6. Do not route the tailpipe such that it will interfere with draining engine oil or coolant or restrict the air inlet/outlet.
7. Do not route the tailpipe closer than 76mm (3 in) to combustible material (wood, felt, cotton, organic fibers, etc.) unless it is insulated or shielded. The temperature rise (above ambient) on adjacent combustible material must not exceed 65 °C (117 °F).

- 8. Do not route the tailpipe near fuel lines or fuel tanks or terminate it below or near a fuel fill opening.
- 9. Do not terminate the tailpipe such that it is closer than 153mm (6 in) to any opening, such as a door, window, vent, or unsealed compartment into the vehicle interior.
- 10. Do not interconnect generator set and vehicle engine exhaust system.

⚠ CAUTION

Excessive back pressure can cause loss of performance and engine damage.

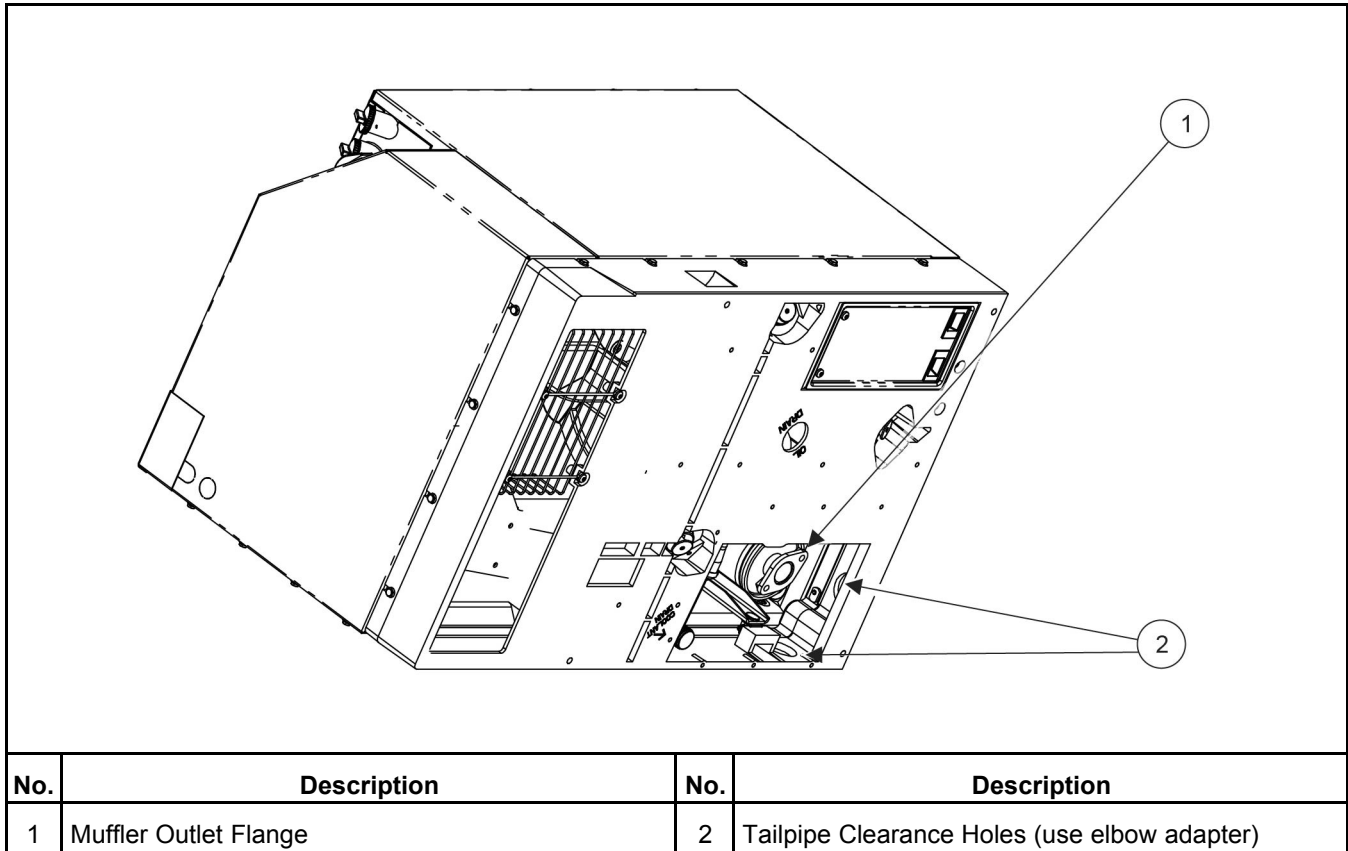

FIGURE 6. TAILPIPE INSTALLATION

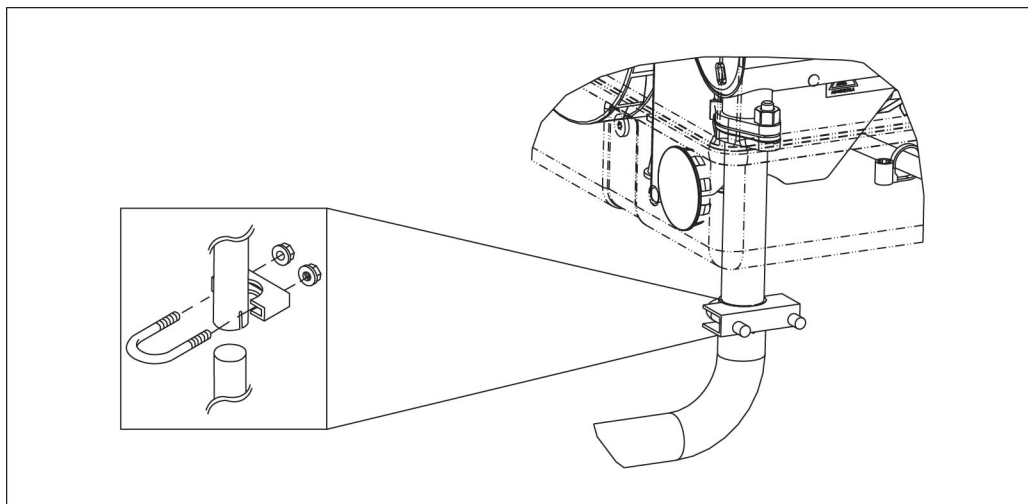
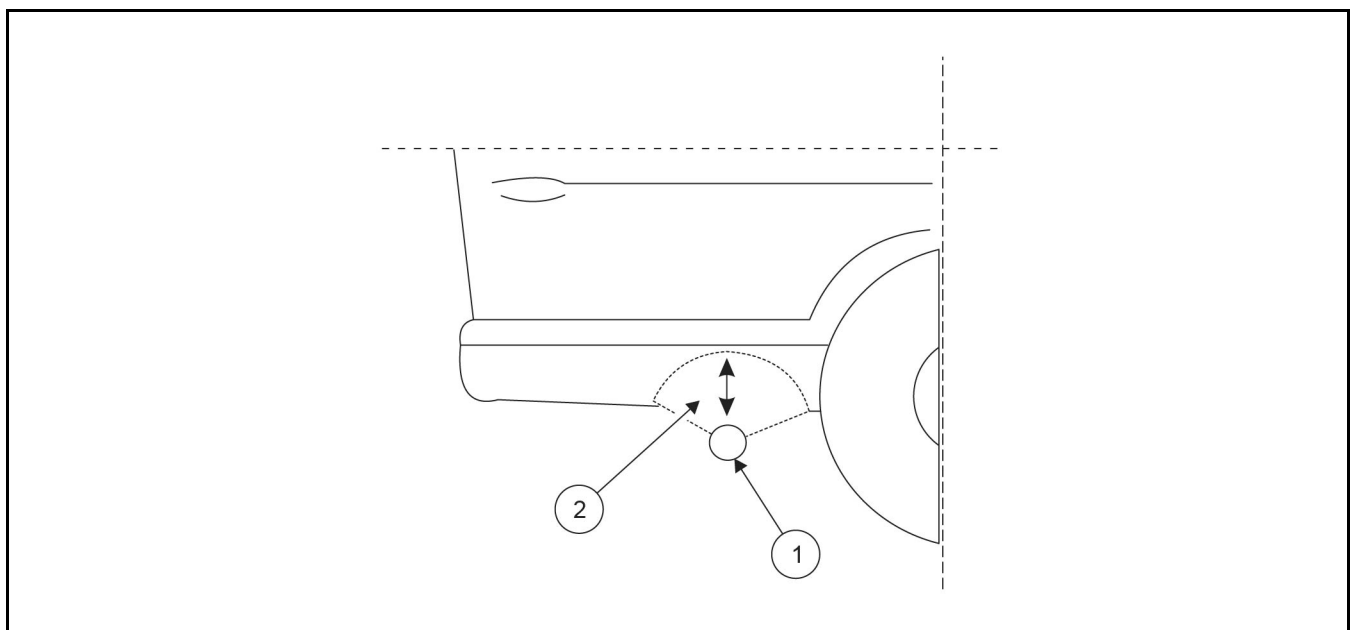

FIGURE 7. EXHAUST TAILPIPE CONNECTIONS



No.	Description	No.	Description
1	Tailpipe	2	153mm (6 in)

No opening into the vehicle interior may be closer than 153mm (6 in) to the end of the tail pipe (within area 2, identified in this image).

FIGURE 8. MINIMUM DISTANCES TO OPENINGS

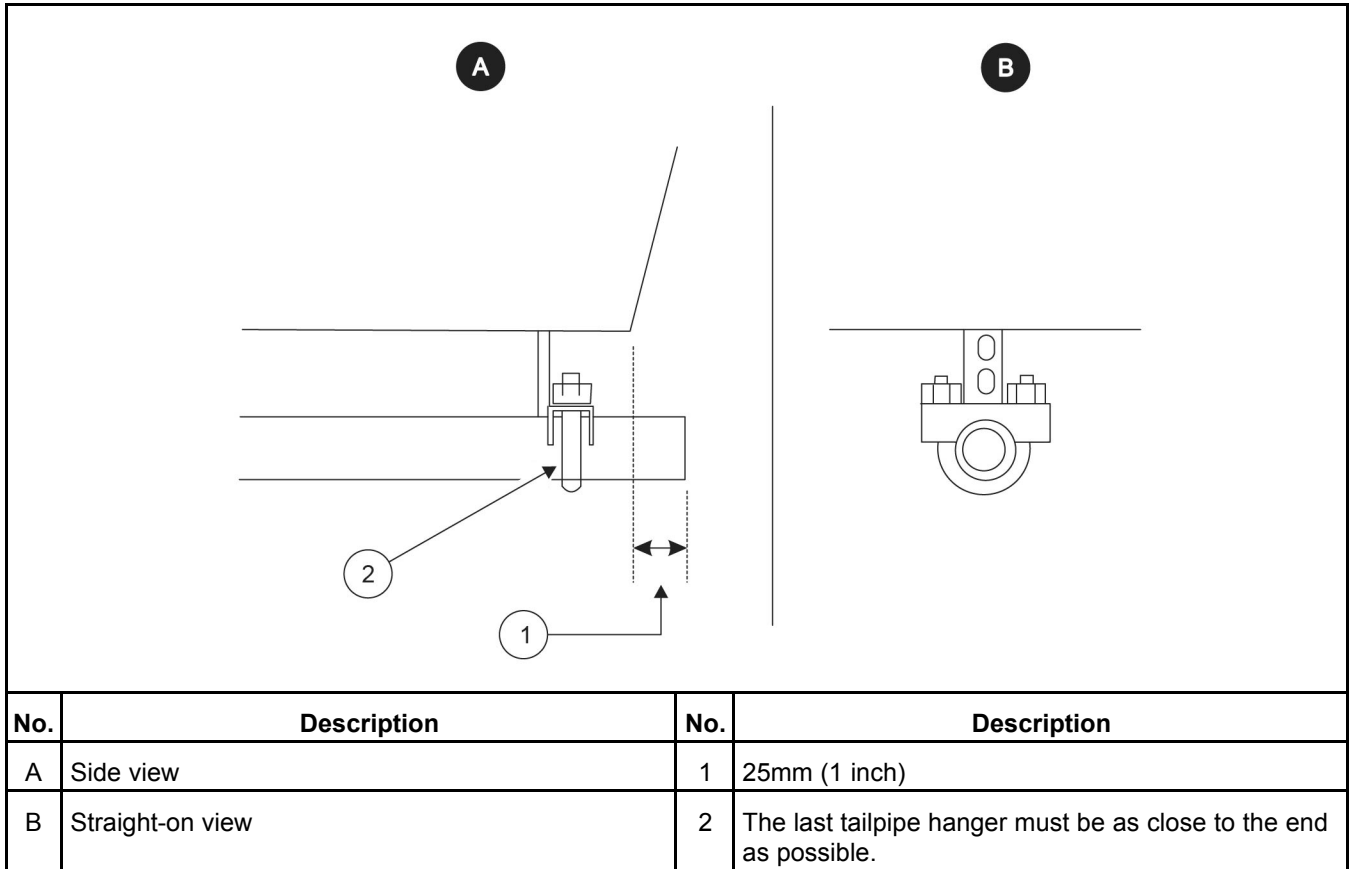

FIGURE 9. TERMINATING THE EXHAUST TAILPIPE

4.2 Vehicle Clearances - Class A RV

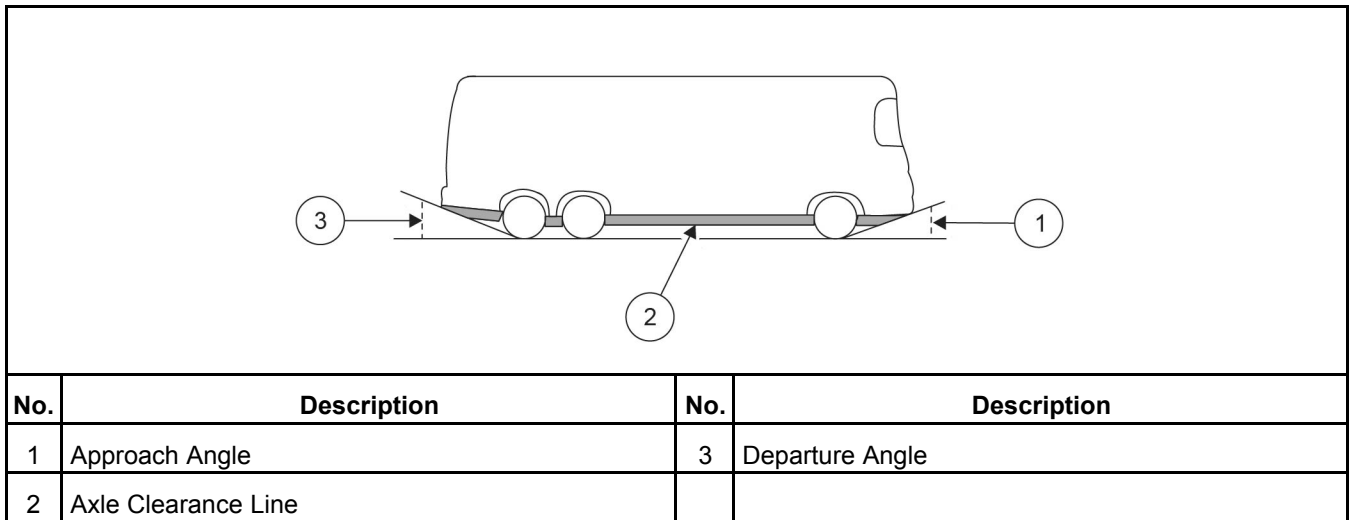

FIGURE 10. VEHICLE CLEARANCES - CLASS A RV

5 Fuel Connections

See the Operator Manual for recommended fuels and [Section 2.5 on page 11](#) for fuel consumption.

⚠ CAUTION

Unauthorized modifications or replacement of fuel, exhaust, air intake, or speed control system components that affect engine emissions are prohibited by law in California.

⚠ CAUTION

Either or both engines could starve for fuel if the generator set and vehicle engine fuel lines are interconnected. Always use separate fuel lines or a separate fuel tank for the generator set.

Do not interconnect generator set and vehicle engine fuel lines. Follow the vehicle chassis manufacturer's instructions when making connections to the vehicle engine fuel tank.

To prevent the generator set from running the vehicle out of fuel, do not extend the generator set fuel pickup tube down into the fuel tank as far as the pickup tube for the vehicle engine.

- Fuel lines (supply and return) must have at least 6.4mm (0.25 in) I.D.
- Run the fuel line at or above the top of the fuel tank to reduce the risk of siphoning fuel out of the tank if the line should break.
- The maximum fuel pump lift is 0.9m (36 in).
- Route fuel lines away from electrical wiring and hot engine exhaust components.
- Fuel lines should be accessible for inspection and replacement, protected from damage, and secured to prevent kinking, contact with sharp edges, and chafing due to vibration.

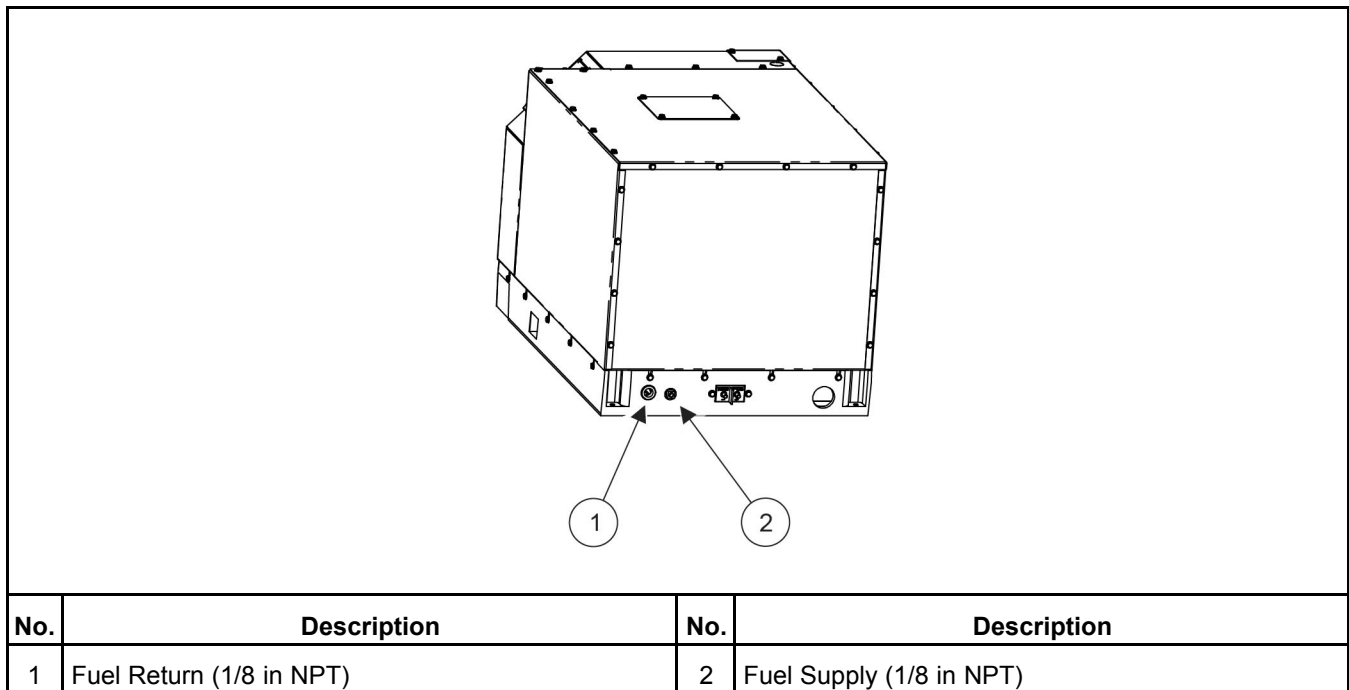

FIGURE 11. FUEL CONNECTIONS

5.1 Bio-diesel Fuels B5 – B20

For bio-diesel blends above B5 and up to B20, Cummins requires that the fuel meet the specifications outlined in ASTM D7467. The bio-diesel component of this fuel blend must meet ASTM D6751 or EN14214, and the petroleum diesel component must meet ASTM D975.

CAUTION

Market applications contain properties that can affect engine operating characteristics. It is highly recommended that use of these bio-diesel fuel blends be avoided or exercised with extra care. Use standard fuels in applications that experience seasonal usage, storage for periods exceeding 90 days, and extreme temperatures or humidity.

The following installation requirements must be met:

- Natural rubber, butyl rubber, and some types of nitrile rubber may be partially susceptible to degradation when exposed to bio-diesel. Also, copper, bronze, brass, tin, lead, and zinc can cause deposit formations. The use of these materials and coatings should be avoided for vehicle fuel tanks and fuel lines. Always check with components manufacturers to confirm compatibility with B20.
- Fuel tanks must be made from the following materials:
 - Aluminum
 - Steel
 - Fluorinated polyethylene
 - Fluorinated polypropylene
 - Teflon (PTFE)
- Verify the vehicle propulsion engine is capable of using B20 when sharing the same fuel tank with the generator set.
- A bio-diesel compatible fuel water separator is required. Because water separators do not work as well with bio-diesel as they do petroleum-based diesel, it is very important to prevent water from entering the fuel supply. Place the fuel water separator in a location that is accessible for service, as close to the generator set as possible.

Bio-diesel blends have higher pour and cloud points than standard diesel fuels. Generator set locations far from the fuel tank, combined with low fuel flow rates can make the generator set fuel system susceptible to fuel starvation related to gelling in cold weather (below -5°C (23°F)). In addition to electric or coolant tank heaters, consideration to routing and possible heating or insulation of fuel lines to the generator set may be needed.

Bio-diesel blends can oxidize more quickly than standard diesel fuels and require more fuel filter service intervals. Also, shorter fuel storage life in tanks is likely.

If bio-diesel fuel is used for seasonal applications (stored more than 90 days), the generator must be purged before storage by running the engine on pure diesel fuel meeting ASTM D975 for a minimum of 30 minutes.

For emergency standby RV or seasonal commercial use where low annual hours are accumulated, bio-diesel is not recommended, only petroleum diesel should be used. Low fuel usage and the critical start nature of an emergency stand-by generator set make using bio-diesel impractical.

6 Electrical Connections

⚠ WARNING

HAZARDOUS VOLTAGE! *Touching uninsulated live parts inside the generator set and connected equipment can result in severe personal injury or death. For your protection, stand on a dry wooden platform or rubber insulating mat, make sure your clothing and shoes are dry, remove jewelry from your hands, and use tools with insulated handles. Secure protective covers when completing installation.*

⚠ WARNING

IMPROPER WIRING can cause fire or electric shock resulting in severe personal injury or death.

⚠ WARNING

Accidental starting of the generator set can cause severe personal injury or death. Do not connect the starting battery until instructed in [Chapter 7 on page 37](#).

6.1 AC Power Output Connections

The generator set is equipped with a terminal block and conduit connector knockouts for AC power output connections.

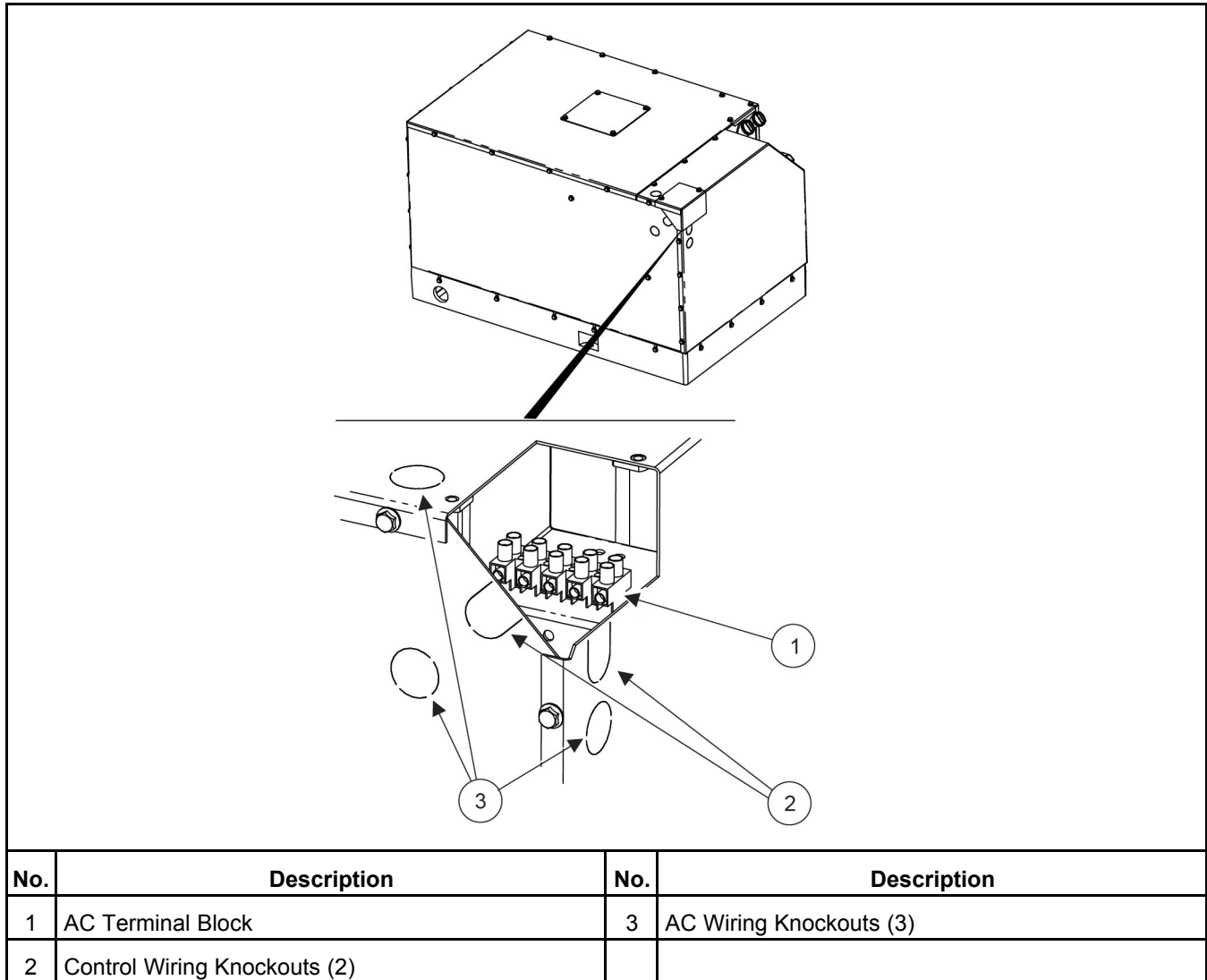

FIGURE 12. AC OUTPUT CONDUIT

6.1.1 Wiring Methods

Follow the National Electrical Code, especially noting the following:

1. Have a qualified electrician supervise and inspect the installation of all AC wiring.
2. Secure only one lead at each AC output terminal. The terminals are suitable for wire sizes up to No. 6 AWG.
3. Install vibration-proof switches and controls that won't open and close circuits when the vehicle is in motion.
4. User rain-tight conduit, conduit connectors, and junction boxes for all exterior wiring.
5. Provide ground fault circuit interrupters (GFCIs) for all convenience power receptacles.
6. Route AC wiring, remote control wiring, and fuel lines separately.
7. Seal all conduit openings into the vehicle interior to keep out exhaust gas. Apply silicone rubber or an equivalent type of sealant inside and outside each conduit connector. (Flexible conduit is not vapor tight and will allow exhaust gas to enter along the wires if not sealed.)

⚠ WARNING

Faulty grounding can lead to fire and electrocution, resulting in severe personal injury or death. Grounding must be in accordance with applicable codes.

8. Connect the grounding terminal TB2-4 in accordance with applicable codes.

6.1.2 Connecting to Shore Power

⚠ WARNING

Electrocution
Incorrect connection of the generator set and shore power can cause severe personal injury and equipment damage.
Use an approved switching device to prevent interconnections.

A vehicle with provisions for connecting to utility power must have an approved device to keep the generator set and utility from being interconnected.

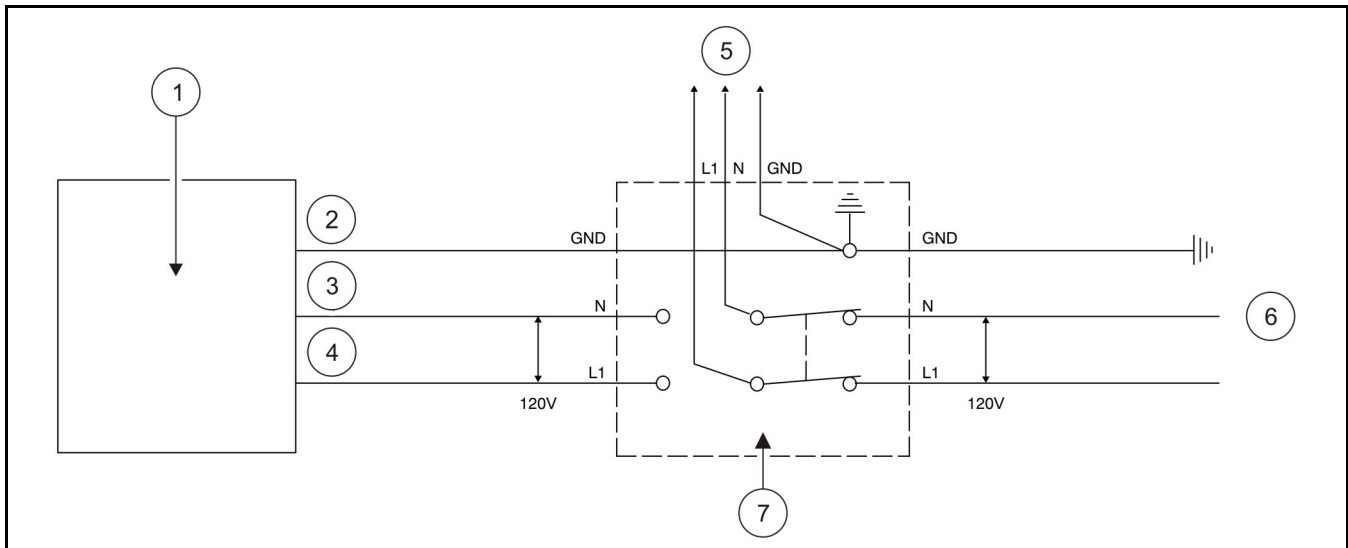

No.	Description	No.	Description
1	Generator Set	5	To Vehicle AC Distribution Panel
2	Green	6	Utility Power
3	White	7	Transfer switch
4	Black		

* DO NOT SECURE MORE THAN ONE CONDUCTOR AT ANY TERMINAL ON TB2.

** This circuit has a 30 or 35 Amp circuit breaker. Wiring and equipment must be sized and protected accordingly.

FIGURE 13. TYPICAL CONNECTIONS WITH TRANSFER SWITCH AND UTILITY

6.2 Remote Control Connections

Leads for connection to a remote control panel are terminated in a 10-pin sealed connector and are stowed inside the AC terminal enclosure when the generator set leaves the factory.

To make connections to a remote control panel:

1. Remove the AC terminal access cover and remove one of the control wiring knockouts.
2. Pull out the remote control connector plug, fit the bushing around the connector leads into the knockout slot, and secure the access cover.
3. Snap the connector plug and harness receptacle together.
4. If the harness does not have a plug for connection at the control panel, use solder-type butt connectors and heat-shrink insulation tubing to connect to the wiring from the remote control panel.

Use insulated 18 AWG copper conductors for the wiring.

5. Route control leads separately from AC power leads to reduce the possibility of erratic operation due to false induced signals.
6. Seal the opening where the leads enter the vehicle interior with silicone rubber or equivalent sealant to keep out exhaust gas.

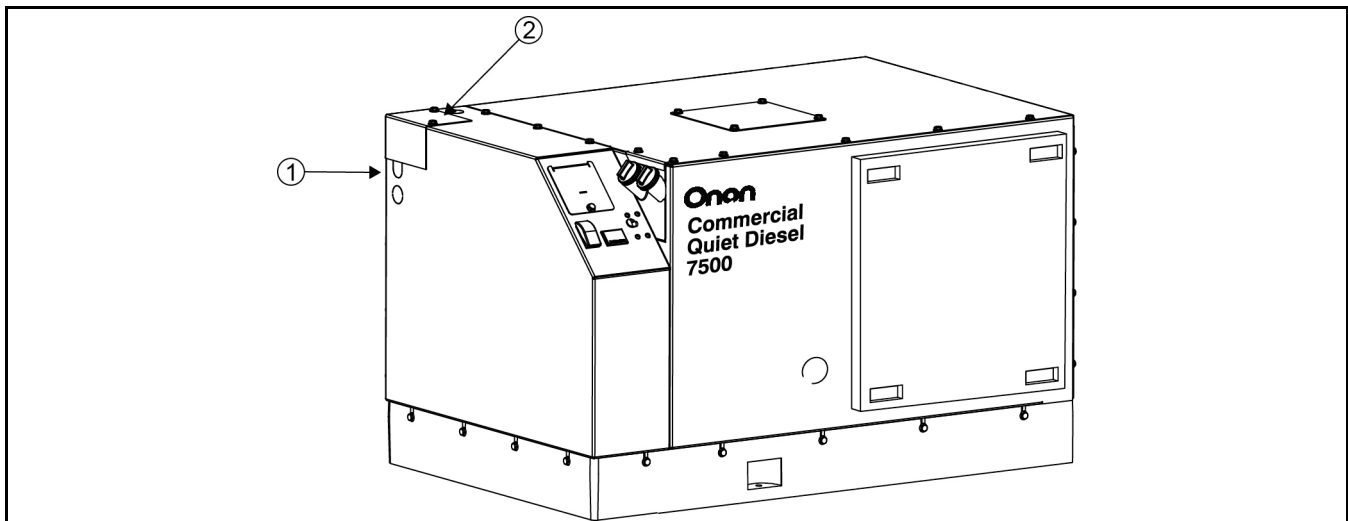

No.	Description	No.	Description
1	Control Wiring Knockouts (Located on rear)	2	Remote Control Connector Access

FIGURE 14.

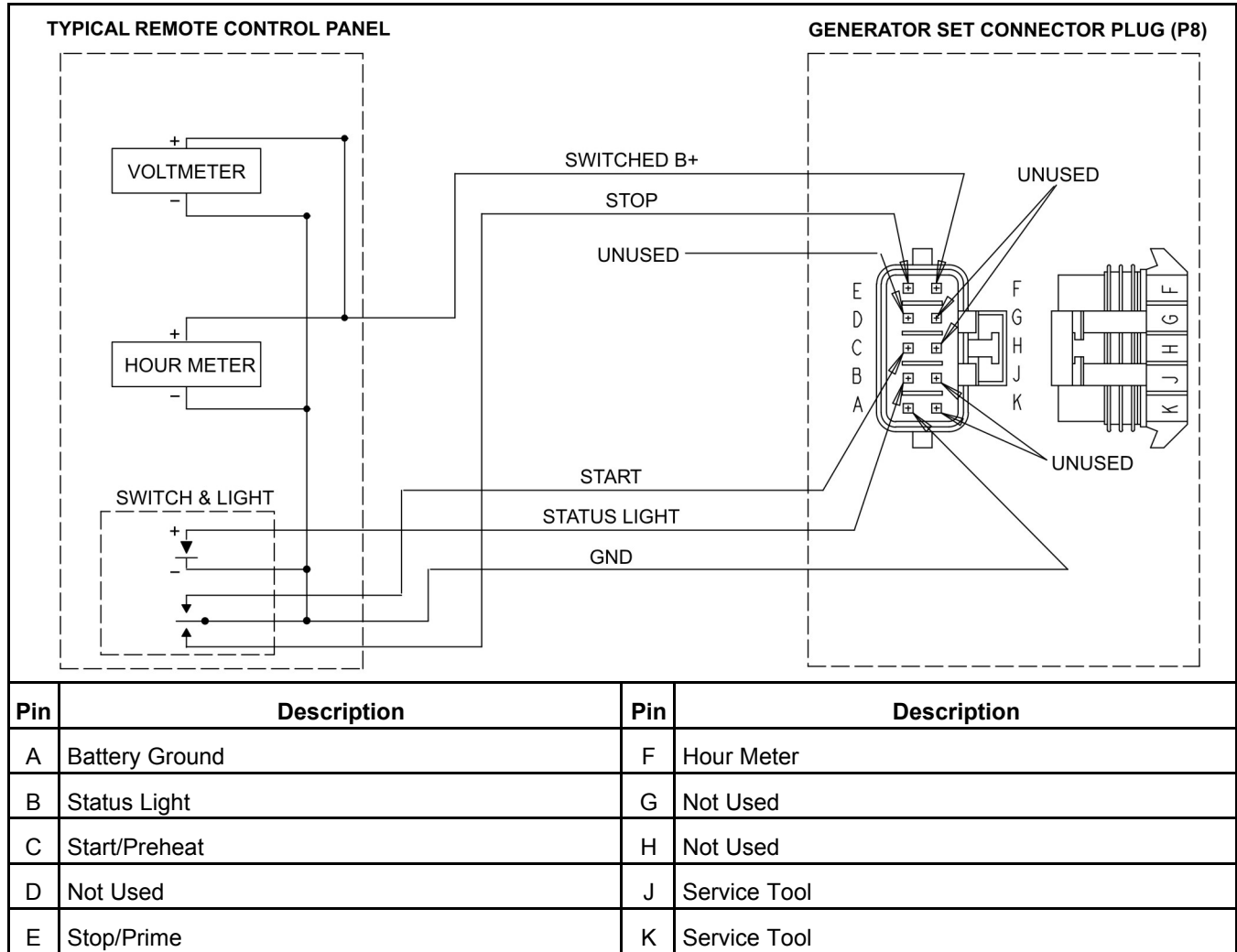

FIGURE 15. REMOTE CONTROL CONNECTOR PLUG AND TYPICAL CONNECTIONS

6.3 Starting Battery Connections

⚠ WARNING

Accidental starting of the generator set can cause severe personal injury or death. Do not connect the starting battery until instructed in [Chapter 7 on page 37](#).

The generator set has a 12 VDC, negative-ground engine control and cranking system. See [Section 2.5 on page 11](#) for the requirements for cranking batteries.

6.3.1 Battery Compartment

⚠ WARNING

Arcing can ignite the explosive hydrogen gas given off by the battery, causing severe personal injury. The battery compartment must be ventilated and must isolate the battery from spark-producing equipment.

Batteries must be mounted in a separate compartment from that of the generator set and away from spark-producing equipment. A compartment must have openings of at least 11 cm² (1.7 in²) at the top and bottom for ventilation of battery gasses. It should be mounted such that spills and leaks will not drip acid on fuel lines, wiring, and other equipment that could be damaged.

- Stand-alone applications will require a starting battery and a battery charger.
- RVs often connect "house" batteries to the generator set. All RVs should be equipped with a battery charger to charge the batteries.

6.3.2 Battery Cable Sizes

TABLE 6. BATTERY CABLE SIZES FOR TEMPERATURES DOWN TO -29 °C (-20 °F)

Total Cable Length ¹	Cable Size
0 to 7.6 m (0 to 25 ft)	0 AWG
8 to 21.3 m (26 to 70 ft)	00 AWG
22.25 to 27.4 m (73 to 90 ft)	000 AWG
1. Battery cable lengths are total lengths from battery to the generator back to the battery, based on 300 Amp cranking amperage.	

6.3.3 Battery Cables

Size battery cables according to the Battery Cable Sizes table. The current path between the generator set and the negative (-) battery terminal must also be able to carry full cranking current without causing excessive voltage drop. It is highly recommended that a full-length cable be used to connect the generator set to the negative (-) battery terminal. Note also that codes may require bonding conductors from the generator set and the battery to the vehicle frame.

If a vehicle frame is used as the path between the negative (-) battery terminal and the generator set, all frame members in the path of battery cranking currents must have substantial cross sections. The electrical resistance of riveted or bolted frame joints must also be carefully considered, especially if the joints will be exposed to corrosive conditions. A cable must be used to connect the frame to the designated negative (-) terminal on the generator set.

NOTICE

The generator set mounting bolts are not considered an adequate means of bonding the generator set to the vehicle frame, either for the purpose of carrying cranking currents or for complying with requirements for generator set/system grounding.

Coat all battery cable connections with a battery terminal oxidation inhibitor.

⚠ WARNING

Routing battery cables with fuel lines can lead to fire and severe personal injury or death. Keep battery cables away from fuel lines.

Route battery cables away from fuel lines and hot engine exhaust components. Battery cables should be accessible for inspection and replacement, protected from damage and secured to prevent chafing due to vibration.

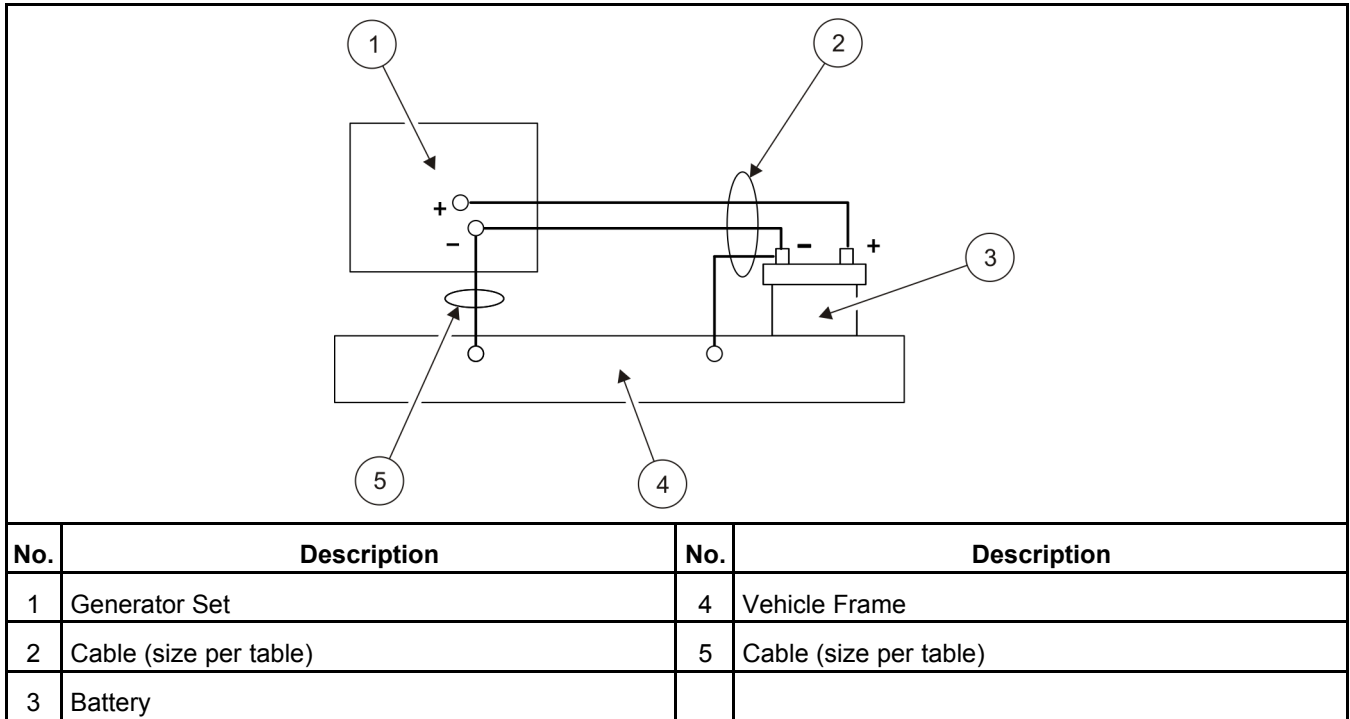

FIGURE 16. FULL-LENGTH CABLE FROM BATTERY NEGATIVE (-) TERMINAL

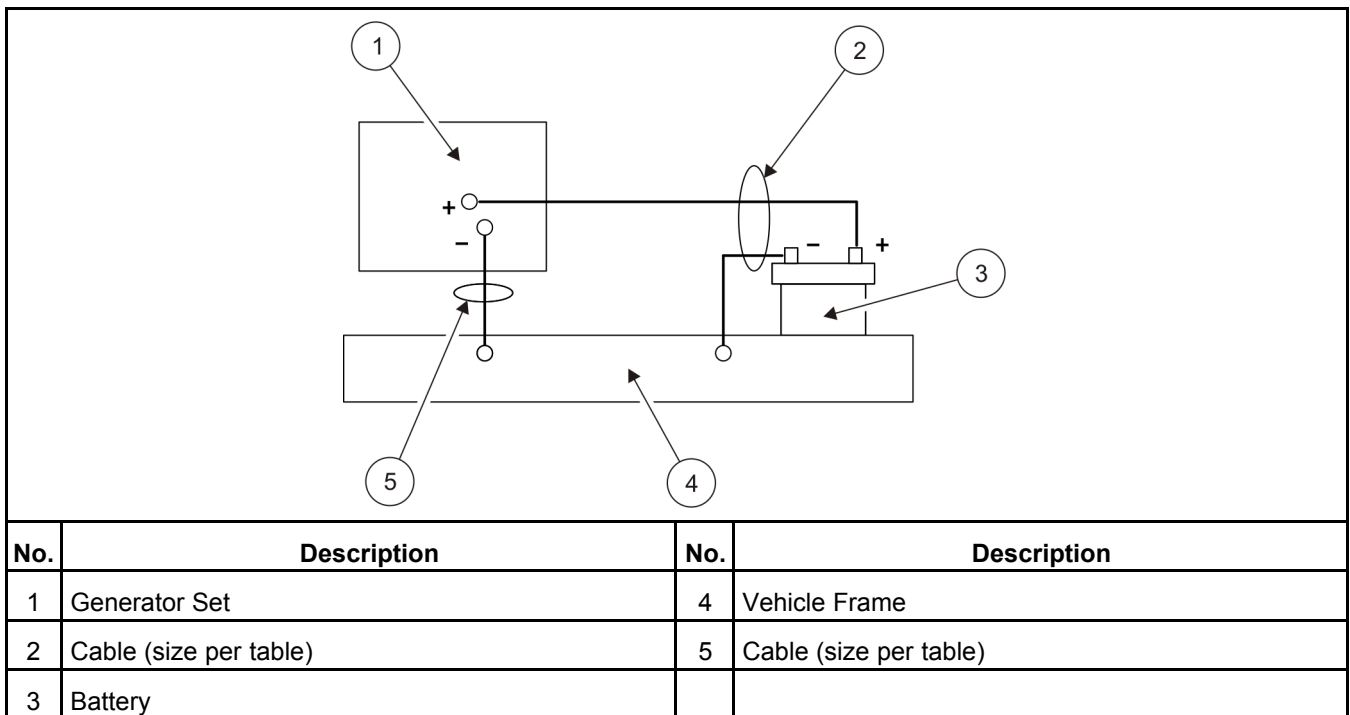

FIGURE 17. VEHICLE FRAME AS PATH FROM BATTERY NEGATIVE (-) TERMINAL

6.3.4 Battery Cable Connections at the Generator Set

Terminate the battery cables with ring terminals sized for 5/16 inch screws and connect them to the generator set. Secure the insulating boot on the positive (+) terminal and tie it to the battery cable with the tie-wrap in the bag with the manuals.

Torque the positive (+) cable terminal to 10 Nm (7.5 ft-lbs).

Torque the negative (-) cable terminal to 10 Nm (7.5 ft-lbs).

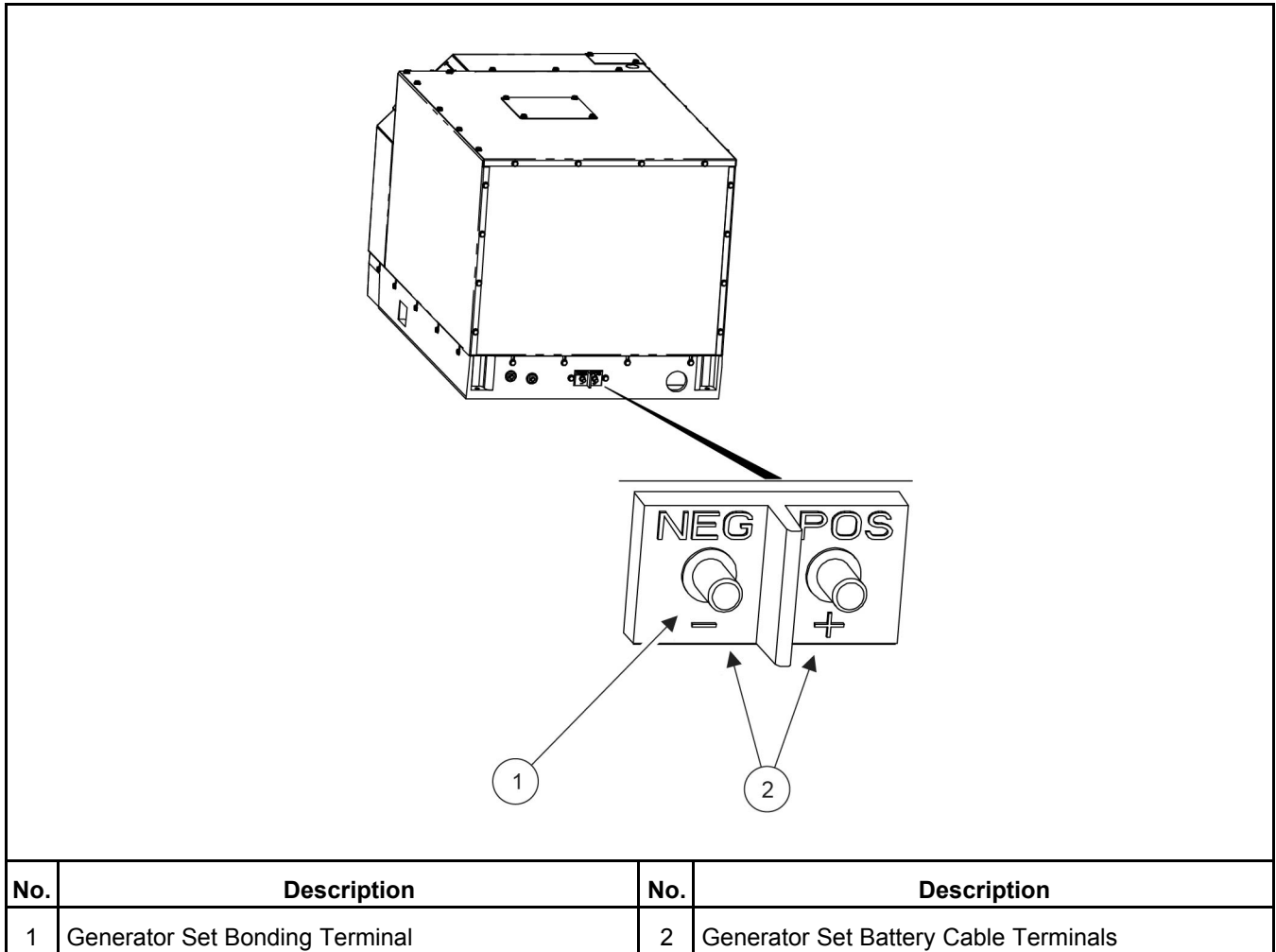

FIGURE 18. BATTERY CABLE CONNECTIONS

6.3.5 Generator Set (Equipment) Grounding

The negative (-) battery cable terminal shown is also the grounding terminal to ground the generator set to the vehicle chassis. If the grounding cable is also going to carry starter motor current, it must be sized the same as the battery cables.

7 Installation Review and Startup

7.1 Installation Review

Before starting the generator set, inspect the installation and check (✓) each of the following questions if it can be answered "YES." If an item cannot be checked, provision must be made to satisfy the requirement.

- Is the control panel on the generator set easily accessible for starting and stopping the generator set and resetting the circuit breaker?
- Is there easy access for checking and adding engine coolant?
- Is the generator set securely bolted in place?
- Are all specified clearances provided?
- Are the cooling and combustion air inlet and outlet openings free of obstructions?
- Is there access for draining engine oil?
- Is there access for draining engine coolant?
- Is there access for changing the air filter, checking oil level, and adding oil?
- Is there access (through the top service access cover) for cleaning out the spark-arrest muffler?
- Are all tail pipe connections tight and all hangers and support straps secure?
- Does the tailpipe terminate at least 25 mm (1 in) beyond the perimeter of the vehicle and at least 153 mm (6 in) away from any opening into the vehicle?
- Is the tailpipe not under a slide-out room or near a fuel fill opening?
- Is the generator set located outside the vehicle interior or separated by approved vapor-tight and fire-resistive materials?
- Are all openings into the vehicle, such as for AC wiring, sealed to keep out engine exhaust? Are AC conduit connectors sealed inside and outside?
- Have all AC connections been inspected and approved?
- Has a properly sized battery been installed in a ventilated compartment isolated from the generator set?
- Have properly sized battery cables been installed and secured at sufficient intervals to prevent chaffing and contact with sharp edges, fuel lines, and hot exhaust parts?
- Is the negative (–) battery terminal properly grounded to the vehicle chassis?
- Are all fuel connections tight?
- Has the fuel line(s) been secured at sufficiently close intervals to prevent chaffing and contact with sharp edges, electrical wiring, and hot exhaust parts?

7.2 Startup

 **WARNING**

Batteries give off explosive gases that can cause severe personal injury. Do not smoke near batteries. Keep flames, sparks, pilot lights, switches, arc-producing equipment, and all other ignition sources away.

When all the items on the Installation Review check list have been checked, connect the battery cables to the battery, positive (+) cable first.

Read the Operator Manual and perform the maintenance and pre-start checks as instructed. The generator set is shipped from the factory with the proper level of engine oil and coolant, but should be checked before starting the generator set.

⚠ WARNING

EXHAUST GAS IS DEADLY! Do not operate the generator set when the vehicle is indoors or where exhaust can accumulate.

Start and operate the generator set, following all the instructions and safety precautions in the Operator Manual.

Check for fuel, coolant, and exhaust leaks, and unusual noises while the generator set is running under full and intermediate loads. Do not place the generator set in service until all fuel and exhaust leaks have been fixed and operation is satisfactory.

7.3 Hot Air Recirculation Test

⚠ WARNING

This product incorporates a catalyst exhaust system which leads to higher exhaust gas temperatures and higher cooling air outlet temperatures. The installer must review and follow all guidelines for the installation. Care must be taken to make sure that all installation requirements in this entire manual are met.

A representative installation of the generator set must be tested to determine that the generator set will not overheat due to recirculation of hot air back into the generator set.

7.3.1 Test Method

⚠ WARNING

EXHAUST GAS IS DEADLY! Do not operate the generator set when the vehicle is parked indoors or where exhaust can accumulate.

1. Complete a representative installation.
2. Conduct the test in a well ventilated space in which carbon monoxide cannot accumulate, but is protected from cross drafts that could affect temperature measurements.
3. Connect a large, constant, load to the generator set. If a load bank is available, connect at least 3/4 full load. If not, connect and run the largest combination of constant loads that can be kept on during the test without tripping the generator set circuit breaker. For example, a combination of air conditioners, hair dryers, and lights. Make sure the air conditioners stay on and do not cycle during the test.
4. Measure temperatures with thermocouples not heavier than 0.21mm² (24 AWG).
 - a. Measure generator set intake air temperature with one or two thermocouples tied about 25.4mm (1 in) away from the face of the radiator in the intake air opening. Make sure the thermocouples don't touch the radiator.

- b. Measure ambient air temperature with a shielded thermocouple within 1.2M (4 ft) of the generator set and approximately the same height. Make sure the thermocouple will not be affected by warm air discharged from the generator set or by sunlight. Use 50.8mm (2 in) diameter white PVC piping at least 152.4mm (6 in) long as a thermocouple shield.
- 5. Close all compartment doors and run the generator set for at least 90 minutes. Record temperatures at 15 minute intervals. The following table illustrates how the data can be arranged for recording and analysis.

TABLE 7. TEMPERATURE DATA

THERMOCOUPLE LOCATION	TEMPERATURE °C (°F)						
	Time of Reading						
	0	15	30	45	60	75	90
Intake Air Temperature							
Ambient Air Temperature							
Temperature Difference (Intake - Ambient)							

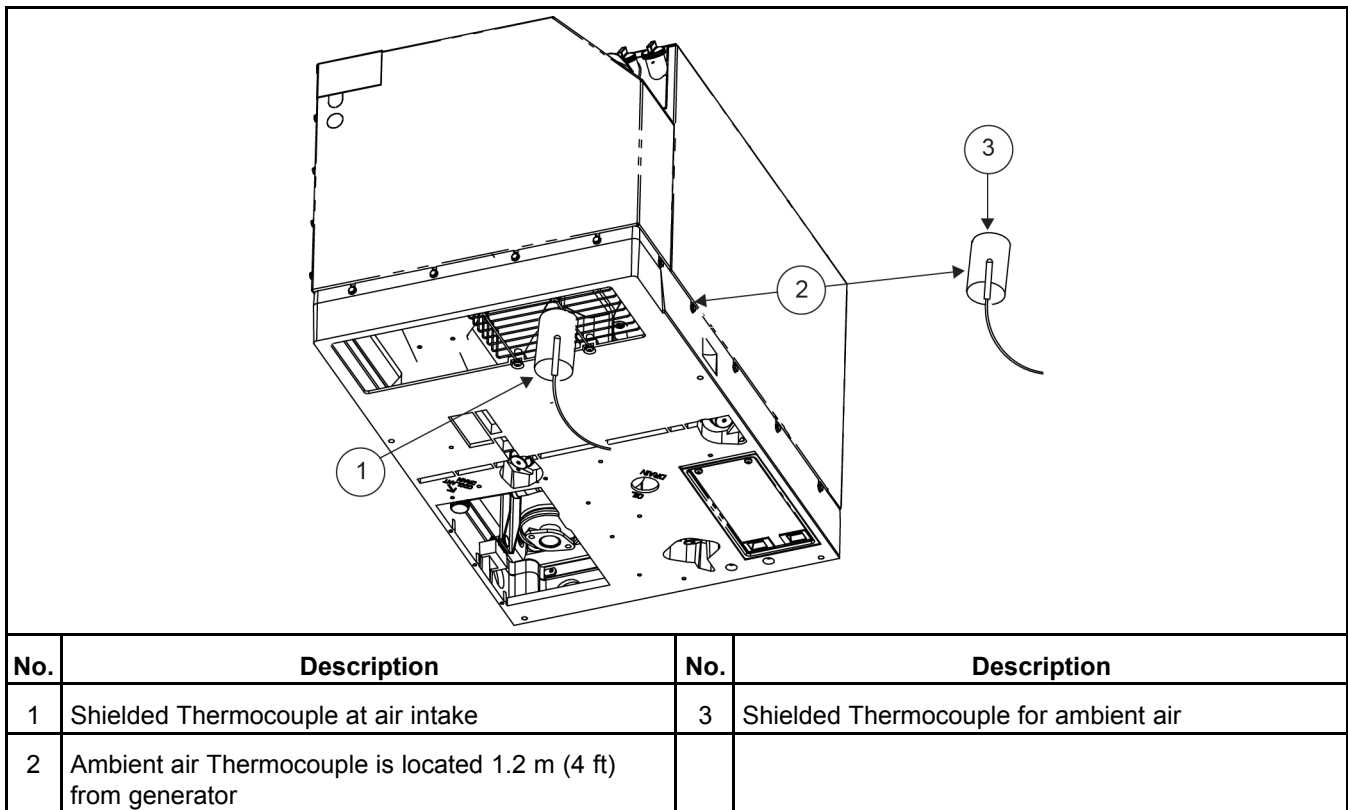

FIGURE 19. THERMOCOUPLE LOCATIONS FOR HOT AIR RECIRCULATION TEST

7.3.2 Test Requirement

The best installations will have the generator set air intake temperature as close to the ambient air temperature as possible. If generator set air intake temperature is high, it may be from air recirculation or other sources of heat (vehicle engine, hot pavement, etc.). Mudflaps, air direction vanes, ducts, brush seals, or other modifications may be required to improve the cooling performance of the installation. Poor air management is the number one cause of warranty and performance issues in generator set installations. As a guide, the air intake temperature at the generator set air inlet should not be higher than the ambient temperature by more than 3–6 °C (5–10 °F).

Appendix A. Wiring Diagrams

Table of Contents

Figure 20. WIRING DIAGRAM 0611-1236	43
Figure 21. FC32 TROUBLESHOOTING WIRING DIAGRAM	44

This page is intentionally blank.

A.0 Wiring Diagrams (0611-1236)

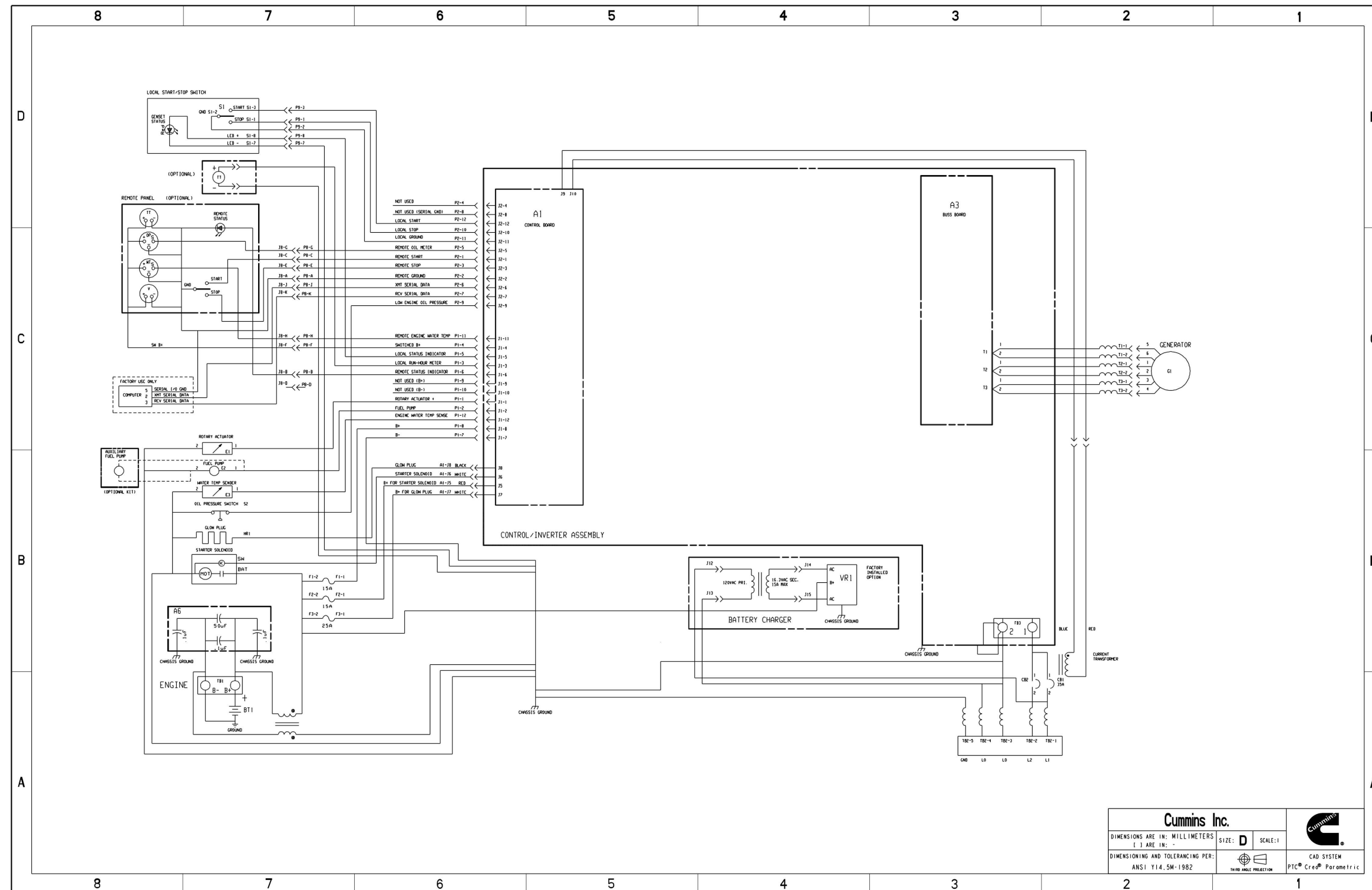

Part Number: **0611-1236** Part Revision: **A**
Part Name: **CONTROL,GENSET**

FIGURE 20. WIRING DIAGRAM 0611-1236

A.1 FC32 TS Wiring Diagram

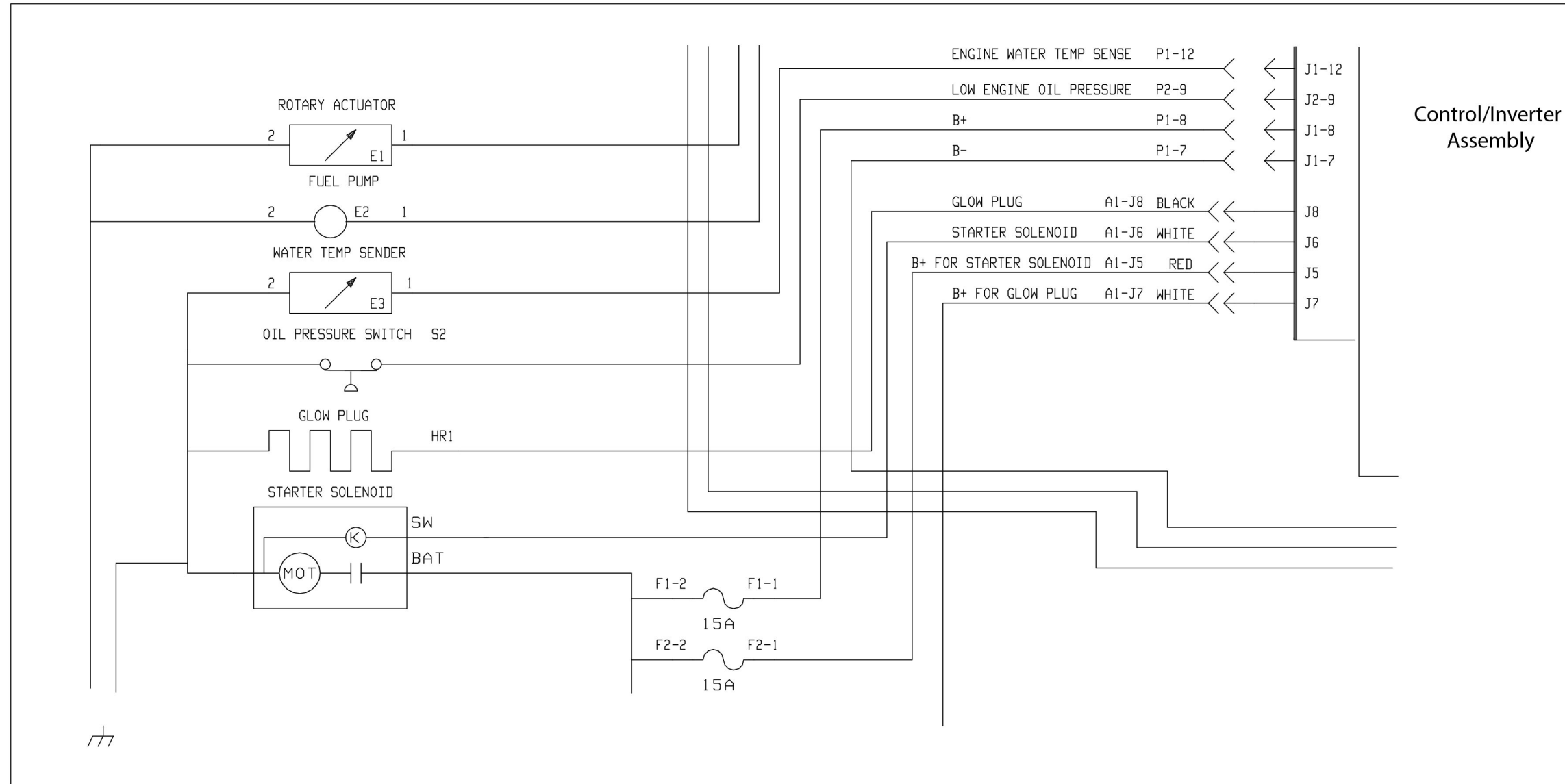

FIGURE 21. FC32 TROUBLESHOOTING WIRING DIAGRAM

Appendix B. Outline Drawings

Table of Contents

Figure 22. Outline Drawing 0500-3159	47
--	----

This page is intentionally blank.

B.0 Outline Drawing (0500-3159)

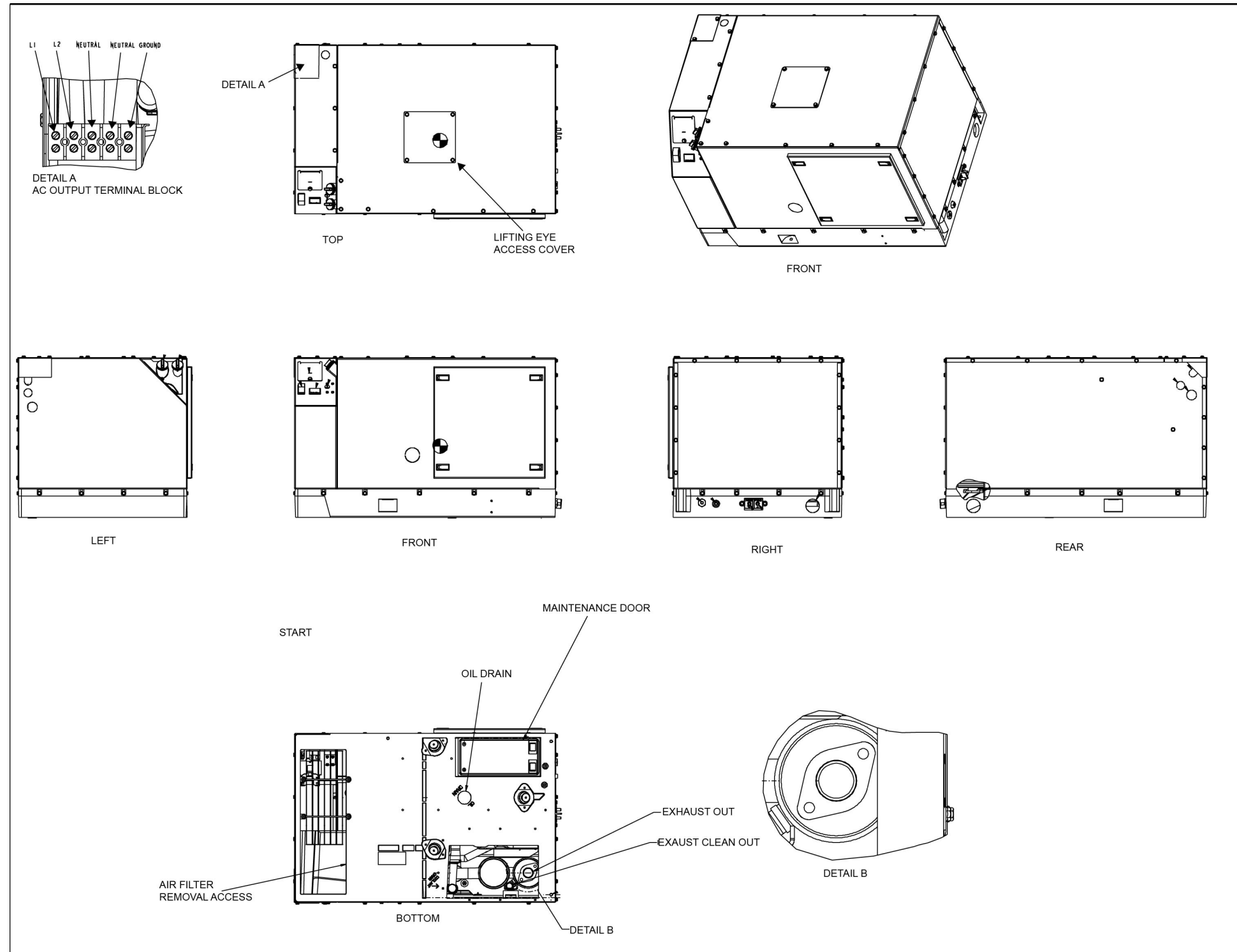

FIGURE 22. OUTLINE DRAWING 0500-3159

This page is intentionally blank.

power.cummins.com

Copyright © 2020 Cummins Inc. All rights reserved.

Cummins, Onan, and the "C" logo are registered trademarks of Cummins Inc. and its subsidiaries.

Other company, product, or service names may be trademarks or service marks of others.

Specifications are subject to change without notice.

