



**Generator Systems**

## **Installation & Start-Up Manual**



**Generator System**



**Thank you** for purchasing this quality-built Briggs & Stratton home generator. We are pleased that you've placed your confidence in the Briggs & Stratton brand. When operated and maintained according to the instructions in the operator's manual, your home generator will provide many years of dependable service.

**This manual contains** safety information to make you aware of the hazards and risks associated with residential generator systems and how to avoid them. This generator system is designed and intended only for use as an optional home standby system that provides an alternate source of electric power and to serve loads such as heating, refrigeration systems, and communication systems that, when stopped during any power outage, could cause discomfort or inconvenience. **Save these original instructions for future reference.**

**This generator system requires professional installation before use.** The installer should follow the instructions completely.

### Where to Find Us

You never have to look far to find support and service for your generator. Consult your Yellow Pages. There are many Briggs & Stratton authorized service dealers worldwide who provide quality service. You can also contact Briggs & Stratton Customer Service by phone at **800-743-4115** between 8:00 AM and 5:00 PM CT., or click on Find a Dealer at BRIGGSandSTRATTON.COM, which provides a list of authorized dealers.

### For Future Reference

Please fill out the information below and keep with your receipt to assist in unit identification for future purchase issues.

**Date of Purchase**             

### Generator

**Model Number**   

**Model Revision**   

**Serial Number**   

### Engine

**Model Number**   

**Serial Number**   

Briggs & Stratton Power Products Group, LLC  
P.O. Box 702  
Milwaukee, WI 53201-0702

Copyright © 2012. All rights reserved. No part of this material may be reproduced or transmitted in any form without the express written permission of Briggs & Stratton Power Products Group, LLC.

# Table of Contents

<b>Important Safety Instructions</b> . . . . .	<b>4</b>
<b>Installation</b> . . . . .	<b>7</b>
Owner Responsibilities . . . . .	7
Installing Dealer/Contractor Responsibilities . . . . .	7
Cold Weather Kit . . . . .	7
Unpacking Precautions . . . . .	8
Delivery Inspection . . . . .	8
Shipment Contents . . . . .	8
Installation Checklist . . . . .	9
Generator Placement . . . . .	11
Placement of Standby Generator to REDUCE THE RISK OF CARBON MONOXIDE POISONING . . . . .	12
Other General Location Guidelines . . . . .	13
Placement of Standby Generator to REDUCE THE RISK OF FIRE . . . . .	14
Electrical and Fuel Inlet Locations . . . . .	16
Lifting the Generator . . . . .	17
Concrete Anchoring of Unit . . . . .	17
Access Ports . . . . .	18
The Gaseous Fuel System . . . . .	20
Fuel Consumption . . . . .	21
Fuel Pressure . . . . .	21
Power Loss . . . . .	21
Fuel Pipe Sizing . . . . .	21
Fuel Conversion . . . . .	22
System Connectors . . . . .	23
Generator AC Connection System . . . . .	24
Grounding the Generator . . . . .	25
Utility Circuit Connection . . . . .	25
Generator Power Connection . . . . .	25
Transfer Switch Communication . . . . .	25
System Control Panel . . . . .	26
Final Installation Considerations . . . . .	31
Initial Start-up (No Load) . . . . .	32
Electronic Governor System . . . . .	33
Installation Inspection . . . . .	34
<b>Operation</b> . . . . .	<b>34</b>
Automatic Operation Sequence . . . . .	34
Setting Exercise Timer . . . . .	34
<b>Schematic / Wiring Diagrams</b> . . . . .	<b>35</b>

# Save These Instructions

## Important Safety Instructions

**SAVE THESE INSTRUCTIONS** - This manual contains important instructions that should be followed during installation and maintenance of the generator and batteries.

### Safety Symbols and Meanings



Explosion



Fire



Electrical Shock



Toxic Fumes



Rotating Parts



Hot Surface



Auto Start



Explosive Pressure



Chemical Burn



Lift Hazard



Read Manual

▲ The safety alert symbol indicates a potential personal injury hazard. A signal word (DANGER, WARNING, or CAUTION) is used with the alert symbol to designate a degree or level of hazard seriousness. A safety symbol may be used to represent the type of hazard. The signal word NOTICE is used to address practices not related to personal injury.

▲ **DANGER** indicates a hazard which, if not avoided, *will* result in death or serious injury.

▲ **WARNING** indicates a hazard which, if not avoided, *could* result in death or serious injury.

▲ **CAUTION** indicates a hazard which, if not avoided, *could* result in minor or moderate injury.

**NOTICE** addresses practices not related to personal injury.

The manufacturer cannot possibly anticipate every possible circumstance that might involve a hazard. The warnings in this manual, and the tags and decals affixed to the unit are, therefore, not all-inclusive. If you use a procedure, work method or operating technique that the manufacturer does not specifically recommend, you must satisfy yourself that it is safe for you and others. You must also make sure that the procedure, work method or operating technique that you choose does not render the generator system unsafe.

▲ **WARNING** Running engine gives off carbon monoxide, an odorless, colorless, poison gas.



Breathing carbon monoxide could result in death, serious injury, headache, fatigue, dizziness, vomiting, confusion, seizures, nausea or fainting.

- Operate this product **ONLY** outdoors in an area that will not accumulate deadly exhaust gas.
- Keep exhaust gas away from any windows, doors, ventilation intakes, soffit vents, crawl spaces, open garage doors or other openings that can allow exhaust gas to enter inside or be drawn into a potentially occupied building or structure.
- Carbon monoxide detector(s) **MUST** be installed and maintained indoors according to the manufacturer's instructions/recommendations. Smoke alarms cannot detect carbon monoxide gas.

▲ **WARNING** The engine exhaust from this product contains chemicals known to the State of California to cause cancer, birth defects, or other reproductive harm.

▲ **WARNING** Certain components in this product and related accessories contain chemicals known to the State of California to cause cancer, birth defects, or other reproductive harm. Wash hands after handling.

▲ **WARNING** Storage batteries give off explosive hydrogen gas during recharging. Slightest spark will ignite hydrogen and cause explosion, resulting in death, serious injury and/or property damage.



Battery electrolyte fluid contains acid and is extremely caustic.

Contact with battery contents could cause severe chemical burns.

A battery presents a risk of electrical shock and high short circuit current.

- DO NOT dispose of battery in a fire. Recycle battery.
- DO NOT allow any open flame, spark, heat, or lit cigarette during and for several minutes after charging a battery.
- DO NOT open or mutilate the battery.
- Wear protective goggles, rubber apron, rubber boots and rubber gloves.
- Remove watches, rings, or other metal objects.
- Use tools having insulated handles.

 **WARNING** Propane and Natural Gas are extremely flammable and explosive, which could cause burns, fire or explosion resulting in death, serious injury and/or property damage.

- Install the fuel supply system according to NFPA 37 and other applicable fuel-gas codes.
- Before placing the generator into service, the fuel system lines must be properly purged and leak tested.
- After the generator is installed, you should inspect the fuel system periodically.
- NO leakage is permitted.
- DO NOT operate engine if smell of fuel is present or other explosive conditions exist.
- DO NOT smoke around the generator. Wipe up any oil spills immediately. Ensure that no combustible materials are left in the generator compartment. Keep the area near the generator clean and free of debris.

 **WARNING** Hazardous Voltage - Contact with power lines could cause electric shock or burns, resulting in death or serious injury.  
Lifting Hazard / Heavy Object - Could result in serious injury.

- If lifting or hoisting equipment is used, DO NOT contact any power lines.
- DO NOT lift or move generator without assistance.
- Use lifting pipes as described in *Lifting the Generator*.
- DO NOT lift unit by roof as damage to generator will occur.

 **WARNING** Generator produces hazardous voltage.

Failure to properly ground generator could result in electrocution.  
Failure to isolate generator from utility power could result in death or serious injury to electric utility workers due to backfeed of electrical energy.

- When using generator for backup power, notify utility company.
- DO NOT touch bare wires or bare receptacles.
- DO NOT use generator with electrical cords which are worn, frayed, bare or otherwise damaged.
- DO NOT handle generator or electrical cords while standing in water, while barefoot, or while hands or feet are wet.
- If you must work around a unit while it is operating, stand on an insulated dry surface to reduce the risk of a shock hazard.
- DO NOT allow unqualified persons or children to operate or service generator.
- In case of an accident caused by electrical shock, immediately shut down the source of electrical power and contact the local authorities. **Avoid direct contact with the victim.**
- Despite the safe design of the generator, operating this equipment imprudently, neglecting its maintenance or being careless could cause possible injury or death.
- Remain alert at all times while working on this equipment. Never work on the equipment when you are physically or mentally fatigued.
- Before performing any maintenance on the generator, disconnect the battery cable indicated by a **NEGATIVE, NEG** or (-) first. When finished, reconnect that cable last.
- After your system is installed, the generator may crank and start without warning any time there is a power failure. To prevent possible injury, always set the generator's system switch to **OFF**, remove the service disconnect from the disconnect box AND remove the 15 Amp fuse BEFORE working on the equipment.

**▲ WARNING** Exhaust heat/gases could ignite combustibles or structures resulting in death, serious injury and/or property damage. Contact with muffler area could cause burns resulting in serious injury.



- DO NOT touch hot parts and AVOID hot exhaust gases.
- Allow equipment to cool before touching.
- Exhaust outlet side of weatherproof enclosure must have at least 5 ft. (1.5 m) minimum clearance from any structure, shrubs, trees or any kind of vegetation.
- Standby generator weatherproof enclosure must be at least 5 ft. (1.5 m) from windows, doors, any wall opening, shrubs or vegetation over 12 inches (30.5 cm) in height.
- Standby generator weatherproof enclosure must have a minimum of 5 ft. (1.5 m) overhead clearance from any structure, overhang or trees.
- DO NOT place weatherproof enclosure under a deck or other type of structure that may confine airflow.
- Use only flexible fuel line provided. Connect provided fuel line to generator, DO NOT use with or substitute any other flexible fuel line.
- Smoke detector(s) MUST be installed and maintained indoors according to the manufacturer's instructions/recommendations. Carbon monoxide alarms cannot detect smoke.
- Keep at least minimum distances shown in *General Location Guidelines* to insure for proper generator cooling and maintenance clearances.
- It is a violation of California Public Resource Code, Section 4442, to use or operate the engine on any forest-covered, brush-covered, or grass-covered land unless the exhaust system is equipped with a spark arrester, as defined in Section 4442, maintained in effective working order. Other states or federal jurisdictions may have similar laws. Contact the original equipment manufacturer, retailer, or dealer to obtain a spark arrester designed for the exhaust system installed on this engine.
- Replacement parts must be the same and installed in the same position as the original parts.

**▲ WARNING** Starter and other rotating parts could entangle hands, hair, clothing, or accessories resulting in serious injury.



- NEVER operate generator without protective housings, covers, or guards in place.
- DO NOT wear loose clothing, jewelry or anything that could be caught in the starter or other rotating parts.
- Tie up long hair and remove jewelry.
- Before servicing, remove 15 Amp fuse from control panel and disconnect **Negative (NEG or -)** battery cable.

**▲ CAUTION** Installing the 15A fuse could cause the engine to start at any time without warning resulting in minor or moderate injury.



- Observe that the 15 Amp fuse has been removed from the control panel for shipping.
- DO NOT install this fuse until all plumbing and wiring has been completed and inspected.

**▲ CAUTION** Excessively high operating speeds could result in minor injury and/or equipment damage, Excessively low speeds impose a heavy load on generator.

- DO NOT tamper with governed speed. Generator supplies correct rated frequency and voltage when running at governed speed.
- DO NOT modify generator in any way.

**NOTICE** Improper treatment of generator could damage it and shorten its life.

- Use generator only for intended uses.
- If you have questions about intended use, contact your authorized dealer.
- Operate generator only on level surfaces.
- Adequate, unobstructed flow of cooling and ventilating air is critical to correct generator operation.
- The access panels/doors must be installed whenever the unit is running.
- DO NOT expose generator to excessive moisture, dust, dirt, or corrosive vapors.
- Remain alert at all times while working on this equipment. Never work on the equipment when you are physically or mentally fatigued.
- DO NOT start engine with air cleaner or air cleaner cover removed.
- DO NOT insert any objects through cooling slots.
- DO NOT use the generator or any of its parts as a step. Stepping on the unit could cause stress and break parts. This may result in dangerous operating conditions from leaking exhaust gases, fuel leakage, oil leakage, etc.
- If connected devices overheat, turn them off and disconnect them from generator.

Shut off generator and contact an authorized dealer if

- electrical output is lost;
- equipment sparks, smokes, or emits flames;
- unit vibrates excessively;
- unit makes unusual noises.

# Installation

## Equipment Description

This product is only for use as an optional generator system which provides an alternate source of electric power and to serve loads such as heating, refrigeration systems, and communication systems that, when stopped during any power outage, could cause discomfort or inconvenience.

**NOTICE** This product does NOT qualify for either an emergency standby or legally required standby system as defined by NFPA 70 (NEC).

- Emergency generator systems are intended to automatically supply illumination, power, or both, to designated areas and equipment in the event of failure of the normal supply. Emergency systems may also provide power for such functions as ventilation where essential to maintain life, where current interruption of the normal supply would produce serious life safety or health hazards.
- Legally Required standby generator systems are intended to automatically supply power to selected loads in the event of failure of the normal source which could create hazards or hamper rescue or fire-fighting operations.

Every effort has been made to ensure that information in this manual is accurate and current. However, we reserve the right to change, alter, or otherwise improve the product and this document at any time without prior notice.

Only current licensed electrical and plumbing professionals should attempt home generator system installations. Installations must strictly comply with all applicable codes, industry standards, laws and regulations.

## Owner Responsibilities

- Read and follow the instructions given in the operator's manual.
- Follow a regular schedule in maintaining, caring for and using your generator, as specified in the operator's manual.
- Carbon monoxide detector(s) MUST be installed and maintained indoors according to the manufacturer's instructions/recommendations. Smoke alarms cannot detect carbon monoxide gas.
- Smoke detector(s) MUST be installed and maintained indoors according to the manufacturer's instructions/recommendations. Carbon monoxide alarms cannot detect smoke.

If you have questions about intended use, ask your installer or dealer or call 800-743-4115 between 8:00 AM and 5:00 PM CT.

## Installing Dealer/Contractor Responsibilities

- Read and observe the safety rules.
- Install only an UL approved transfer switch that is compatible with the generator.
- Read and follow the instructions given in this installation and start-up manual.
- Installation must strictly comply with all applicable codes, industry standards, laws, and regulations.
- Allow sufficient room on all sides of the generator for maintenance and servicing.

## Cold Weather Kit

If operating the generator below 30°F (-1°C), it is HIGHLY RECOMMENDED that a Model 6231 Cold Weather Kit (includes oil warmers and battery warmer) be installed. These items are available at your local servicing dealer.

For cold weather areas (below 0°F (-18°C)) it is also recommended that a BCI, Size 75, wet lead-acid battery be used of 630 CCA minimum.

If you need more information on this matter, please call (800) 743-4115, between 8:00 AM and 5:00 PM CT.

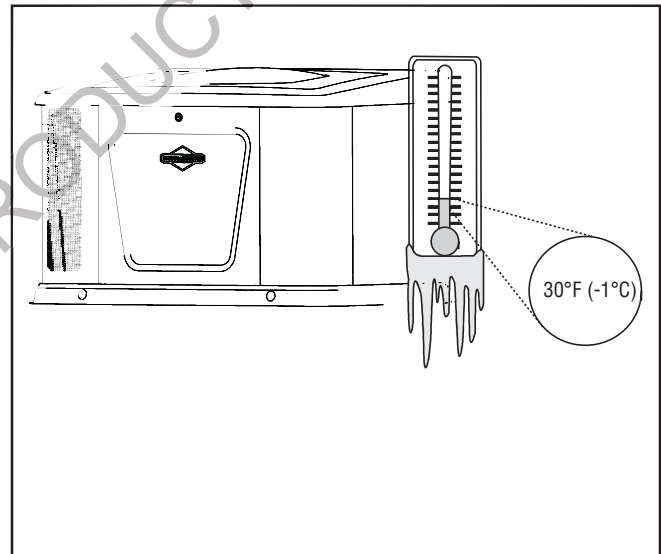

## Unpacking Precautions

The unit is shipped ready for installation. Avoid damage from dropping, bumping, collision, etc. Store and unpack carton with the proper side up, as noted on the shipping carton.

## Delivery Inspection

After removing the carton, carefully inspect the generator for any damage that may have occurred during shipment.

If loss or damage is noted at time of delivery, have the person(s) making delivery note all damage on the freight bill and affix his signature under the consignor's memo of loss or damage. If loss or damage is noted after delivery, separate the damaged materials and contact the carrier for claim procedures. Parts damaged in shipping are not warranted.

## Shipment Contents

### The home generator system is supplied with:

- Oil (5W30 Synthetic)
- Flexible steel fuel line
- Installation and start-up manual
- Operator's manual
- Spare access roof keys
- Spare 15 Amp ATO-type fuse

### Not included:

- Carbon monoxide detector(s)
- Smoke detector(s)
- Starting battery
- Connecting wire and conduit
- Fuel supply valves/plumbing
- Crane, lifting straps, chains or cables
- Two 60" lengths of 3/4" nominal minimum scheduled 40 steel pipe (NOT conduit)
- Torque screwdriver, 5 to 50 inch-pound range
- Voltage/frequency meter

NOT FOR REPRODUCTION



## Installation Checklist

Proper installation of the home generator requires the completion of the following tasks:

### Carbon Monoxide (CO) Detector

- Carbon Monoxide (CO) detector installed and in working order.
- Smoke detector(s) installed and in working order.

### Placement

- Required permits have been obtained.
- Generator placed in an area free from Carbon Monoxide (CO) buildup. **See Placement of Standby Generator to Reduce the Risk of Carbon Monoxide Poisoning.**
- Generator placed in an area compliant to NFPA 37. **See Placement of Standby Generator to Reduce the Risk of Fire.**
- Generator placed in an area free from water damage. **See Other General Location Guidelines.**
- Generator placed in an area free from utility and other home systems. **See Other General Location Guidelines.**
- Generator placed in a debris free zone. **See Other General Location Guidelines.**
- Generator placed on flat ground with provisions for water drainage. **See Other General Location Guidelines.**

### Fuel

- Generator is connected to fuel source with flexible fuel line, has no fuel leaks and conforms to local codes. **See The Gaseous Fuel System.**
- Proper fuel pressure has been measured with all gas appliances operating. **See The Gaseous Fuel System.**
- Fuel system has been configured for the proper fuel supply: Natural gas (NG) or liquefied petroleum (LP). **See Fuel Conversion.**
- Fuel type: (circle one) NG LP
- Fuel pipe size used: (circle one) 3/4" 1" 1-1/4" 1-1/2"  
See NFPA 54, Chapter 6.
- Fuel pressure at fuel inlet port with generator on and at full load and all gas appliances turned on and operating \_\_\_\_\_.

### Electrical

- Generator neutral is connected to Automatic Transfer Switch. **See Generator AC Connection System.**
- Generator is grounded. **See Grounding the Generator and NFPA 70, NEC, Article 250.35B.**
- Generator is connected to the transfer switch with the specified wiring. **See Utility Circuit Connection and Transfer Switch Communication.**
- Generator is connected to the transfer switch with the specified wiring. #18AWG twisted pair wiring from the generator control panel to the transfer switch is installed in a separate conduit from high voltage wires unless the insulation rating on all wiring is rated for 600V. **See Transfer Switch Communication.**
- Dipswitches in most transfer switches must be set to correspond to the wattage of the generator. **See Transfer Switch Operator/Installation Manual.**

### Operation

- Cold weather kit is installed in temperatures below 30°F (4°C). **See Cold Weather Kit.**
- Correct battery type is installed and fully charged. **See Final Installation Considerations.**
- Generator engine oil level is at full mark. **See Final Installation Considerations.**
- Circuit breaker is in the ON position.
- Utility was shut off to test the operation of generator and transfer switch. Note any fault codes and make corrections as required.
- AC Voltage Output \_\_\_\_\_.
- Frequency Output \_\_\_\_\_.

### Owner Information

Name: \_\_\_\_\_

Address: \_\_\_\_\_

Phone/e-mail: \_\_\_\_\_

### Unit Information

Generator Model: \_\_\_\_\_

Generator Serial Number: \_\_\_\_\_

### Installing Contractor Information

Name: \_\_\_\_\_

Address: \_\_\_\_\_

Phone/FAX: \_\_\_\_\_

Electrician: \_\_\_\_\_

Signature: \_\_\_\_\_

Plumber: \_\_\_\_\_

Signature: \_\_\_\_\_

### Inspector Information

Name: \_\_\_\_\_

Address: \_\_\_\_\_

Title: \_\_\_\_\_

Inspection Date: \_\_\_\_\_

**This generator has been installed per the manufacturer's instructions:**

Installing Contractor Signature: \_\_\_\_\_

Date: \_\_\_\_\_

Intentionally Left Blank

NOT  
FOR REPRODUCTION

## Generator Placement

Before installing generator, consult with home owner and convey the following requirements, which must be satisfied before the installation is complete.

There are two equally important safety concerns in regards to carbon monoxide poisoning and fire. There are also several general location guidelines that must be met before the installation is considered complete.

**▲ WARNING** Running engine gives off carbon monoxide, an odorless, colorless, poison gas.



Breathing carbon monoxide could result in death serious injury, headache, fatigue, dizziness, vomiting, confusion, seizures, nausea or fainting.

- Operate this product **ONLY** outdoors in an area that will not accumulate deadly exhaust gas.
- Keep exhaust gas away from any windows, doors, ventilation intakes, soffit vents, crawl spaces, open garage doors or other openings that can allow exhaust gas to enter inside or be drawn into a potentially occupied building or structure.
- Carbon monoxide detector(s) **MUST** be installed and maintained indoors according to the manufacturer's instructions/recommendations. Smoke alarms cannot detect carbon monoxide gas.

## Exhaust Side of the Generator

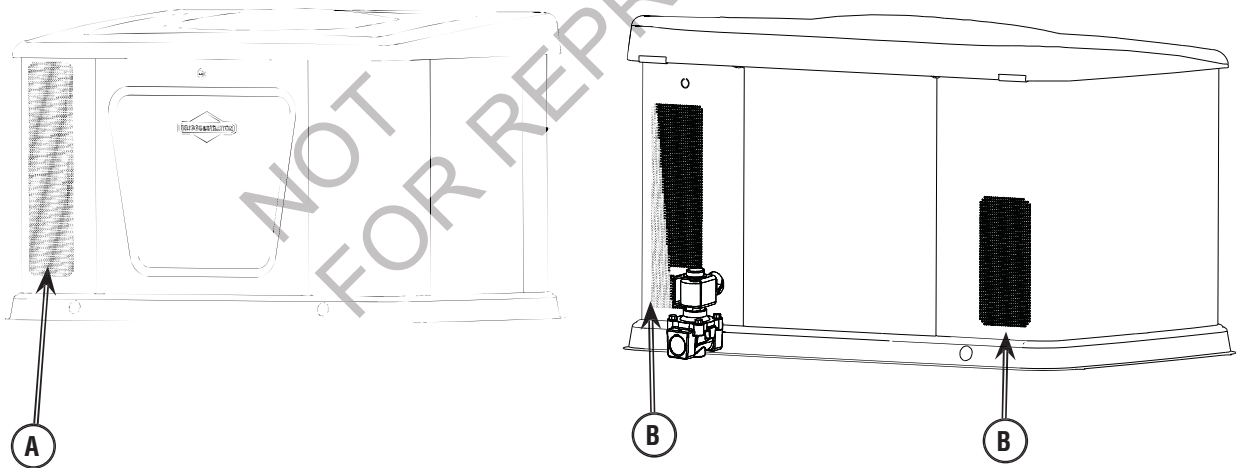

**A** - Exhaust outlet side of weatherproof enclosure

**B** - Air inlet side of weatherproof enclosure

## Placement of Standby Generator to REDUCE THE RISK OF CARBON MONOXIDE POISONING

The arrows in the figure below point to **POTENTIAL** points of entry for Carbon Monoxide Gas.

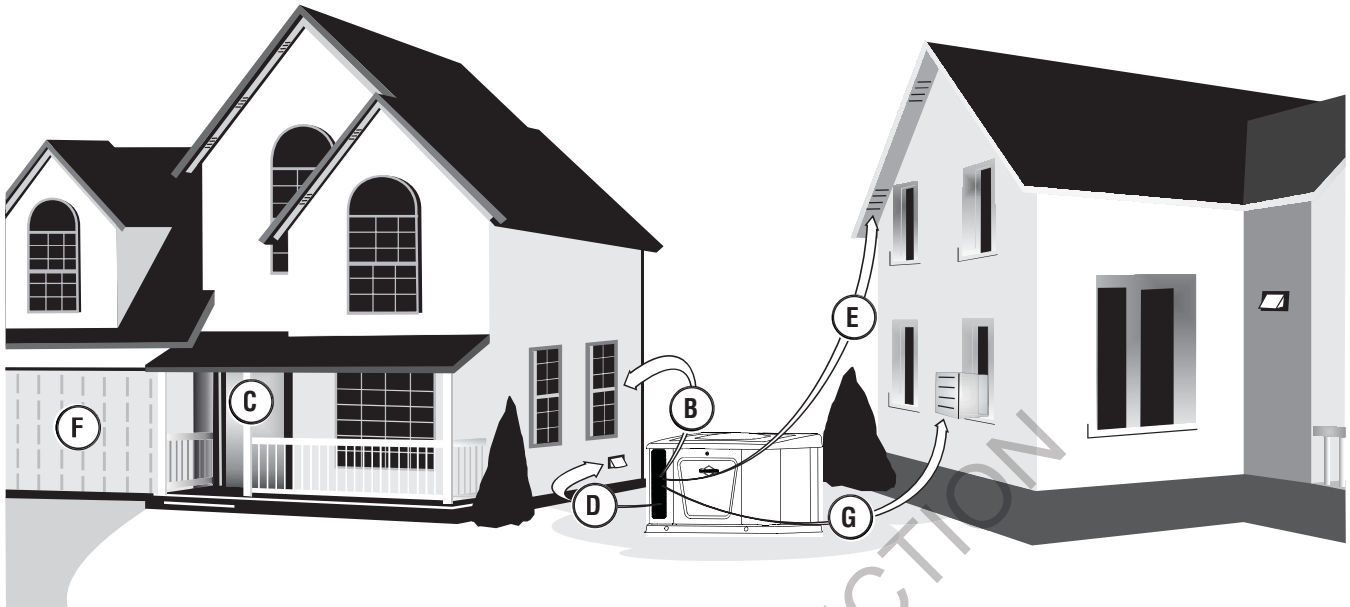

All fossil fuel burning equipment, such as standby generators, contains carbon monoxide (CO) gas in the engine exhaust. CO gas is odorless, colorless and tasteless and is unlikely to be noticed until a person is overcome. CO gas can kill you so it is required that the following is included as part of the installation:

- Install generator outdoors in an area that will not accumulate deadly exhaust gas.
- DO NOT install generator where exhaust gas could accumulate and enter inside or be drawn into a potentially occupied building or structure.
- By law it is required in many states to have a Carbon Monoxide (CO) detector in operating condition in your home. Carbon monoxide detector(s) (A) MUST be installed and maintained indoors according to the manufacturer's instructions / recommendations. A CO monitor is an electric device that detects hazardous levels of CO. When there is a buildup of CO, the monitor will alert the occupants by flashing visual indicator light and alarm. Smoke alarms cannot detect CO gas.
- Your neighbor(s) home may be exposed to the engine exhaust from your standby generator and must be considered when installing your standby generator.

- Ensure exhaust gas is kept away from:

**B** - windows

**C** - doors

**D** - ventilation intakes

**E** - soffit vents

**F** - garage doors

**G** - crawl spaces or other openings that can allow exhaust gas to enter inside or be drawn into a potentially occupied building or structure.

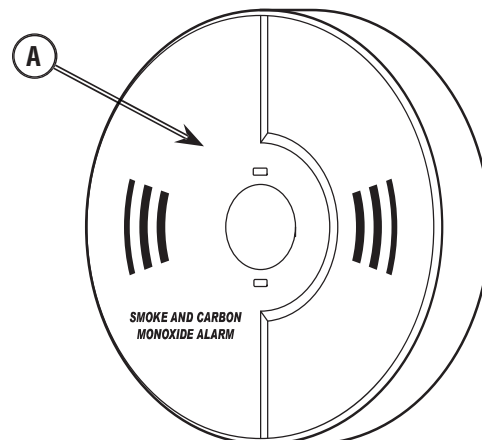

- Direct the standby generator exhaust away from or parallel to the building or structure. DO NOT direct the generator exhaust towards a potentially occupied building, structure, windows, doors, ventilation intakes, soffit vents, crawl spaces, open garage doors or other openings where exhaust gas could accumulate and enter inside or be drawn into potentially occupied building or structure.
- DO NOT place standby generator in any area where leaves or debris normally accumulates. Position standby generator in an area where winds will carry the exhaust gas away from any potentially occupied building or structure.

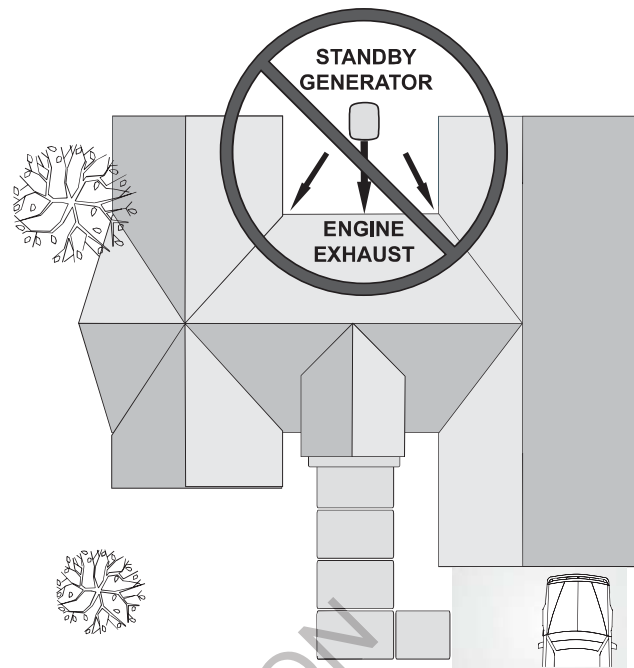

### Other General Location Guidelines

- Place the standby generator in a prepared location that is flat and has provisions for water drainage.
- Install the standby generator in a location where sump pump discharge, rain gutter downspouts, roof run-off, landscape irrigation, or water sprinklers will not flood the unit or spray the enclosure and enter any air inlet or outlet openings.
- Install the standby generator where it will not affect or obstruct services including covered, concealed and underground, such as telephone, electric, fuel (natural gas/ LPG vapor), irrigation, air conditioning, cable, septic, sewer, well and so forth.
- Install the standby generator where leaves, grass, snow, etc. will not obstruct air inlet and outlet openings. If prevailing winds will cause blowing or drifting, you may need to construct a windbreak to protect the unit.

NOT FOR REPRODUCTION

## Placement of Standby Generator to REDUCE THE RISK OF FIRE

### Requirements:

NFPA 37 2010, section 4. 1. 4, Engines Located Outdoors. Engines, and their weatherproof housings if provided, that are installed outdoors shall be located at least 1.5m (5 ft) from openings in walls and at least 1.5 m (5 ft) from structures having combustible walls. A minimum separation shall not be required where either of the following conditions exist:

1. The adjacent wall of the structure has a fire resistance rating of at least 1 hour.
2. The weatherproof enclosure is constructed of noncombustible materials and it has been demonstrated that a fire within the enclosure will not ignite combustible materials outside the enclosure. \*

### Annex A Explanatory Material

A.4.1.4 (2) Means of demonstrating compliance are by means of full-scale fire tests or by calculation procedures, such as those given in NFPA 555, Guide on Methods for Evaluating Potential for Room Flashover.

To comply with condition 2 above the weatherproof enclosure has been constructed completely of non-combustible materials and full-scale fire tests have been conducted to demonstrate that a fire within the enclosure will not ignite combustible materials outside the enclosure.

Examples of standby generator locations to reduce the risk of fire:

### Vertical Clearances

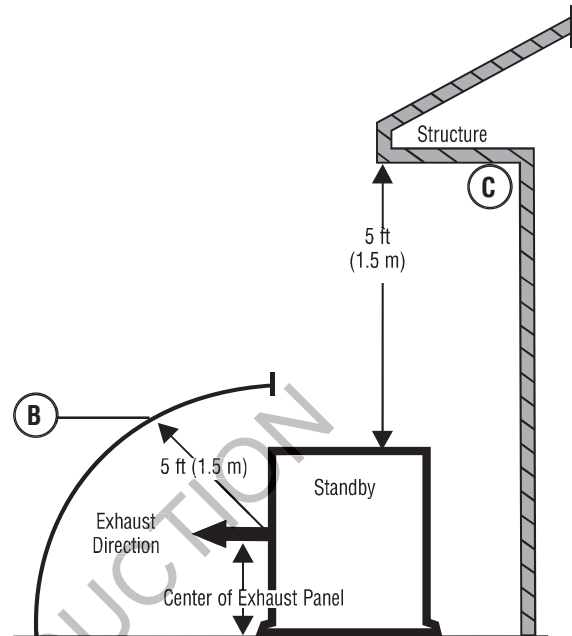

### Legend for Generator Locations to reduce the risk of fire.

- A** Standby weatherproof enclosure must be at least 5 ft (1.5 m) from windows, doors, any wall opening, shrubs or vegetation over 12 inches (30.5 cm) in height.
- B** Exhaust outlet side of weatherproof enclosure must have at least 5 ft (1.5 m) minimum clearance from any structure, shrubs, trees or any kind of vegetation.
- C** Standby weatherproof enclosure must have a minimum of 5 feet (1.5 m) overhead clearance from any structure, overhang or trees.

**NOTICE** DO NOT place weatherproof enclosure under a deck or other type of covered structure that may confine airflow.

**⚠ WARNING** Exhaust heat/gases could ignite combustibles or structures resulting in death, serious injury and/or property damage.

- Exhaust outlet side of weatherproof enclosure must have at least 5 ft. (1.5 m) minimum clearance from any structure, shrubs, trees or any kind of vegetation.
- Standby generator weatherproof enclosure must be at least 5 ft. (1.5 m) from windows, doors, any wall opening, shrubs or vegetation over 12 inches (30.5 cm) in height.
- Standby generator weatherproof enclosure must have a minimum of 5 ft. (1.5 m) overhead clearance from any structure, overhang or trees.
- DO NOT place weatherproof enclosure under a deck or other type of structure that may confine airflow.
- Use only flexible fuel line provided. Connect provided fuel line to generator, DO NOT use with or substitute any other flexible fuel line.
- Smoke detector(s) MUST be installed and maintained indoors according to the manufacturer's instructions/recommendations. Carbon monoxide alarms cannot detect smoke.
- DO NOT place weatherproof enclosure in manner other than shown in illustrations.

## Generator Installations

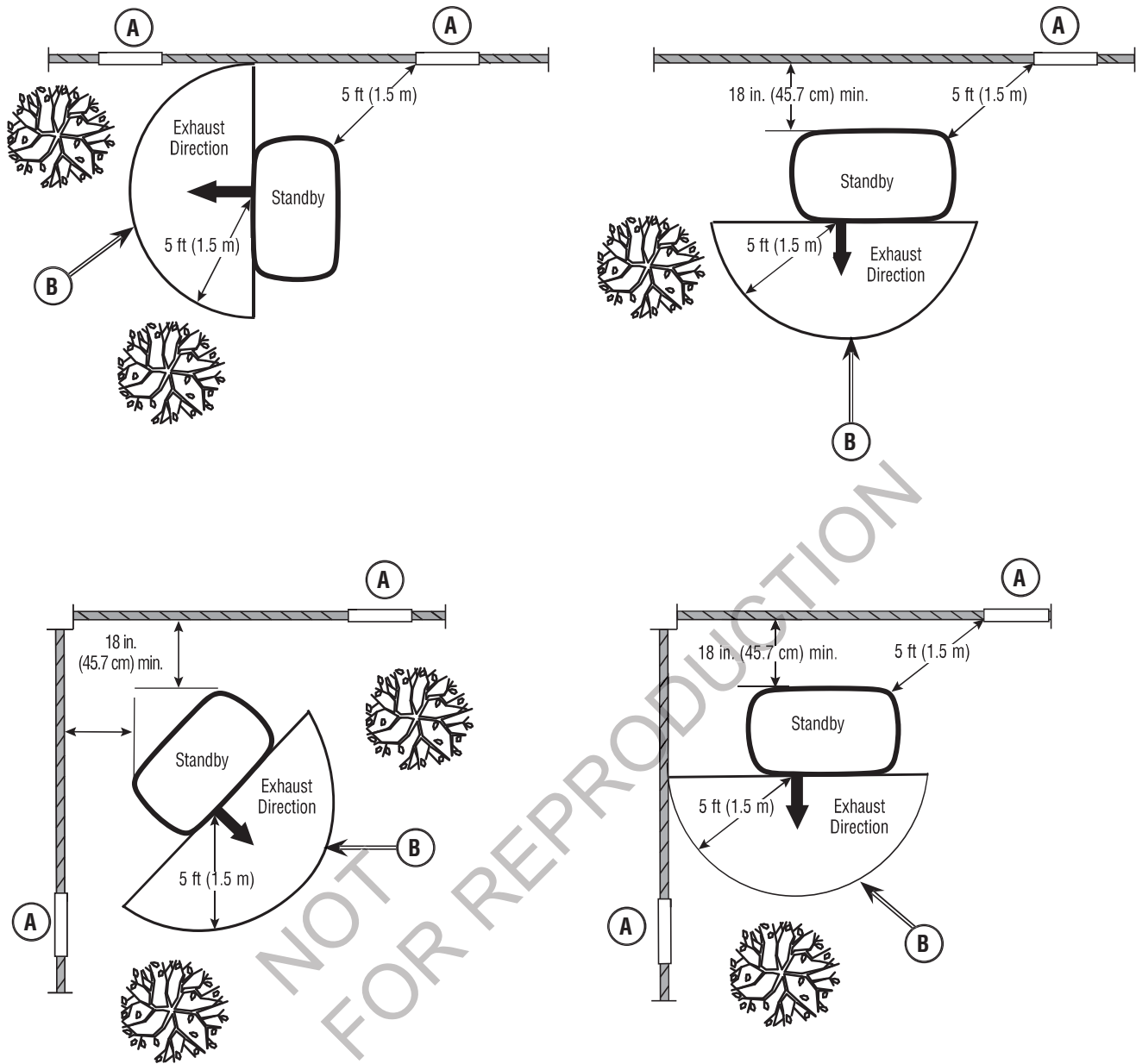

### Legend for Generator Locations to reduce the risk of fire.

- A** Standby weatherproof enclosure must be at least 5 ft (1.5 m) from windows, doors, any wall opening, shrubs or vegetation over 12 inches (30.5 cm) in height.
- B** Exhaust outlet side of weatherproof enclosure must have at least 5 ft (1.5 m) minimum clearance from any structure, shrubs, trees or any kind of vegetation.
- C** Standby weatherproof enclosure must have a minimum of 5 feet (1.5 m) overhead clearance from any structure, overhang or trees.

**NOTICE** DO NOT place weatherproof enclosure under a deck or other type of covered structure that may confine airflow.

## Electrical and Fuel Inlet Locations

The 3/4 inch N.P.T. fuel inlet connector (A) and electrical inlet location (B) is shown below.

A 1/2 inch knock-out is provided for the electrical inlet. This inlet may be enlarged or supplemented to accommodate a maximum conduit size of 1 1/2 inches. Ensure that the installed conduit(s) enter the unit in the zone shown in the drawing such that they properly enter the electrical box and do not interfere with the fully opened roof.

The home generator is supplied with a base that, unless mandated by local code, does not require a concrete slab.

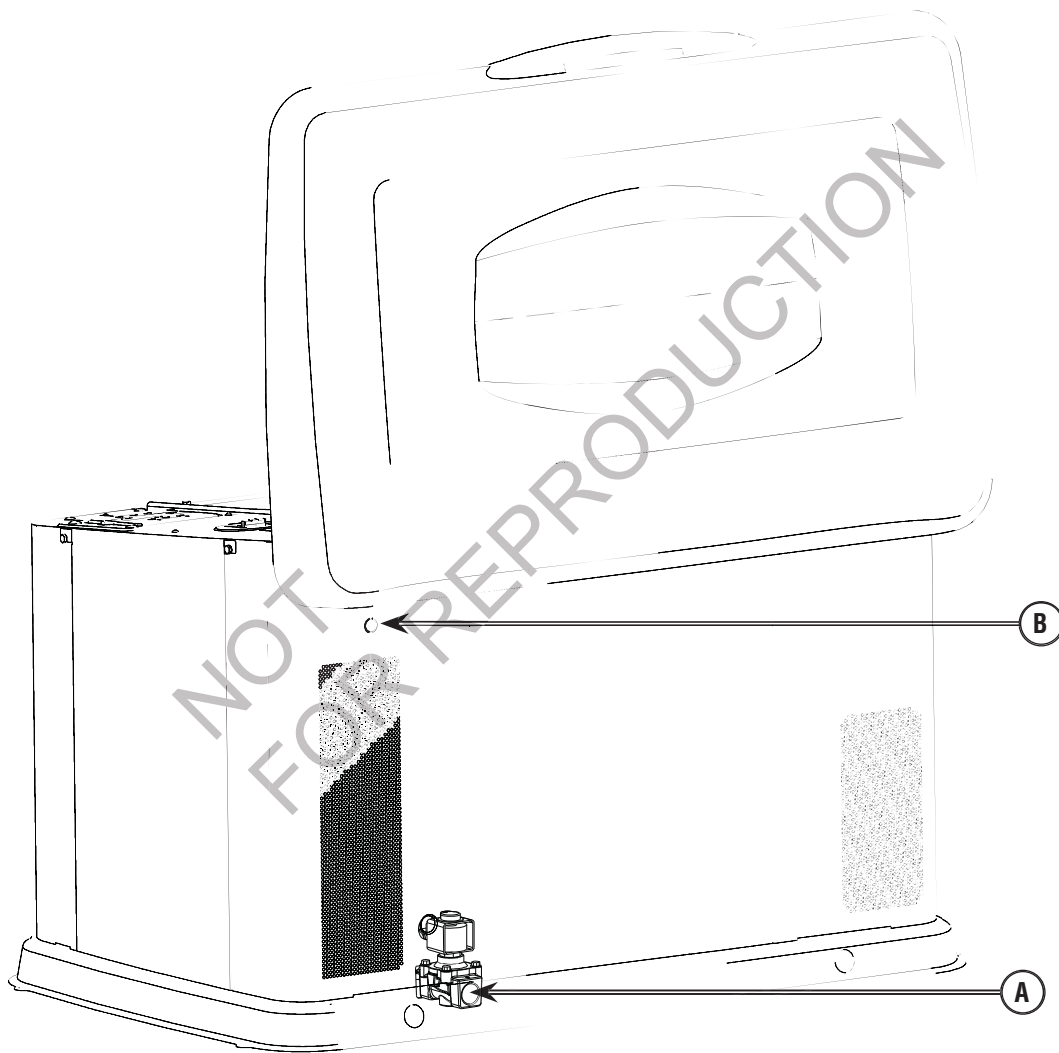



## Lifting the Generator

**⚠ WARNING** Hazardous Voltage - Contact with power lines could cause electric shock or burns, resulting in death or serious injury.  
Lifting Hazard / Heavy Object - Could result in serious injury.

- If lifting or hoisting equipment is used, DO NOT contact any power lines.
- DO NOT lift or move generator without assistance.
- Use lifting pipes as described in *Lifting the Generator*.
- DO NOT lift unit by roof as damage to generator will occur.

The generator weighs more than 500 pounds (227 kg). Proper tools, equipment and qualified personnel should be used in all phases of handling and moving the generator.

Two 60" lengths of 3/4" nominal minimum scheduled 40 steel pipe (A), supplied by the installer, are required to lift the generator manually. Insert pipes through the lifting holes (B) located near the unit's base.

You may also lift the unit using a "hook and hoist" method attached to the lifting pipes, provided that you use a spreader bar to ensure that the chains or cables DO NOT touch the generator's roof.

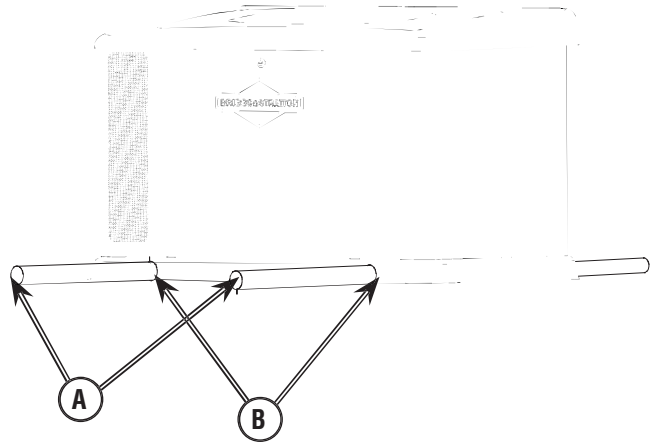

## Concrete Anchoring of Unit

In areas determined to be hurricane prone, it is recommended to anchor the standby generator to concrete. The concrete anchors must be rated to hold 800 lbs ( kg). There are four (C) 7/16 inch hole locations around the base of generator in which to anchor the unit.

**NOTICE** Unless mandated by local or state code, a concrete slab is not required.

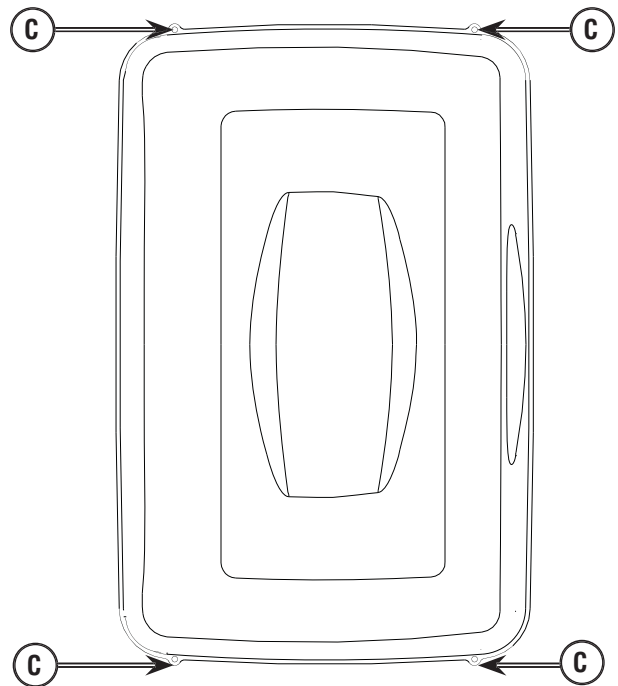

## Access Ports

The generator is equipped with an enclosure that has several access panels, as shown.

The access panels and the components located behind them are listed below:

- A** -Roof (Control Panel, air filter, oil dipstick, and circuit breaker)
- B** -Front Access Panel (oil drain and oil filter)
- C** -Battery Panel (battery and generator data label)
- D** -Rear Access Panel (fuel regulator, fuel selector, and engine starter)
- E** -Control Panel Cover (field wiring and control wires)

Each generator is shipped with a set of identical keys. These keys fit in the lock on the front removable panel. The roof must be unlocked in order for it to open.

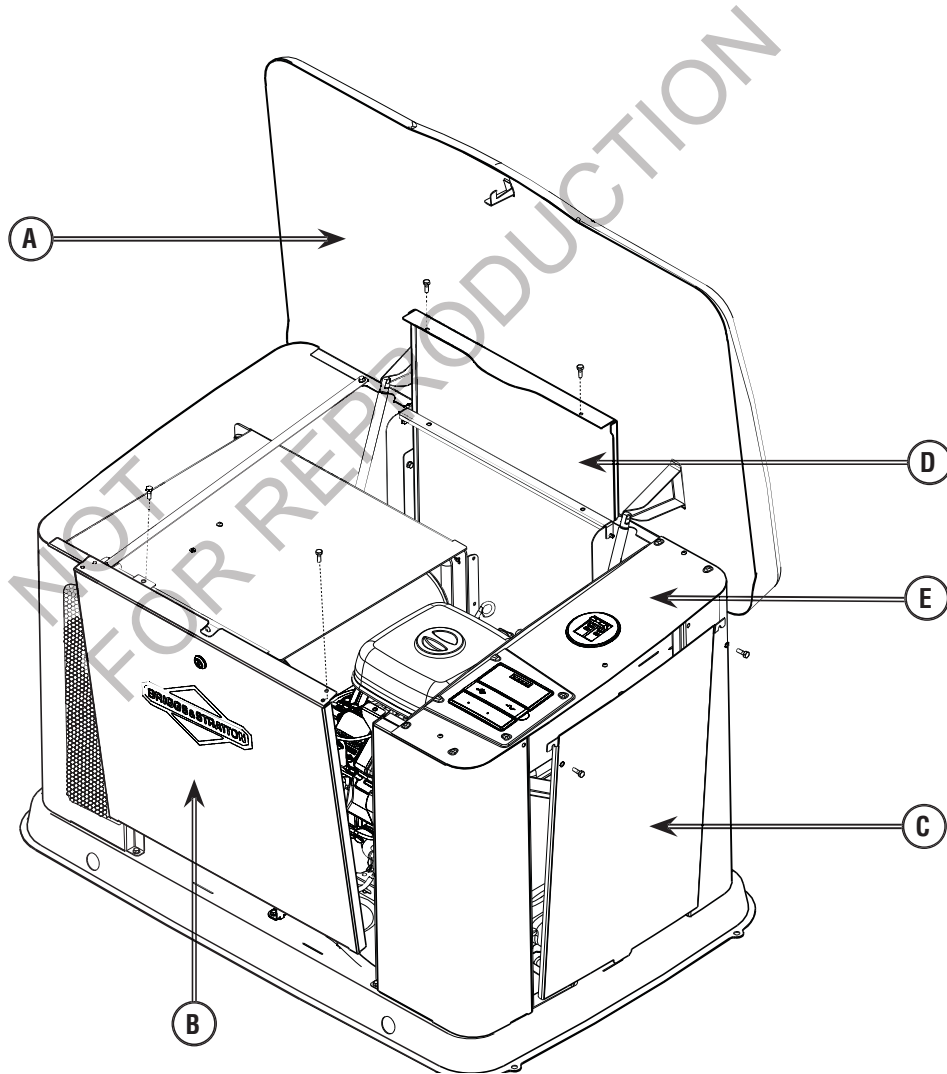

**To open roof:**

1. Insert key into lock (A) of front panel. Gently push down on roof above the lock to aid in turning the key. Turn key one quarter turn clockwise.
2. Lift roof to the open position.

**To remove front panel:**

1. Remove the two bolts (B) that secure the panel to the unit.

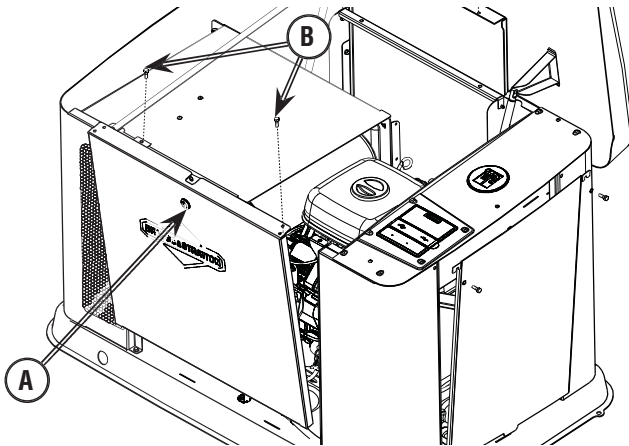

2. Lift panel to remove from unit.

**To secure front panel:**

1. Place panel in unit.
2. Secure the panel with two bolts.

**To remove rear panel:**

1. Ensure the roof is in the open position.
2. Remove the two bolts (C) that secure the panel to the unit.

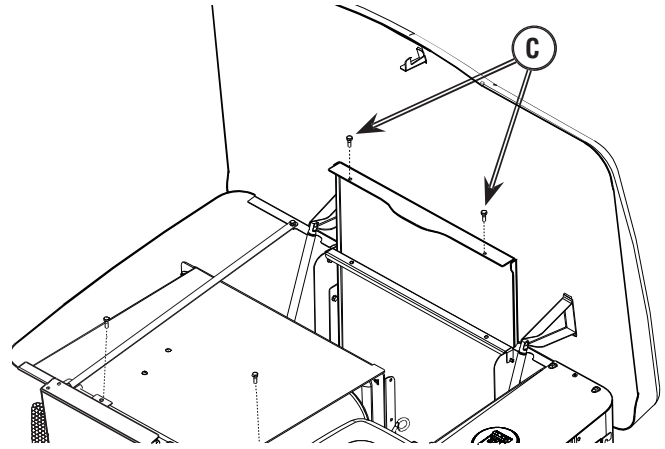

3. Lift panel to remove from unit.

**To secure rear panel:**

1. Slide panel into place on unit.
2. Secure the panel with two bolts.

**To remove battery panel:**

1. Ensure the roof is in the open position.
2. Remove the two bolts (D) that secure the panel to the unit.

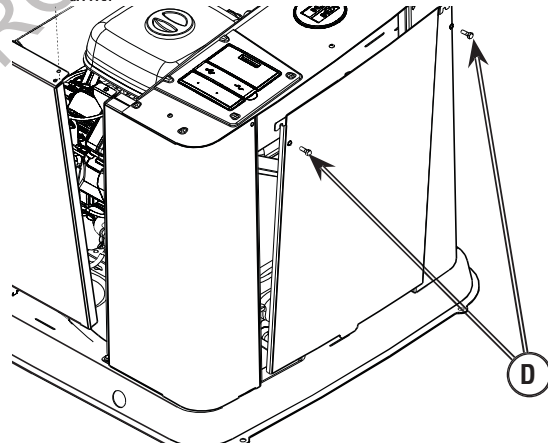

3. Lift up on panel and remove.

**To secure battery panel:**

1. Place panel in unit.
2. Secure the panel with two bolts.

NOT FOR REPRODUCTION

## The Gaseous Fuel System

The information below is provided to assist gaseous fuel system technicians in planning installations. In no way should this information be interpreted to override applicable fuel gas codes. Consult with your local fuel supplier or Fire Marshall if questions or problems arise.

**▲ WARNING** Propane and Natural Gas are extremely flammable and explosive, which could cause burns, fire or explosion resulting in death, serious injury and/or property damage.

- LP gas is heavier than air and will settle in low areas.
- Natural gas is lighter than air and will collect in high areas.
- The slightest spark could ignite these fuels and cause an explosion.
- DO NOT light a cigarette or smoke.

**TO THE INSTALLER: Consult with the generator owner(s) and convey any technical considerations that might affect their installation plans before applying these general guidelines.**

The following general rules apply to gaseous fuel system piping:

**▲ WARNING** Propane and Natural Gas are extremely flammable and explosive, which could cause burns, fire or explosion resulting in death, serious injury and/or property damage.

- Before placing the generator into service, the fuel system lines must be properly purged and leak tested.
- No leakage is permitted.

**NOTICE** The supplied flexible steel fuel line is not to be installed underground or in contact with the ground.

- The entire flexible steel fuel line must be visible for periodic inspection and must not be concealed within nor contact nor run through any wall, floor, or partition.
- The piping should be of a material that conforms to federal and local codes, rigidly mounted and protected against vibration.
- Piping should be protected from physical damage where it passes through flower beds, shrub beds, and other cultivated areas where damage could occur.

**NOTICE** The illustration is representative of a typical installation. Your installation may differ.

- Install the flexible steel fuel line (B) (supplied) between the generator fuel inlet port (A) and rigid piping to prevent thermal expansion, contraction, or any standby movement from causing excessive stress on the piping material.

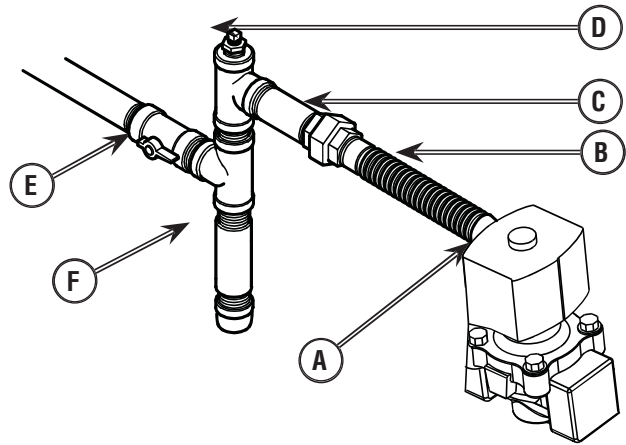

- A union (C) or flanged connection shall be provided downstream to permit removal of standby.
- A manometer port should be provided (D). A digital manometer, P/N 19495, is available at your Briggs & Stratton service center. When the initial test runs are completed, the manometer is removed and the port is plugged. The manometer port permits temporary installation of a manometer to ensure that the engine receives the correct fuel pressure to operate efficiently throughout its operating range.
- Where the formation of hydrates or ice is known to occur, piping should be protected against freezing. The termination of hard piping should include a sediment trap (F) where condensate is not likely to freeze.
- A minimum of one accessible, approved manual shutoff valve (E) shall be installed in the fuel supply line within 6 ft. (180 cm) of the home generator.
- A manual fuel shut-off valve should be installed in the interior of the building.
- Where local conditions include earthquake, tornado, unstable ground, or flood hazards, special consideration shall be given to increase strength and flexibility of piping supports and connections. • Piping must be of the correct size to maintain the required supply pressures and volume flow under varying generator load conditions with all gas appliances connected to the fuel system turned on and operating.
- Use a pipe sealant or joint compound approved for use with NG/LPG on all threaded fittings to reduce the possibility of leakage.
- Installed piping must be properly purged and leak tested, in accordance with applicable codes and standards.

## Fuel Consumption

Estimated fuel supply requirements at half and full load for natural gas and LP vapor fuels are shown below.

### LP Vapor (Propane)

		20kW	16kW	15kW
Full Load	Cu Ft/Hr	135	113	109
	Gal/Hr (liquid)	3.75	3.14	3.03
	BTU/Hr	337500	282500	272500
3/4 Load	Cu Ft/Hr	109	96	90
	Gal/Hr (liquid)	3.03	2.67	2.5
	BTU/Hr	272500	240000	225000
1/2 Load	Cu Ft/Hr	83	71	68
	Gal/Hr (liquid)	2.31	1.97	1.89
	BTU/Hr	207500	177500	170000
1/4 Load	Cu Ft/Hr	56	53	51
	Gal/Hr (liquid)	1.56	1.47	1.42
	BTU/Hr	140000	132500	127500
Exercise	Cu Ft/Hr	40	40	40
	Gal/Hr (liquid)	1.11	1.11	1.11
	BTU/Hr	100000	100000	100000

### Natural Gas

		20 kW (18 kW)	16 kW (14.4 kW)	15kW (13.5 kW)
Full Load	Cu Ft/ Hr	260	244	240
	BTU / Hr	260000	244000	240000
3/4 Load	Cu Ft/ Hr	240	212	210
	BTU / Hr	240000	212000	210000
1/2 Load	Cu Ft/ Hr	187	163	156
	BTU / Hr	187000	163000	156000
1/4 Load	Cu Ft/ Hr	135	125	119
	BTU / Hr	135000	125000	119000
Exercise	Cu Ft/ Hr	99	99	99
	BTU / Hr	99000	99000	99000

Recommended Energy Content of Fuel	LP Vapor	Natural Gas
Heating Value:		
BTU per gallon (gross**)	91,547	
Cubic feet (gas)	2,500	1,000

### Fuel Pressure

Both LP vapor and natural gas fuel supply pressure at the generator's fuel inlet port should be between the following levels at full load with all gas appliances turned on and operating.

- NG is 5-7" W.C.
- LP is 11-14" W.C.

Ensure that all gas line shutoff valves are OPEN and that adequate fuel pressure is available whenever automatic operation is desired.

### Power Loss

Air density is less at high altitudes, resulting in less available engine power. Specifically, engine power will decrease 3.5% for each 1,000 feet (300 meters) above sea level and 1% for each 10° F (5.6°C) above 77°F (25°C). Make sure you and your installer consider these factors when determining total generator load.

### Fuel Pipe Sizing

There are numerous on-line or otherwise-published references for fuel pip sizing. For example, NFPA 54-Natural Fuel Gas Code, 2006 (Item #: 320-6031-06) is a common resource.

The installer should consider the specific gravity of gas and compensate for a nominal amount of restriction from bends, fittings, etc. If an unusual number of fittings, bends, or other restrictions are used, refer to federal and local codes for guidance.

## Fuel Conversion

The engine of your generator system is factory calibrated to run on natural gas (NG) or on liquefied petroleum (LP) vapor. To convert to either fuel, follow these steps:

**NOTICE** Units are set to NG at the factory.

1. Insert key into lock of front panel. Gently push down on roof above the lock to aid in turning the key. Turn key one quarter turn clockwise.
2. Lift roof to the open position.
3. Press the control board **OFF** button.
4. Remove 15 Amp fuse from control panel.
5. Remove the rear panel.
6. Locate the fuel selector switch (**A**), located on top of the fuel regulator (**B**). Using a 5 mm Allen wrench, turn the selector switch to either LP or NG.
7. Install tamper proof plug supplied with unit. Plug fits over fuel selector switch with convex side facing out. Secure plug with drop of cyanoacrylate (super) glue.
8. Reinstall the rear panel.
9. Reinstall 15 Amp fuse in control panel.
10. Press the control board **AUTO** button.

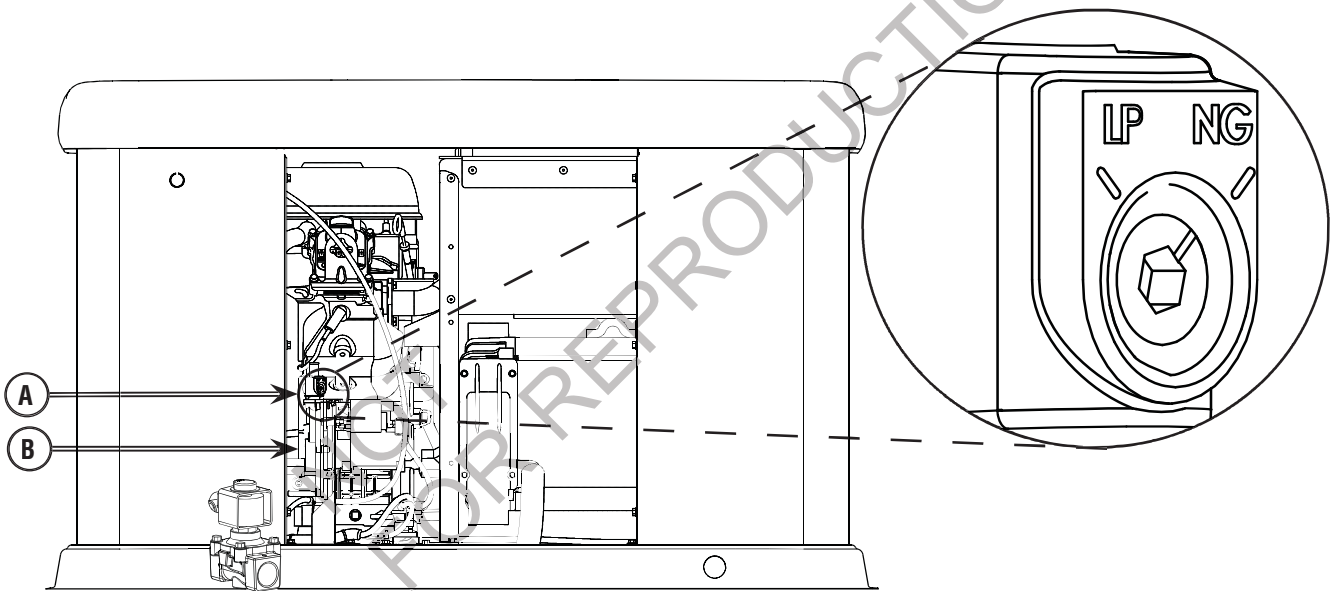

## System Connectors

Low Voltage connections to signal fault contacts, transfer switch communication and auxiliary 12VDC power are made via a field connection terminal block in control board area. **Compare this illustration with your generator to familiarize yourself with the location of these connections.**

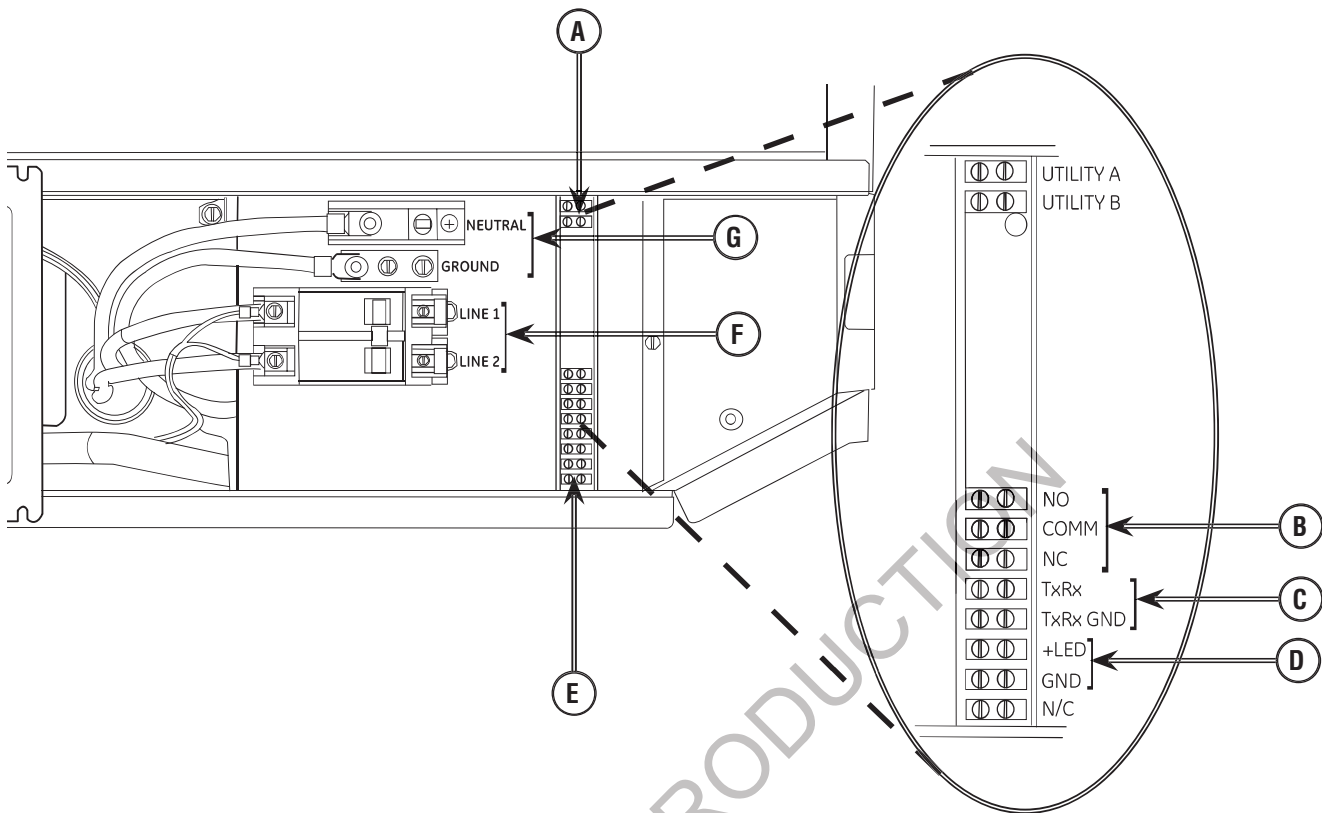

**A - Two Pin Terminal Block** — Used to connect utility 240 VAC from fuse block in ATS to the control board. Connect only one wire per terminal.

**B - Fault Contacts** — Use NO, COM and NC to hook up a siren, light, etc. to alert you in case of a fault. Contacts reverse state (NO goes to NC and vice versa) upon a fault condition.

**C - Transfer Switch Communication (TxRx and TxRx GND)** — Connect to transfer switch control board for communication interface using 18AWG twisted pair wire.

**D - +LED and GND Connection** — Not required for optional wireless monitor. Available for optional hardwired remote system status panel accessory, #6154.

**E - Eight Pin Terminal Block** — Used to connect signal wires to the control board. Connect only one wire per terminal.

**F - Power Connection (Line 1 and Line 2)** — Power connection to transfer switch.

**G - Neutral and Ground Connection** — Connect to transfer switch neutral and ground

- For power output connection (Line 1, Line 2, Neutral, and Ground), 300V, 6 AWG copper wire, or 300V, 4 AWG aluminum wire, (ref. NEC Table 310.16, 100 ft. Use National Electric Code for correction factors and wire size calculations).
- For utility circuit connection (Utility A and Utility B) use #14 AWG minimum copper 300 volt 90°C wire or 300V, 4 AWG aluminum wire.
- For transfer switch communication use #18 AWG twisted pair conductors, no greater than 200 ft in length, 300 volt 90°C wire.
- When connecting to the terminal block, fasten only one wire to each connector screw.
- Torque terminal block screws to 4.4 in-lb (0.49 Newton meter).
- Torque circuit breaker connections to 45 in-lb (5 Newton meter).

## Generator AC Connection System

A single-phase, three-wire AC connection system is used in the home generator. The stator assembly consists of a pair of stationary windings with two leads brought out of each winding. The junction of leads 22 and 33 forms the neutral lead, as shown schematically and as a wiring diagram. A complete schematic and wiring diagram can be found later in this manual.

**NOTICE** Neutral is not bonded to ground at generator.

**NOTICE** Generator must be used with only an UL approved transfer switch that is compatible with the generator.

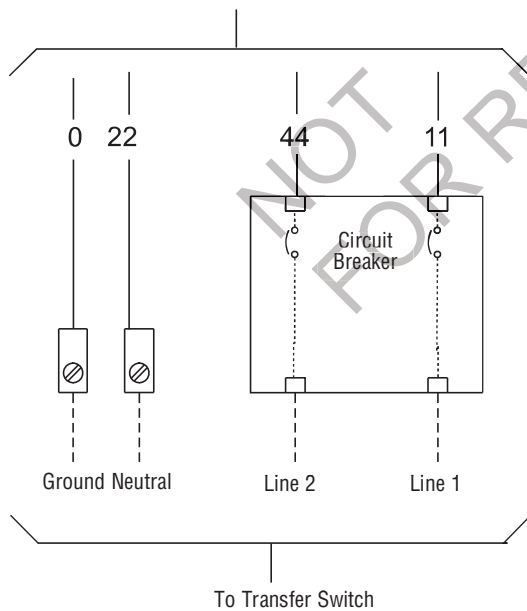
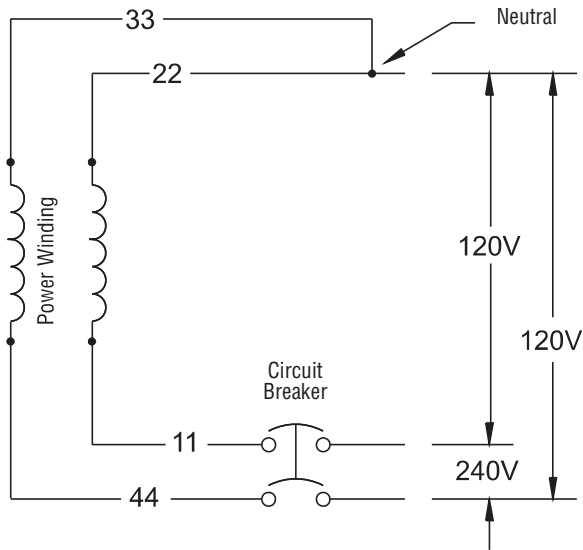



## Grounding the Generator

The home generator must be installed as part of a system that includes a listed transfer switch, with neutral to ground bonding at the transfer switch in accordance with installation instructions. Unless mandated by local code, additional grounding to earth at the generator is not required. Any grounding at generator must use metal piercing lock washers (or equal), UL listed terminals installed per terminal supplier's instructions, and comply with national electrical codes and local requirements.

## Utility Circuit Connection

"240V Utility" leads must be routed in conduit. The "240V Utility" leads deliver power to the generator's circuit board, optional battery warmer and optional oil warmer. This power also charges the battery. When power on these leads is lost, the generator will start.

Using installer-supplied minimum 300V, 6 AWG copper wire, or 300V, 4 AWG aluminum wire\*, connect each control circuit terminal in the generator (Utility A and Utility B) to the fuse block in the automatic transfer switch.

*\*Use National Electric Code for correction factors and wire size calculations.*

## Generator Power Connection

Using installer supplied minimum 300V, 6 AWG wire, connect generator power output Line 1, Line 2, neutral and ground to the corresponding Line 1, Line 2, neutral and ground in the transfer switch.

## Transfer Switch Communication

Using installer supplied #18 AWG twisted pair conductors, no greater than 200 ft in length, connect Tx Rx and Tx Rx GND from the generator terminal block to T/R and GND on the transfer switch control board. When making connections, obey wire type and torque specifications printed on the circuit breaker and neutral/ground connectors.

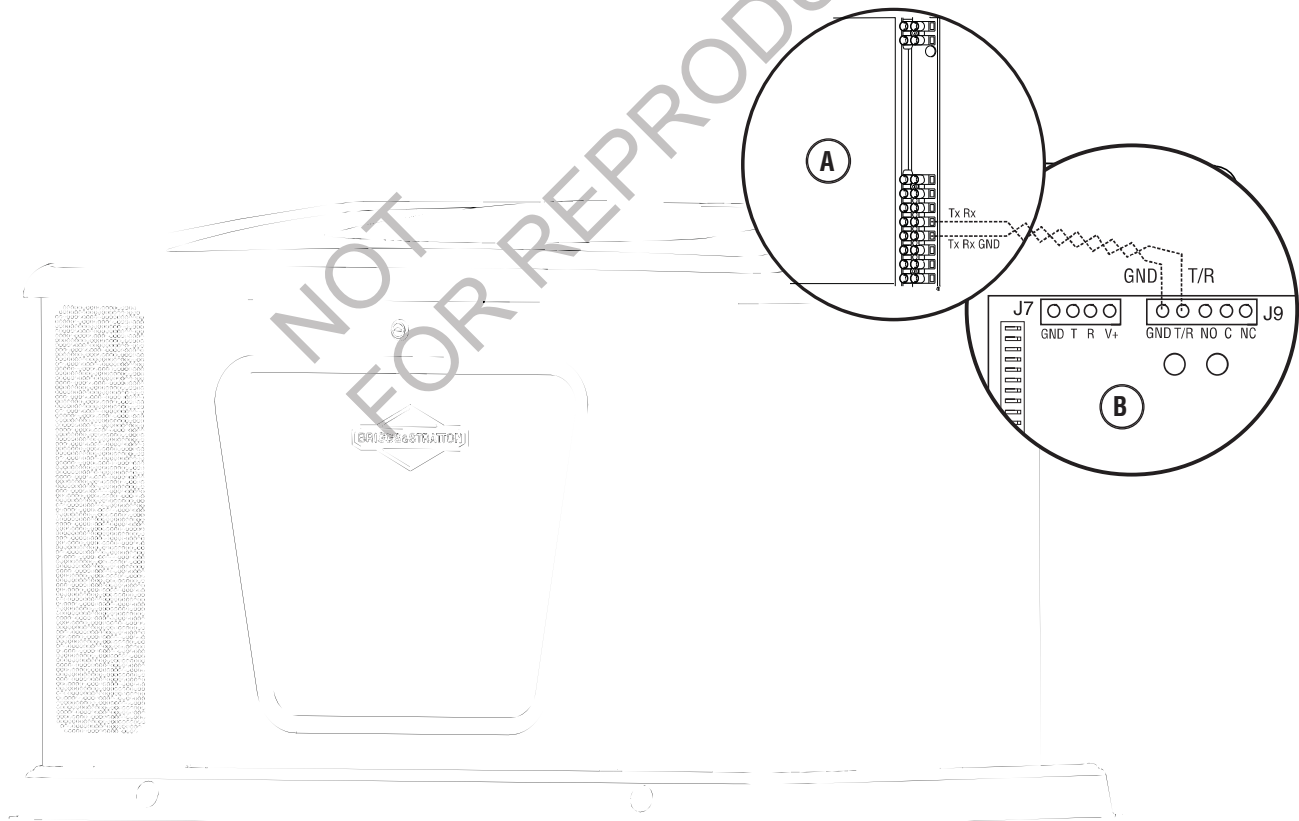

## System Control Panel

The generator control panel, located inside the generator housing, is shown below.

Brief descriptions of the controls used during installation are:

The generator control board, located inside the generator, under the roof, is shown below. Brief descriptions of the controls used during installation are:

**A - Menu/Programming Navigation Buttons** — See Menu section for details

**B - Mini USB Port** — Authorized Dealer Service Use Only

**C - Generator Operation Control Buttons** —

- “**AUTO**” Normal operating position. Press and hold button to put unit into Automatic mode. If an utility power outage is sensed, the system will start the generator. When utility power is restored, auto lets the engine stabilize internal temperatures, shuts off the generator, and waits for the next utility outage.

- “**OFF**” Turns off running generator, prevents unit from starting, and resets any detected faults.

OFF must be pressed and held for more than 5 seconds in order to reset service codes.

- “**MANUAL**” Used to manually start the generator.

“**AUTO**” **LED** — LED will light when unit is placed into Auto mode. LED will blink if exercise cycle is not set or set to OFF.

**D - 15 Amp Fuse** — Protects the home generator DC control circuits. If the fuse has ‘blown’ (melted open) or was removed, the engine cannot crank or start. Replace the fuse using only an identical ATO 15A fuse. One spare fuse is supplied with the unit.

**E - Cover** — This protective cover must be opened to access the fuse and the USB port.





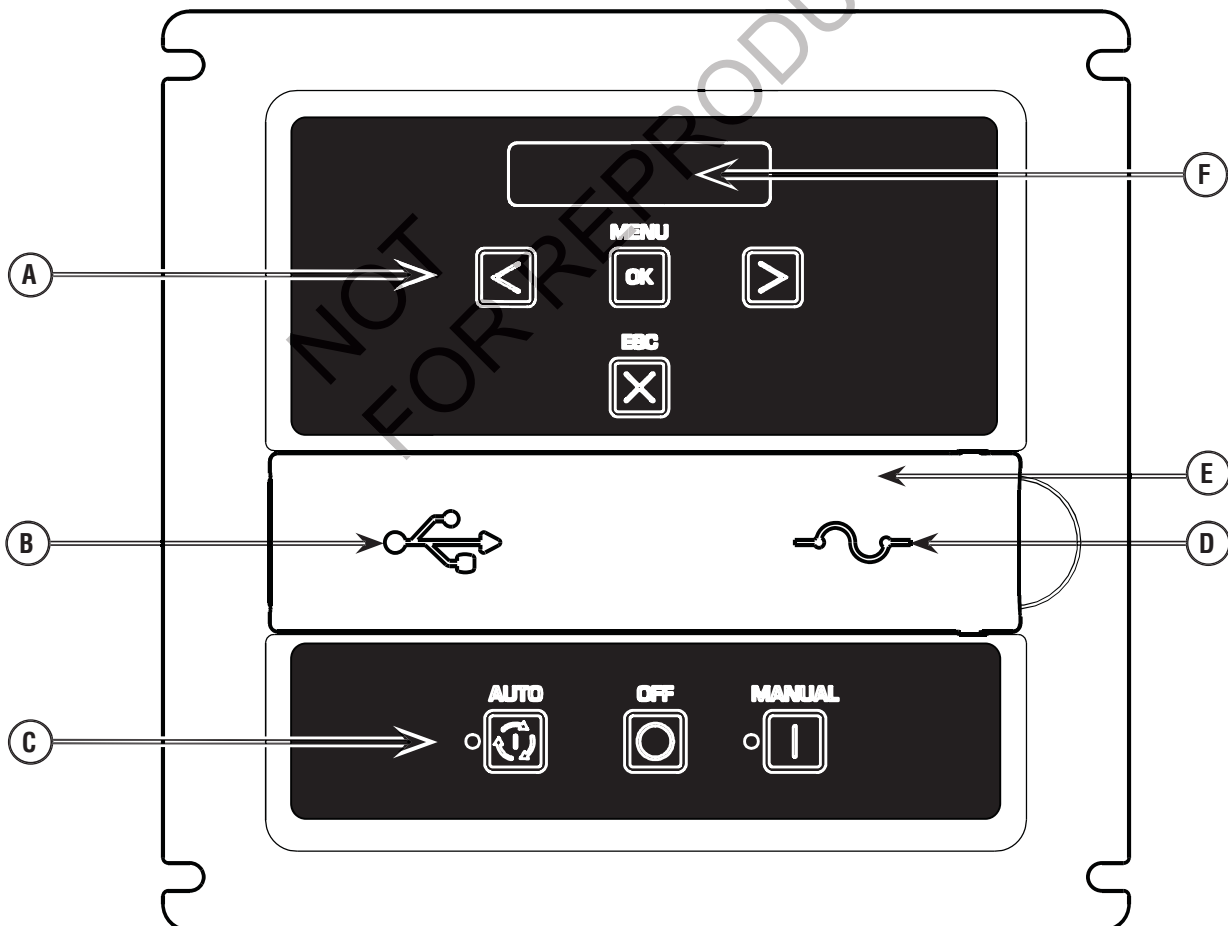

**F - Digital Display** — Displays generator mode, menu options, service codes, and service engine indicators

More information may be found in Controls in the operator’s manual.









## Menu

The following chart shows the icons for the buttons that control the system control panel.

	<b>MENU</b>	ENTER THE MENU (VIEW SETTINGS) PRESS TO CONFIRM SELECTION WHEN PROGRAMMING.
	<b>ESCAPE (EXIT)</b>	RETURN TO LAST MENU ITEM
	<b>RIGHT ARROW</b>	TOGGLE THROUGH MENU OPTIONS SETTING SYSTEM PARAMETERS
	<b>LEFT ARROW</b>	TOGGLE THROUGH MENU OPTIONS SETTING SYSTEM PARAMETERS
	<b>MANUAL MODE</b>	USED TO MANUALLY START THE GENERATOR. PRESS AND HOLD BUTTON TO START THE GENERATOR.
	<b>OFF</b>	TURNS OFF RUNNING GENERATOR, PREVENTS UNIT FROM STARTING, AND RESETS ANY DETECTED FAULTS.
	<b>AUTOMATIC MODE</b>	NORMAL OPERATING POSITION. PRESS AND HOLD BUTTON TO PUT UNIT INTO AUTOMATIC MODE. IF A UTILITY POWER OUTAGE IS SENSED, THE SYSTEM WILL START THE GENERATOR. WHEN UTILITY POWER IS RESTORED, AUTO LETS THE ENGINE STABILIZE INTERNAL TEMPERATURES, SHUTS OFF THE GENERATOR, AND WAITS FOR THE NEXT UTILITY POWER OUTAGE.

The following chart describes key sequences for accessing different programming modes;

 	<b>GENERAL SET-UP</b>	PRESS AND HOLD <b>[ARROW LEFT AND ARROW RIGHT]</b> FOR THREE SECONDS TO ENTER THE PROGRAM MODE.
  	<b>ADVANCED SETTINGS</b>	PRESS AND HOLD <b>[ARROW LEFT, ARROW RIGHT AND ESC]</b> FOR THREE SECONDS TO ENTER THE ADVANCED SETTINGS MODE.
 	<b>WIRELESS LINK MODE</b>	PRESS AND HOLD <b>[MENU AND ESC]</b> FOR THREE SECONDS TO ENTER THE WIRELESS LINKING MODE.

## General Set Up Screen

For general set up, press and hold the left arrow and right arrow   for 3 seconds. Follow the prompts as outlined below.

NOTE: Date and Time were set at the factory and stored in the control panel memory. The Exercise Cycle was also set at the factory. The default exercise cycle occurs on Tuesdays, at 2:00 P.M. Central Standard Time. To updated or change these settings, follow the steps below.

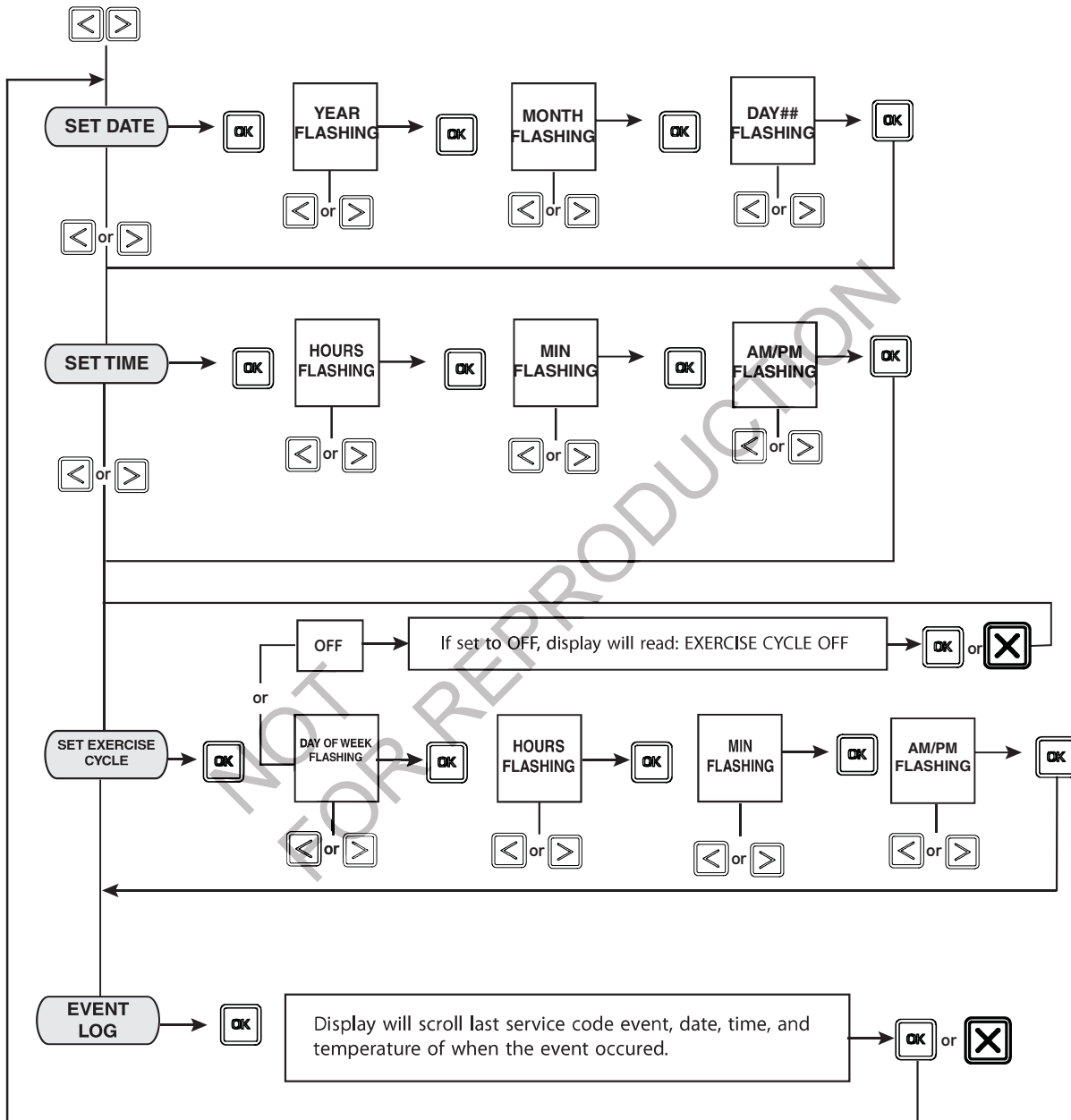

IF DURING PROGRAMMING NO BUTTONS ARE PRESSED FOR 30 SECONDS, THE CONTROL PANEL WILL AUTOMATICALLY EXIT THE PROGRAM MODE.

## Control Panel Prompts

### Automatic Mode

In Automatic Mode, the display screen will display via scrolling text:

- GENERATOR READY - if the unit is in standby and utility power is present.
- GENERATOR ON - if the unit is running and utility power is not present.
- SERVICE CODE - if a system fault has been detected.

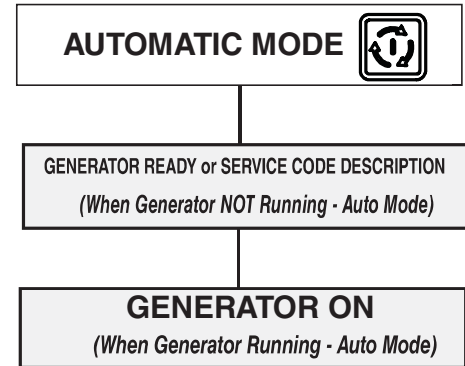

### General System Parameters

To view general system parameters, press the MENU button.

The following will scroll across the digital display and then move to the next item:

- Run time
- Date
- Time
- Exercise Cycle date and start time

The user can press the LEFT ARROW or RIGHT ARROW at any time to move to the next item.

The user can press ESCAPE to go back to GENERATOR READY.

If no user inputs are made for 10 seconds after all the items have been displayed, the control board will reset to GENERATOR READY.

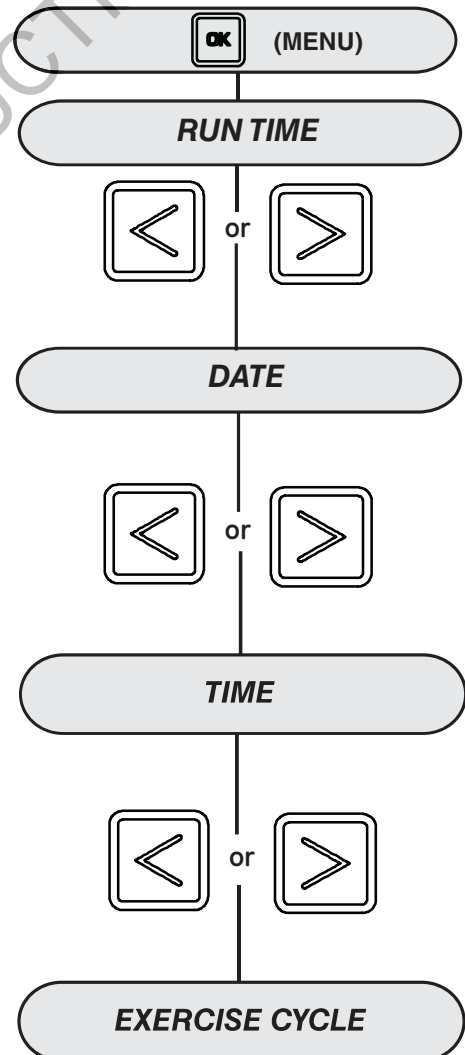



## Advanced Settings Screen

Advanced setting parameters are preset at the factory for a typical installation. To view Advanced Settings items and/or to change items, follow the instructions listed below.

**NOTICE** Advanced settings are critical to the operation of the unit. Careful consideration should be taken when working in the Advanced Settings menu. Exercise caution when selecting and verifying parameters for the generator and region where the generator is being operated. Confirm all settings before operating the generator for the first time.

For advanced menu items, press and hold the left arrow, right arrow, and escape key    for 3 seconds. Follow the prompts as outlined below.

**NOTICE** In the Advanced Setting menu, a three button access code (left arrow, right arrow, and escape key   ) must be pressed once to enter the menu and again to change any setting. After each confirmation of a setting, the selection will display solid for 2 seconds before moving to the next program item.

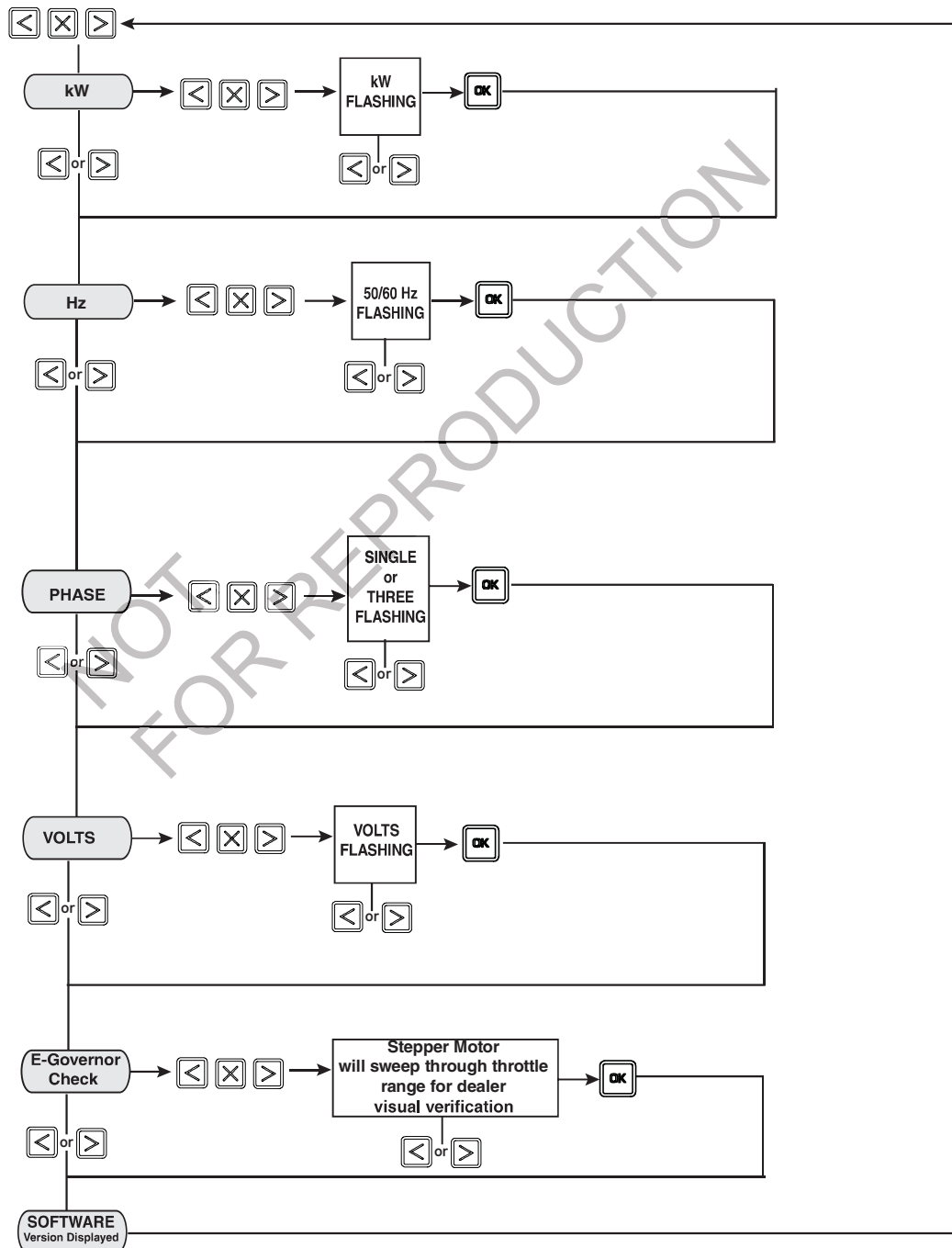

## Service Code Detection System

The generator may have to run for long periods of time with no operator present. For that reason, the system is equipped with sensors that automatically shut down the generator in the event of potentially damaging conditions, such as low oil pressure, high temperature, over speed, and other conditions. Refer to *Service Code Detection System* in the operator's manual for more detailed information.

## Final Installation Considerations

### Engine Oil

**NOTICE** Any attempt to crank or start the engine before it has been properly serviced with the recommended oil will result in equipment failure.

- Refer to Maintenance in the operator's manual for oil fill information.
- Damage to equipment resulting from failure to follow this instruction will void engine and generator warranty.

The engine is shipped from the factory pre-run and filled with synthetic oil (API SJ/CF 5W-30). This allows for system operation in a wide range of temperature and climate conditions. Before starting the engine, check oil level and ensure that engine is serviced as described in Maintenance of the Operator's Manual.

The use of synthetic oil **does not** alter the required oil change intervals described in the Operator's Manual.

For operation of temperatures below 30°F (-1°C), the use of fully synthetic oil (minimum API SJ) of viscosity 5W30 is required.

## Battery

**▲ WARNING** Battery posts, terminals and related accessories contain lead and lead compounds, chemicals known to the State of California to cause cancer and reproductive harm. Wash hands after handling.

The installer must supply and install rechargeable starting battery. The starting battery **MUST** conform to the specifications shown below in the chart.

Battery Specifications	Standard	Cold Start (less than 30°F)
Volts	12 Volt DC	12 Volt DC
Amps (MIN)	540 CCA (cold cranking amps)	630 CCA (cold cranking amps)
Construction	Wet lead acid	Wet lead acid
Terminal Type	Top post type battery	Top post type battery
Dimensions (MAX):	BCI size 26	BCI size 75

Install the battery as described in *Servicing the Battery* in the *Maintenance* section of the Operator's Manual. Always make sure the **NEGATIVE** cable is connected last.

**▲ WARNING** Storage batteries give off explosive hydrogen gas during recharging. Slightest spark will ignite hydrogen and cause explosion, resulting in death, serious injury and/or property damage.



Battery electrolyte fluid contains acid and is extremely caustic. Contact with battery contents could cause severe chemical burns. A battery presents a risk of electrical shock and high short circuit current.

- DO NOT dispose of battery in a fire. Recycle battery.
- DO NOT allow any open flame, spark, heat, or lit cigarette during and for several minutes after charging a battery.
- DO NOT open or mutilate the battery.
- Wear protective goggles, rubber apron, rubber boots and rubber gloves.
- Remove watches, rings, or other metal objects.
- Use tools having insulated handles.

## Initial Start-up (No Load)

The unit has been set-up for NG operation at the factory. Fuel conversion, if needed, must be completed prior to performing these steps. See *Fuel Conversion*.

Before operating the home generator or placing it into service, inspect the entire installation carefully. Then begin testing the system without any electrical loads connected, as follows:

1. Remove three screws (**A**) that secure control box cover to enclosure to expose unit's circuit breaker.
2. Connect an accurate frequency meter to line side of generator's main circuit breaker.
3. Set generator's main circuit breaker to **ON** (closed) position.
4. Install 15 Amp fuse in control board.
5. Press and hold **MANUAL** button on control board for 3 seconds. Engine will start.
6. Listen for unusual noises, vibration or other indications of abnormal operation. Check for oil leaks while engine runs.
7. Let engine warm up for about 5 minutes to allow internal temperatures to stabilize.
8. Check generator output at load side of circuit breaker. Voltage should be 225 - 250 Volts, frequency should be 59.0 - 61.0 Hz.
9. Check generator output between one generator connection lug and neutral lug, then between other generator connection lug and neutral lug. In both cases, voltage reading should be between 112 and 125 Volts.
10. Push and hold **OFF BUTTON** on control board until engine stops.
11. Reinstall control box cover.

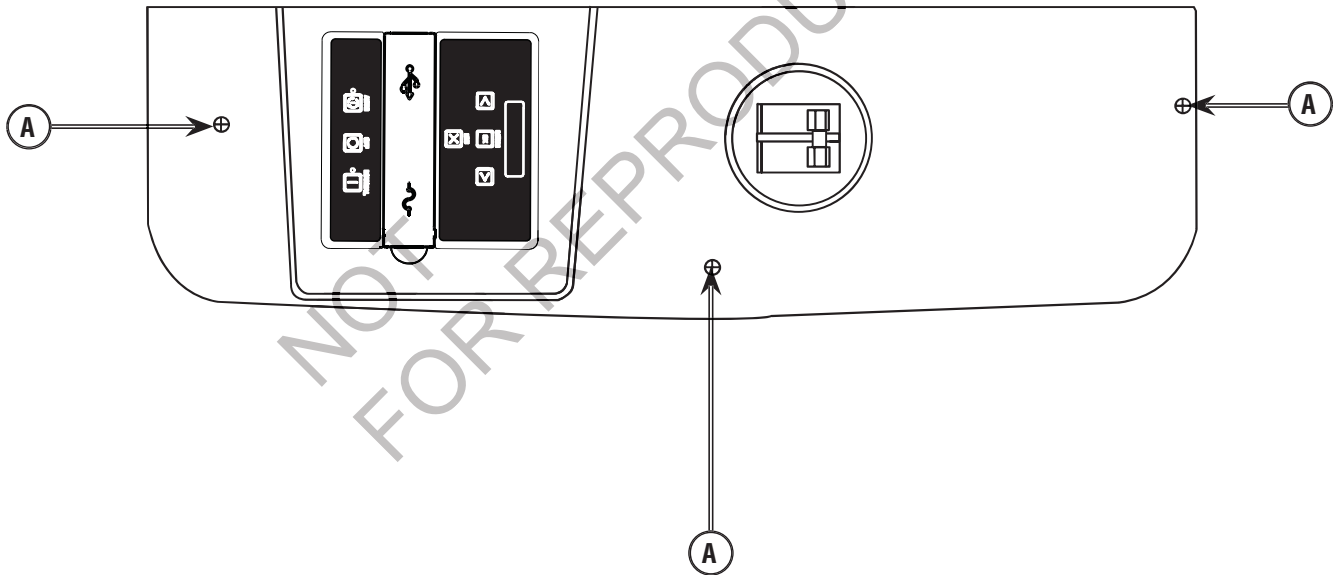



## Electronic Governor System

The engine electronic governor system allows for improved control and increased generator performance compared to mechanically governed systems. The result is smooth steady-state operation without the “hunting” common to many mechanical governors. The system also reduces speed variations under engine loading and unloading and significantly reduces frequency fluctuation experienced when the engine is under higher loads.

The electronic governor system is composed of a stepper motor (**B**), stepper motor throttle control linkages (**C**), and throttle side linkage (**A**). The control board contains a digital controller that processes engine speed information and sends appropriate commands to the stepper motor to control the position of the engine throttle.

Since the electronic governing system controls the engine throttle demand based upon generator load, the following service codes and/or conditions may be related to an electronic governing system issue:

- Engine Does Not Start
- Over Speed
- Under Frequency
- Unstable No Load Engine Control

While trouble shooting any of these conditions, a verification of the electronic governor system can be initiated through the control panel – advanced menu options – Electronic Governor Check.

### Electronic Governing Check:

The generator has an electronic governing check feature that will turn on the stepper motor and move the throttle linkage clockwise and counterclockwise within the throttle limits. The test will rotate the stepper motor and move the throttle arm between the wide open throttle and dead idle limits 4 times with a 2 second delay between each throttle sweep. This will allow visual verification that the stepper motor is functioning properly and the control linkages are connected. The engine will not attempt to start during this test. If the stepper motor does not move, or if a linkage binds, then service may be required.

**NOTICE** If stepper motor does not move, please make sure the stepper motor connector is attached.

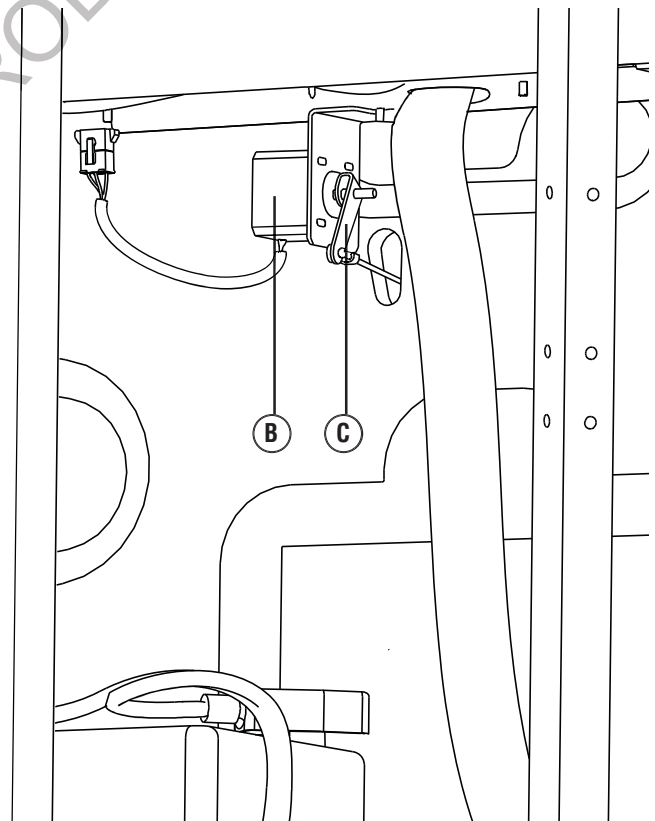
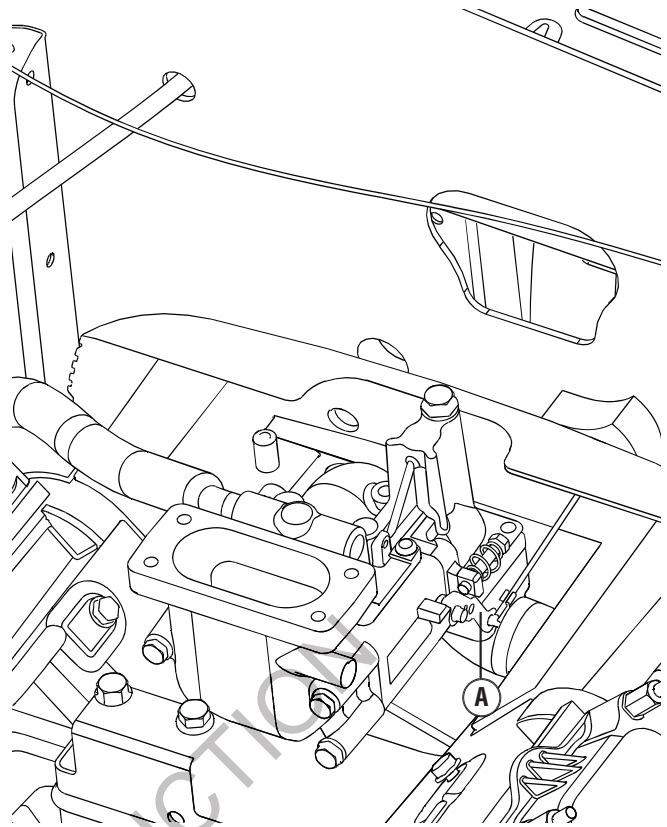

# Operation

## Automatic Operation Sequence

The generator's control board constantly monitors utility voltage. Should utility voltage drop below a preset level, the control board will signal the engine to crank and start.

When utility voltage is restored above a preset voltage level, the engine is signaled to shut down.

The actual system operation is not adjustable and is sequenced by sensors and timers on the control board, as follows:

### Utility Voltage Dropout Sensor

- This sensor monitors utility source voltage.
- If utility source voltage drops below about 70 percent of the nominal supply voltage, the sensor energizes a 3 second timer. The timer is used to 'sense' brown-outs.
- Once the timer has expired, the engine will crank and start.

### Utility Voltage Pickup Sensor

This sensor monitors utility power voltage. When utility voltage is restored above 80 percent of the nominal source voltage, a time delay starts timing and the engine will go to engine cool-down.

### Engine Cool-down Timer

When utility power is sensed and the load transfers to the utility source, the engine will go into a cool down period as described below:

- If the generator has run for MORE than 5 minutes, once the utility transfer occurs, the engine will continue to run for about 1 minute before shutting down.
- If the generator has run for LESS than 5 minutes, once the utility transfer occurs, the engine will continue to run until 5 minutes has elapsed before shutting down.

## Setting Exercise Timer

The generator is equipped with an exercise timer. During the exercise period, the unit runs for approximately 20 minutes and then shuts down. Electrical load transfer DOES NOT occur during the exercise cycle (unless an utility power outage occurs).

The generator will only enter the exercise cycle if the unit is in the AUTO mode and this exact procedure is followed.

### To set the exercise timer:

**NOTICE** The generator is set with a default exercise cycle setting of Tuesday at 2:00 P.M, Central Time. To change the cycle setting, proceed to the following steps:

1. Choose the day and time you want your generator to exercise.
2. Press and hold the left arrow and right arrow simultaneously for 3 seconds to enter the General Set-Up program mode. See General Set-Up flow chart in Menu Section.
3. Verify and/or set the time and date on the unit.
4. Go to the SET EXERCISE prompt and hit the "OK" button.

**NOTICE** Items will flash until they are selected.

SELECT DAY: Use the left or right arrow to toggle through the days of the week, Once the day is selected, hit the "OK" button.

SELECT HOUR: Use the left or right arrow to toggle through between 1 and 12. Choose the hour of day you want the generator to exercise then hit the "OK" button.

SELECT MINUTE: Use the left of right arrow to toggle between :00 and :59. Choose the minute of the day you want the generator to exercise then hit the "OK" button.

SELECT AM/PM: Use the left of right arrow to toggle between AM and PM. Once chosen, hit the "OK" button.

**NOTICE** During the weekly exercise cycle, the generator will run for 20 minutes, but it will not supply power to the home. During the exercise cycle, the in-home monitor will continue blinking the GENERATOR READY green LED.

If you want to change the day and time the unit exercises, simply perform the procedure again.

To turn off the generator exercise cycle, go to the OFF selection within the day of the week menu and press OK. The display will then scroll: EXERCISE CYCLE OFF.

## Installation Inspection

Before placing the generator system into service, inspect the entire installation carefully.

This completes the installation and start-up instructions. The operator's manual provides full details on Operation, Maintenance and Troubleshooting for this generator system.

# Schematic / Wiring Diagrams

## Schematic Diagram

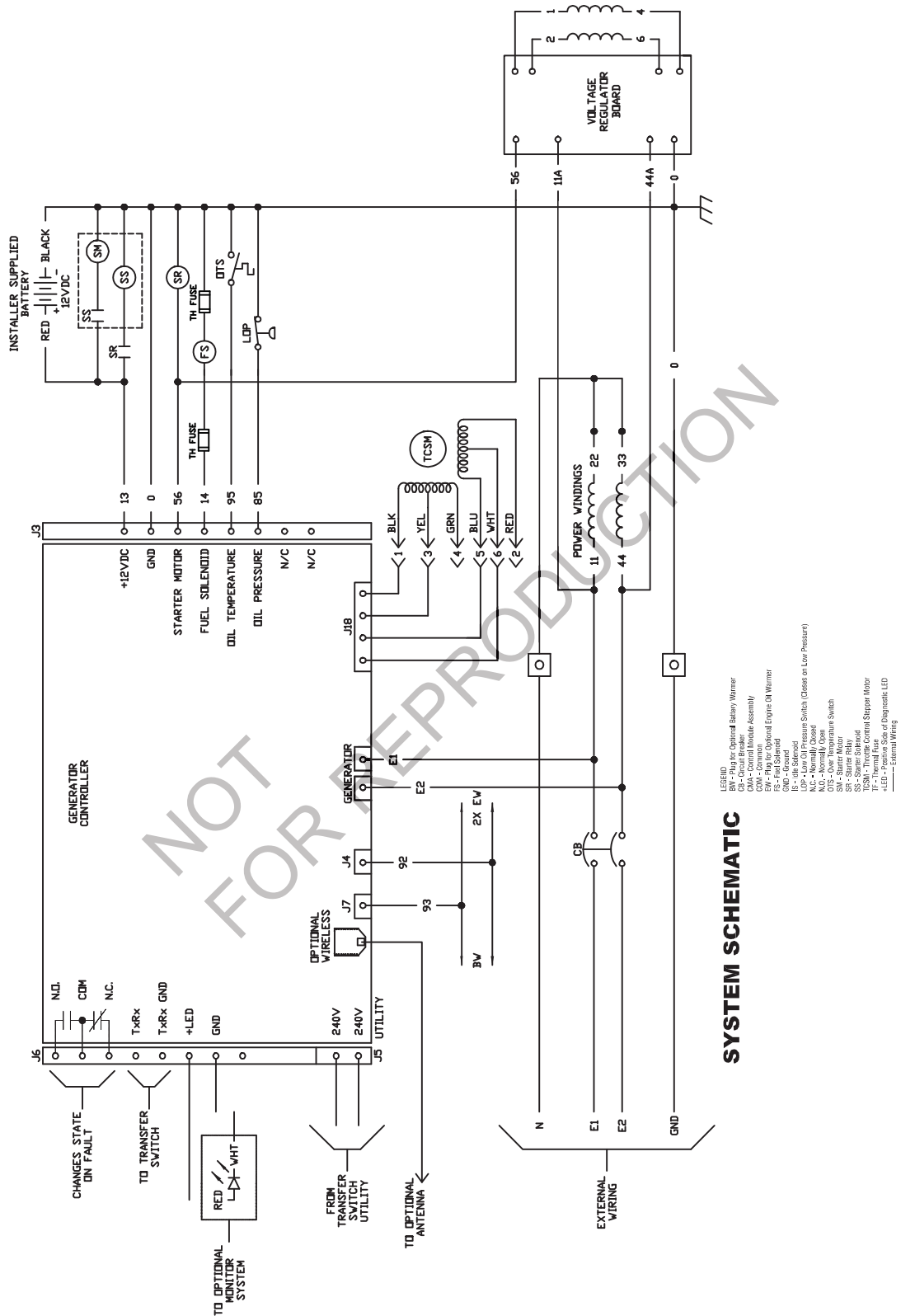

# Wiring Diagram

